

City of North Port



REQUEST FOR BID NO.2023-23

HURRICANE IAN PERMANENT REPAIRS FOR FIXED WEIR (FW) NO. 123 EROSION REPAIRS



NOTICE OF AVAILABILITY OF BID SPECIFICATIONS

**RFB NO. 2023-23
HURRICANE IAN PERMANENT REPAIRS FOR
FIXED WEIR (FW) NO. 123 EROSION REPAIRS**

The City of North Port will be requesting sealed bids from a licensed and experienced Contractor capable of performing permanent repairs to City's infrastructure due to Hurricane Ian. The work may include, but is not limited to, structural and drainage constructions services as described within this bid document.

FEDERAL FUNDING: The projects, programs, and activities to be funded under this Agreement are fully or partially funded by Federal funding, grants and disaster assistance from various federal and state agencies including the Florida Division of Emergency Management (FDEM) and the Federal Emergency Management Agency (FEMA).

NON-MANDATORY PRE-BID MEETING: MARCH 3, 2023, AT 10:00 AM

4970 CITY HALL BOULEVARD, CITY MANAGER, 3RD FLOOR, ROOM 302, NORTH PORT, FLORIDA 34286

All potential Bidders are recommended but not required, to attend the non-mandatory pre-bid conference which will be conducted to discuss contractor requirements and to answer questions regarding the bid requirements. The purpose of the Pre-Bid Meeting is to provide a briefing on the City's expectations and performance requirements for submission of Bid documents.

BID OPENING: MARCH 20, 2023, AT 2:00 PM

4970 CITY HALL BOULEVARD, ROOM 337A, NORTH PORT, FLORIDA 34286

****ALL BIDS ARE DATE AND TIME STAMPED IN THE FINANCE DEPARTMENT, SUITE 337 FIRST AND THEN ARE OPENED IN SUITE 337A****

Information regarding this project may be viewed and downloaded from Demandstar's website at www.demandstar.com. The only place to obtain the addenda is on www.demandstar.com. Links to DemandStar are also available from the City website at www.northportfl.gov. Bid specifications, attachments/exhibits are posted on the City FTP site at <https://www.northportfl.gov/filesshare> (**select the Purchasing Folder and scroll to Project RFB 2023-23**). If you have any questions, concerns, or problems accessing the bid package using the link, please contact Alla V. Skipper, CPPB, Senior Contract Administrator at 941.429.7172. Requests for additional information or clarification regarding the specifications must be sent via email to purchasing@northportfl.gov. No verbal requests will be honored. All questions and clarifications must be submitted via e-mail by **March 13, 2023, by 2:00PM**.

The City of North Port does not discriminate on the basis of race, color, national origin, sex, age, disability, family or religious status in administration of its programs, activities or services.

PUBLISH DATES: February 16, 2023

- Sarasota Herald Tribune
- www.northportfl.gov & www.demandstar.com

NOTIFICATION DATES: February 16, 2023

- Minority Business Development Agency of Department of Commerce: Miami & Orlando <https://www.mbda.gov/>
- Department of Labor – Labor Surplus Areas and Veteran Affairs <https://www.dol.gov/>
- Florida State -Minority Supplier Development Counsel <https://fmsdc.org/>
- <https://www.sba.gov/>

TABLE OF CONTENTS

<u>TITLE</u>	<u>PAGE NUMBERS</u>
NOTICE OF AVAILABILITY OF BID SPECIFICATIONS (LEGAL NOTICE)	2
TABLE CONTENTS	3
STATEMENT OF NON-SUBMITTAL	4
SECTION I: INSTRUCTION TO BIDDERS	5
SECTION II: GENERAL PROVISION	18
SECTION III: SPECIAL AND TECHNICAL SPECIFICATIONS	31
SECTION IV: TECHNICAL SPECIFICATIONS	
SECTION V: CHECK LIST: CITY FORMS (ATTACHMENTS A-I) CHECK LIST: FEDERAL PROVISIONS AND SUPPLEMENTAL (ATTACHMENTS 1-18)	44

****TO BE COMPLETED AND RETURNED WITH BID****

SECTION VI: SAMPLE CONTRACT

- "THIS IS A 'SAMPLE CONTRACT' ISSUED FOR INFORMATIONAL PURPOSES ONLY AND AS SUCH IS SUBJECT TO CHANGE"

EXHIBITS

1. MAP OF FW NO. 123 LOCATION
2. CONTRACT DRAWINGS (4 PAGES)
3. **ATTACHMENT C** - BID SCHEDULE (1 PAGE, EXCEL FORMAT)

STATEMENT OF NON-SUBMITTAL

If you **do not** intend to submit a bid on this service, please return this form (see information below) immediately.

We, the undersigned, have declined to submit a bid on the requested Request for Bid NO. **2023-23 Hurricane Ian Permanent Repairs for Fixed Weir (FW) no. 123 Erosion Repairs**

_____ Insufficient time to respond to the Request for Bid.

_____ We do not offer this product/service.

_____ Our schedule would not permit us to perform.

_____ Unable to meet bond/insurance requirements.

_____ Specifications are unclear (explain below).

_____ OTHER (please specify below).

REMARKS: _____

COMPANY NAME: _____

ADDRESS: _____

CITY: _____ **STATE:** _____ **ZIP CODE:** _____

TELEPHONE: _____ **FAX:** _____

E-MAIL ADDRESS: _____

PRINT NAME AND TITLE: _____

DATE: _____

Note: "Statement of No Bid" may be faxed or e-mailed to the Purchasing Division at purchasing@northportfl.gov.

SECTION I. INSTRUCTIONS TO BIDDERS

THESE CONDITIONS ARE STANDARD FOR ALL BIDS FOR COMMODITIES/SERVICES ISSUED BY THE CITY OF NORTH PORT. THE CITY OF NORTH PORT MAY DELETE, SUPERSEDE OR MODIFY ANY OF THESE GENERAL CONDITIONS FOR A PARTICULAR CONTRACT BY INDICATING SUCH CHANGE IN SPECIAL CONDITIONS TO BIDDERS OR IN THE BID SHEETS. ANY AND ALL SPECIAL CONDITIONS THAT MAY VARY FROM THE GENERAL CONDITIONS SHALL HAVE PRECEDENCE. BIDDER AGREES THAT THE PROVISIONS INCLUDED WITH THIS REQUEST FOR BID SHALL PREVAIL OVER ANY CONFLICTING PROVISIONS WITHIN ANY STANDARD FORM CONTRACT OF THE BIDDER REGARDLESS OF ANY LANGUAGE IN BIDDER'S CONTRACT TO THE CONTRARY.

DEFINITIONS: Terms used in these Instructions to Bidders are defined and have the meanings assigned to them.

- **Addenda:** a written change to a solicitation
- **Bid:** any offer submitted in response to this request for Bid.
- **Bidder:** One that submits a bid in response to this Request for Bid.
- **Bid Documents:** Includes the General Terms and Conditions: Special Conditions: Technical Specifications, the Bid Form: Non-Collusive Affidavit: Public Entity Crime Form: Certificate(s) of Insurance, if required: Payment and Performance Bonds, if required: Corporate Resolution: Bid Bond, if required: Scrutinized Company Affidavit and Certification and all Addendums issued prior to receipt of bids.
- **City:** Shall refer to City of North Port, a municipal corporation of the State of Florida.
- **Contract:** The agreement to perform the services set forth in this solicitation. The Contract will be comprised of the Bid documents signed by both parties including any addenda and other attachments specifically incorporated.
- **Responsible:** Refers to a Bidder that has the capacity and capability to perform the work required under a Request for Bid and is otherwise eligible for award.
- **Responsive:** Refers to a bid that contains no exceptions or deviations from the terms, conditions, and specifications set forth in the Request for Bid.
- **Request for Bid (RFB):** Shall mean this solicitation document, including any and all addenda. A RFB contains well-defined terms, conditions, and specifications, and is awarded to the lowest priced responsive and responsible Bidder.
- **Solicitation:** The written document requesting either bids or proposals from the marketplace.
- **Successful Bidder(s):** The lowest responsive, responsible Bidder(s) to whom City (on basis of City's evaluation) makes an award.
- **Vendor or Contractor:** A general reference to any entity responding to this solicitation or performing under any resulting Contract.

The City has established for purposes of this Request for Bid (RFB) that the words "shall," "must," or "will" are equivalent and indicate a mandatory requirement or condition, the material deviation from which shall not be waived by the City. A deviation is material if, in the City's sole discretion, the deficient response does not substantially satisfy this RFB's mandatory requirements. The words "should" or "may" are equivalent in this RFB and indicate very desirable conditions, or requirements that are permissive in nature.

1. INSTRUCTIONS TO BIDDERS

A. QUALIFICATIONS OF BIDDER: It is intent to the City to award this Contract to the lowest responsible Bidder, qualified by experience and solvency, with proven reliability and the ability to provide the services or items required under this Contract within a reasonable time frame acceptable to the City. Bidder may be required to supply information in writing at the request and discretion of the City prior to award of bids, in order to verify above requirements.

B. EXAMINATION OF BID DOCUMENTS: Prior to submission of a bid form, Bidders shall carefully examine the General Terms and Conditions, Special Conditions, Technical Specifications, and all other related bid documents, including all modifications thereof, incorporated in the bid package, plus fully informing themselves as to all existing conditions and limitations that effect the work to be performed under this Contract.

Discrepancies, omissions, or questions about the intent of the documents should be submitted to the Purchasing Division in written form as a request for interpretation no later than five business (5) days prior to bid opening (or shall be verbally addressed at the pre-bid conference, if applicable).

It shall be the responsibility of the Bidder, prior to submitting their response, to either visit www.demandstar.com to view the solicitation and download all issued addenda or contact Purchasing to determine if addenda were issued.

Examination of site: Prior to submitting a bid form, each Bidder may examine the site and all conditions thereon. All bid forms shall be presumed to include all such existing conditions as may affect any work to be done on this project. Failure to familiarize himself with such conditions will in no way relieve the successful Bidder from the necessity of furnishing any materials or performing any work that may be required to complete the work in accordance with the Specifications.

C. CLARIFICATION AND ADDITIONAL INFORMATION: Discrepancies, omissions, or questions about the intent of the documents will be submitted to the City of North Port Purchasing Manager, or his/her designee in written form as a request for interpretation no later than five (5) business days prior to the bid opening (or may be verbally addressed at the pre-bid meeting, if applicable).

Interpretations made will be in the form of an addendum to the documents, which will be forwarded to all Bidders. Receipt by each Bidder must be acknowledged on the bid form, indicating the addendum number and date of issue, therein becoming part of the Contract. No oral explanations shall be binding. The City will attempt to notify all prospective Bidders of addenda issued to the bid documents: however, it shall be the responsibility of the Bidder, prior to submitting their bid, to contact the Purchasing Manager, or his/her designee, to determine if addenda were issued, acknowledging and incorporating it into their bid.

D. MODIFICATION OR WITHDRAWAL OF BIDS: Bid modifications will be accepted from a Bidder only if received in writing, properly signed by an officer of the Bidder, and received prior to the opening of bids. Bid modifications must be identified as such and will be opened with the Bidder's bid form.

Bids may be withdrawn by request of the Bidder prior to the time fixed for opening. Error or negligence on the part of the Bidder in preparing the bid confers no right for the withdrawal of the bid after it has been opened.

E. NO BID: A respondent who is on the bid notification list and decides not to submit a response is requested to complete the Statement of Non-Submittal Form and return it to the City.

F. CONFLICTS WITHIN SOLICITATION: Where there appears to be a conflict between the General Terms and Conditions, Special Conditions, the Technical Specifications, the Bid Form, or any addendum issued, the order of precedence shall be: the last addendum issued, the Bid Form, the Technical Specifications, the Special Conditions, and then the General Terms and Conditions. It is incumbent upon the vendor to identify such conflicts to the designated purchasing representative prior to the bid or proposal response date.

G. PROMPT PAYMENT: It is the policy of the City that payment for all purchases by the City shall be made in a timely manner and that interest payments will be made on late payments in accordance with Part VII, Chapter 218, Florida Statutes, known as the Local Government Prompt Payment Act. The Bidder may offer cash discounts for prompt payments: however, such discounts will not be considered in determining the lowest price during bid evaluation.

2. PREPARATION AND SUBMISSION OF BID FORM

Bid Form: Bids shall be made on forms supplied by the City, or as otherwise specified. Each bid must state the name of the Bidder, the Bidder's full business address and state the type of business entity, followed by the original signature and designation of the officer or other person authorized to bind the corporation. Any erasures or other corrections in the bid form must be explained or noted over the signature of the Bidder. Bid forms containing any conditions, omissions, unexplained erasures, alterations, or irregularities of any kind may be rejected by the City.

Bid Bond: Each bid must be accompanied by a Bidder's bond or Cashier's check with their bid in the amount of NOT LESS THAN 5% of their total amount of the bid. This security shall ensure that the Bidder does not revoke the bid after bid opening or fails to execute any necessary additional documents. Cashier's checks will be returned to all Bidders after award of bid. If using a bid bond use the City of North Port bid bond form.

Bid Documents: Bid documents and forms shall be submitted sealed to the City of North Port, Purchasing, 4970 City Hall Boulevard, Suite 337, North Port, Florida 34286. The envelope/package shall be clearly marked with the Bid Number, Name and Business Address of the Bidder. All interested firms are required to submit one (1) original and one (1) copy of their completed bid offer.

Submission of a response constitutes a binding offer and shall be subject to all terms and conditions specified in the solicitation.

For your bid to be acceptable, **all blank spaces** must be completely annotated where and when requested. All bids must contain a manual signature of the authorized representative of the Bidder in the space provided on the Bid Certification Form.

Responsibility for getting this bid to the City on or before the specified date and time is solely and strictly the responsibility of the Bidder. The City will not be responsible for any delay, for any reason whatsoever. Bids must be received and stamped with the date and time on the outside of the envelope and must be in the City Purchasing Office by the date and time specified for opening.

Bids postmarked prior to said date and time but not received shall not be considered and will be returned to Bidder unopened.

Bid Guarantee: The bid form shall be signed where indicated constituting an agreement that the Bidder will not withdraw his/her bid for a period of ninety (90) days after the opening of the bids.

Source of Supply and Subcontractors: Bidders are to complete the attached Source of Supply and subcontractors form. This form must be completed and included with the bid form. If Bidder does not have a source of supply or subcontractor, insert "to be determined". When source or subcontractor is determined, selection will be subject to City approval.

Bid Opening: All bids received by the date and time so specified shall be opened and **the name of each Bidder and total bid price of each Bidder** read aloud within the designated room at City Hall, at the bid opening. The opening and reading shall be in the presence of the City Clerk and the Purchasing Manager or their designees. Bidders and the general public are not required to be present but are invited to attend.

Late Bids: Bids received after the date and time of bid opening will not be considered and will not be opened. It will be the Bidder's responsibility to make arrangements for the return of the bid package at their expense.

3. CITY RIGHTS: The City of North Port reserves the right to accept or reject any and/or all bids in whole or in part, to waive irregularities and technicalities, and to request resubmission with or without cause and/or to accept the bid that, in its judgment, will be in the best interest of the City. Also, the City reserves the right to accept all or any part of the bid and to increase or decrease quantities to meet additional or reduced requirement of the City. In the event the City receives only one response: the bid may be either accepted or rejected by the City depending on available competition and the timely needs of the City.

4. AWARD OF BID: The award shall be let to the lowest responsive, responsible Bidder who fulfills all criteria and specifications with consideration to favorable references and whose evaluation by the City indicates that the award will be in the best interest of the City.

5.ERRORS: For the purpose of the initial evaluation of bids, the following will be utilized in resolving arithmetic

discrepancies found on the face of the bidding schedule as submitted by Bidders:
Obviously misplaced decimal points will be corrected.

In case of discrepancy between unit price and extended price, the unit price will govern. Apparent errors in extension will be corrected.

Apparent errors in addition of lump sum and extended prices will be corrected. For the purpose of bid evaluation, the City will proceed on the assumption that the Bidder intends his/her bid be evaluated on the basis of the unit prices, extensions, and totals arrived at by resolution of arithmetic discrepancies as provided above and the bid will be so reflected on the tabulation of bids.

6. BID TABULATIONS: Pursuant to Florida Statute §119.071(1)(b), all bid tabulations shall be posted in the City Hall, 4970 City Hall Boulevard, North Port, Florida and on DemandStar's website at www.demandstar.com within thirty (30) days after bid opening or at such time as the agency provides notice of a decision or intended decision, whichever is earlier.

7. WARRANTY: All warranties express and implied, shall be made available to the City for goods and services covered by this solicitation. All goods furnished shall be fully guaranteed by the vendor against factory and workmanship defects. At no expense to the City, the vendor shall correct any and all apparent and latent defects that may occur within the manufacturer's standard warranty period. The special conditions of the solicitation may supersede the manufacturer's standard warranty.

8. DESCRIPTIVE INFORMATION: Unless otherwise specifically provided in the Technical specifications, all equipment, materials and articles incorporated in the work covered by this Contract are to be new and of the most suitable grade for the purpose intended. Unless otherwise specifically provided in the Technical specifications, reference to any equipment, material, article or patented process, by trade name, make or catalog number, shall be regarded as establishing a standard of quality and shall not be construed as limiting competition. If the Bidder wishes to make a substitution to the specifications, the Bidder shall furnish the City the name of the manufacturer, the model number and other identifying data and information necessary to aid in the City in evaluating the substitution. Such substitution shall be subject to City approval. Substitutions shall be approved only if determined by the City to be equivalent to the specifications. A bid containing substitution is subject to disqualification if the City does not approve the substitution.

9. TAXES/FREIGHT: The bid shall include any freight, handling, delivery, surcharges or other incidental charges. Unless otherwise specified in the solicitation, prices quoted shall be F.O.B. Destination. The City is exempt from the payment of Federal and State taxes, including sales tax. The bid offer shall not include sales tax to be collected from the City. The City's sales tax exemption is not available to vendor for items vendor purchases, regardless of whether these items will be transferred to the City.

In the event the project is declared a sales tax recovery project by the City, the following procedure shall apply:

- (a) The City representative shall make a recommendation to the Division of Procurement Services regarding the materials to be purchased:
- (b) When those materials are purchased by the City, all purchase orders shall be issued directly from Purchasing:
- (c) The City shall take title to those materials directly from the manufacturer/supplier and shall bear the risk of loss or damage to the materials which are delivered directly from the manufacturer/supplier:
- (d) The City shall be invoiced directly for the materials from the manufacturer/supplier and shall pay the invoices directly to the manufacturer/supplier, presenting its sales tax exemption certificate at the time of payment.

The cost of any materials purchased through the sales tax recovery program shall be deducted from the Contract amount and the vendor shall no longer be responsible for providing those materials. A written change order shall be executed.

10. CONTINUATION OF WORK: Any work that commences prior to and will extend beyond the expiration date of the

current Contract period shall, unless terminated by mutual written agreement between the City and the vendor, continue until completion without change to the then current prices, terms and conditions.

11. TERMINATION OF CONTRACT:

Funding in Subsequent Fiscal Years: It is expressly understood by the City and the vendor that funding for any successive fiscal years of the Contract is contingent upon appropriation of monies by the City Commissioners. In the event that funds are not available or appropriated, the City reserves the right to terminate the Contract. The City will be responsible for payment of any outstanding invoices and work completed by the vendor prior to such termination.

Termination With or Without Cause: The City Manager may terminate the work under this Purchase Order with or without cause, in whole or in part, whenever the City Manager determines that termination is in the City's best interest. Any termination must be effective by delivery to the Contractor of a written notice of termination at least **thirty (30) calendar days** before the date of termination, specifying the extent to which performance of the work is terminated and the date upon which the termination becomes effective. Except as otherwise directed, the Contractor must cease all work on the date of receipt of the notice of termination or other date specified in the notice; place no further orders or subcontracts for materials, services, or facilities except as necessary for completion of the portion of the work not terminated; terminate all vendors and subcontracts; and settle all outstanding liabilities and claims. The Contractor must deliver to the City all documents (including but not limited to reports, designs, specifications, and all other data) prepared or obtained by the Contractor in connection with its services. After delivery of the documents, the City must pay the Contractor in full settlement of all claims by it hereunder as the work actually completed bears to the entire work under this Purchase Order, as determined by the City, less payments already made to the Contractor, and any amounts withheld by the City to settle claims against or to pay indebtedness of the Contractor in accordance with the provisions of this Purchase Order. The City has no obligation under any circumstance to make any payment to Contractor for services that have not been performed or that are performed after the termination date.

Termination for Convenience: The City reserves the right, in its best interest as determined by the City, to cancel this Purchase Order for convenience by giving written notice to the Contractor at least thirty (30) days prior to the effective date of such cancellation. In the event this Purchase Order is terminated for convenience, Contractor shall be paid for any services performed to the City's satisfaction pursuant to the Purchase Order through the termination date specified in the written notice of termination. The Contractor acknowledges and agrees that Contractor has received good, valuable, and sufficient consideration from City, the receipt and adequacy of which are hereby acknowledged by the Contractor, for City's right to terminate this Purchase Order for convenience. The Contractor will not be paid on account of loss of anticipated profits or revenue or other economic loss arising out of or resulting from such termination.

Termination by Vendor: Vendor shall have the right to terminate services only in the event of the City failing to pay Vendor's properly documented and submitted invoice within ninety (90) calendar days of the approval by the City's Administrative Agent, or if the project is suspended by the City for a period greater than ninety (90) calendar days.

12. PROPRIETARY OR CONFIDENTIAL INFORMATION: Bidders are hereby notified that all information submitted as part of, or in support of bid submittals will be available for public inspection after opening of bids in compliance with Chapter 119 of the Florida Statutes, the Public Record Act. The Bidder should not submit any information in response to this solicitation which the Bidder considers proprietary or confidential. The submission of any information to the City in connection with this solicitation shall be deemed conclusively to be a waiver of any protection from release of the submitted information unless such information is exempt from disclosure under the Public Records Act, and such information is marked as exempt. Failure to mark a trade secret as exempt waives the exemption.

13. RULES, REGULATIONS AND LICENSES: The vendor shall comply with all federal, state, and local laws and regulations applicable to provision of the goods and/or services specified in this solicitation.

It shall be the responsibility of the Contractor to assure compliance with OSHA, EPA and/or other local, federal, or State of Florida rules, regulations or other requirements, as each may apply.

When applicable and as required by law, the Bidder will provide a material safety data sheet with each delivery of a toxic substance.

The vendor shall maintain books, records, documents, and other evidence directly pertaining to or connected with the services under this Agreement which shall be available and accessible at the Vendor's offices for the purpose of inspection, audit, and copying during normal business hours by the City, or any of its authorized representatives. Such records shall be retained for a minimum of five (5) years after completion of the services.

14. CODE OF ETHICS: With respect to this bid, if any Bidder violates or is a party to a violation of the Florida Statutes, Chapter 112, Part III, Code of Ethics for Public Officers and Employees, such Bidder may be disqualified from furnishing the goods or services for which the bid is submitted and shall be further disqualified from submitting any future bids for goods or services for the City.

15. COLLUSION: By offering a submission to this RFB, the Bidder certifies that the Bidder has not divulged to, discussed or compared his/her bid with other Bidders and has not colluded with any other Bidder or parties to this bid whatsoever. Also, Bidder certifies, and in the case of a joint bid each party thereto certifies as to his/her own organization, that in connection with this bid: any prices and/or cost data submitted have been arrived at independently, without consultation, communication, or agreement, for the purpose of restricting competition, as to any matter relating to such prices and or cost data, with any other Bidder or with any competitor: any prices and/or data quoted for this bid have not been knowingly disclosed by the Bidder and will not knowingly be closed by the Bidder prior to the scheduled opening directly or indirectly to any other Bidder or to any competitor: no attempt has been made or will be made by the Bidder to induce any other person or firm to person or persons interested in this bid, principal or principals is/are named therein and that no person other than therein mentioned has any interest in this bid or in the Contract to be entered into: and no person or agency has been employed or retained to solicit or secure this Contract upon an agreement or understanding for a commission, percentage, brokerage, or contingent fee excepting bona fide employees of the Bidder.

16. PUBLIC ENTITY CRIMES: In accordance with Florida Statutes Sec. 287.133(2)(a), "A person or affiliate who has been placed on the convicted vendor list following a conviction for a public entity crime may not submit a bid on a Contract to provide any goods/services to public entity, may not submit a bid on a Contract with a public entity for construction or repair of public building or public work, may not submit bids on leases of real property to a public entity, may not be awarded or perform work as a Contractor, supplier, subcontractor, or consultant under a Contract with any public entity, and may not transact business with any public entity in excess of the threshold amount provided in Sections 287.017, for Category Two, for a period of 36 months from the date of being placed on the convicted vendor list." By submitting a bid, vendor certifies that vendor is not currently prohibited from transacting business with the City due to the above statute. The vendor shall comply with the terms of this statute both before and during the term of this Contract.

17. DRUG FREE WORKPLACE PREFERENCE: The City has adopted a policy in observation of the Drug Free Workplace Act of 1988. Therefore, it is unlawful to manufacture, distribute, dispense, possess, or use any controlled substance in the City workplace.

The City requests that the attached Drug Free Workplace Affidavit accompany the bid response. This form has been adopted by the City in accordance with the Drug Free Workplace Act. The City will not disqualify any Bidder who does not sign the affidavit. The Drug Free Workplace Affidavit is primarily used as a tie breaker when two or more separate entities have submitted bids at the same price, terms and conditions, with preference given to the Bidder who has signed the affidavit.

18. EQUAL EMPLOYMENT OPPORTUNITY: The City, consistent with the provisions of Title VII of the Civil Rights Act of 1964 ("Title VII") and the regulations issued pursuant to Title VII and Florida Statutes Section 287.09451, states that in any

contract entered into pursuant to any advertisement, minority business enterprises will be afforded full opportunity to submit replies in response to any advertisement and will not be discriminated against on the grounds of race, color or national origin in consideration for an award.

19. NON-DISCRIMINATION: The City of North Port does not discriminate on the basis of race, color, national origin, sex, age, disability, family or religious status in administration of its programs, activities or services. Pursuant to F.S §287.134(2)(a), an entity or affiliate who has been placed on the discriminatory vendor list may not submit a bid, proposal, or reply on a Contract to provide any goods or services to a public entity: may not submit a bid, proposal, or reply on a Contract with a public entity for the construction or repair of a public building or public work: may not submit bids, proposals, or replies on leases of real property to a public entity: may not be awarded or perform work as a Contractor, supplier, subcontractor, or consultant under a Contract with any public entity: and may not transact business with any public entity.

20. DECLARATION OF EXEMPTION FROM PUBLIC RECORD:

- A. In accordance with Florida Statutes, Section 119.0701, Contractor shall comply with all public records laws, and shall specifically:
- (1) Keep and maintain public records required by the City to perform the service.
 - (a) The timeframes and classifications for records retention requirements must be in accordance with the General Records Schedule GS1-SL for State and Local Government Agencies. (See <http://dos.dos.state.fl.us/library-archives/records-management/general-records-schedules/>).
 - (b) “Public records” means and includes those items specified in Florida Statutes, Section 119.011(12), as amended from time to time, and currently defined as: All documents, papers, letters, maps, books, tapes, photographs, films, sound recordings, data processing software, or other material, regardless of the physical form, characteristics, or means of transmission, made, or received pursuant to law or ordinance or in connection with the transaction of official business with the City. Contractor’s records under this Purchase Order include but are not limited to, supplier/subcontractor invoices and contracts, project documents, meeting notes, e-mails and all other documentation generated during this Purchase Order.
 - (2) Upon request from the City’s custodian of public records, provide the City, at no cost, with a copy of the requested records or allow the records to be inspected or copied within a reasonable time at a cost that does not exceed the cost provided for by law. All records kept electronically must be provided to the City, upon request from the City’s custodian of public records, in a format that is compatible with the information technology systems of the City.
 - (3) Ensure that project records that are exempt or confidential and exempt from public records disclosure requirements are not disclosed except as authorized by law for the duration of the Purchase Order term and, if the Contractor does not transfer the records to City following completion of the Purchase Order work, for the time period specified in General Records Schedule GS1-SL for State and Local Government Agencies.
 - (4) Upon completion of the Purchase Order work, transfer, at no cost, to the City all public records in Contractor’s possession or keep and maintain public records required by the City to perform the service. If the Contractor transfers all public records to the City upon completion of the Purchase Order work, the Contractor shall destroy any duplicate public records that are exempt or confidential and exempt from public records disclosure requirements. If the Contractor keeps and maintains public records upon the completion of the Purchase Order work, the Contractor shall meet all applicable requirements for retaining public records.

- (5) **IF THE CONTRACTOR HAS QUESTIONS REGARDING THE APPLICATION OF CHAPTER 119, FLORIDA STATUTES, TO THE CONTRACTOR'S DUTY TO PROVIDE PUBLIC RECORDS RELATING TO THIS PURCHASE ORDER, CONTACT THE CUSTODIAN OF PUBLIC RECORDS AT CUSTODIAN OF PUBLIC RECORDS, 4970 CITY HALL BOULEVARD, NORTH PORT, FLORIDA 34286, (941) 429-7056 OR HOTLINE (941) 429-7270; E-MAIL: publicrecordsrequest@northportfl.gov.**

21. FORCE MAJEURE.

A. Should performance of any obligation created under this Purchase Order become illegal or impossible by reason of:

- (1) A strike or work stoppage, unless caused by a negligent act or omission of either Party;
- (2) An act of God, tornado, hurricane, flood, sinkhole, fire, explosion, landslide, earthquake, epidemic, pandemic, quarantine, pestilence, or extremely abnormal and excessively inclement weather;
- (3) An act of a public enemy, act of war, terrorism, effect of nuclear radiation, blockage, insurrection, riot, civil disturbance, state of martial law, or national or international calamity;
- (4) A declared emergency of the federal, state, or local government; or
- (5) Any other like event that is beyond the reasonable control of the non-performing party;

then the performance of the obligation is suspended during the period of, and only to the extent of, the prevention or hindrance, provided that:

- (6) The non-performing party provides written notice within **five (5) calendar days** of the event of *force majeure*, describing the event in sufficient detail, including but not limited to: the nature of the occurrence, a good faith estimate of the duration of the delay, proof of how the event has precluded the non-performing party from performing, and the means and methods for correcting the delay; and continues to furnish timely reports of all actions required for it to commence or resume performance of its obligations under this Purchase Order;
- (7) The excuse of performance is no greater in scope or duration than required by the event of *force majeure*;
- (8) No obligations of either party that arose before the *force majeure* are excused as a result of the event of *force majeure*; and
- (9) The non-performing party uses all reasonable diligence to remedy its inability to perform.

B. Economic hardship of a party does not constitute an event of *force majeure*. A party must not be excused from performance due to forces that it could have reasonably prevented, removed, or remediated prior to, during, or immediately after their occurrence.

C. The non-performing party's affected obligations under this Purchase Order will be temporarily suspended during, but not longer than, the continuance of the event of *force majeure* and a reasonable time thereafter as may be required to commence or resume performance of its obligations. Notwithstanding the above, performance must not be excused

under this Section for a period exceeding two (2) consecutive months, provided that in extenuating circumstances, the City may excuse performance for a longer term.

D. The term of this Purchase Order will be extended by a period equal to that during which the non-performing party's performance is suspended under this Section.

22. GOVERNING LAW AND VENUE: The laws of the State of Florida govern the rights, obligations, and remedies of the parties under this Purchase Order. The exclusive venues for any legal or judicial proceedings in connection with the enforcement or interpretation of this Purchase Order and/or Contract are the Circuit Court of the Twelfth Judicial Circuit in and for Sarasota County, Florida, and the United States District Court for the Middle District of Florida.

23. SUBCONTRACTING: Unless otherwise specified in this solicitation, the vendor shall not subcontract any portion of the work without the prior written consent of the City. The ability to subcontract may be further limited by the Special Conditions. Subcontracting without the prior consent of the City may result in termination of the Contract for default.

24. MODIFICATION OF CONTRACT: Any Contract resulting from this solicitation may be modified by mutual consent of duly authorized parties, in writing through the issuance of a modification to the Contract and/or change order as appropriate. This presumes the modification itself is in compliance with all applicable City procedures.

25. SUCCESSORS AND ASSIGNS: The vendor shall not assign any interest in any Contract resulting from this solicitation and shall not transfer any interest in same (whether by assignment or novation) without prior written consent of the City, except that claims for the money due or to become due to the vendor from the City under any Contract may be assigned to a financial institution or to a trustee in bankruptcy without such approval from the City. Notice of such transfer or assignment due to bankruptcy shall be promptly given to the City.

26. CONTRACTING WITH CITY EMPLOYEES OR BOARD MEMBERS: Any City employee, Board member or member of his or her immediate family seeking to Contract with the City shall seek a conflict of interest opinion from the purchasing manager or their designated representative prior to submittal of a response or application of any type to Contract with the City. The affected employee or Board member shall disclose his or her assigned function within the City and interest or the interest of his or her immediate family in the proposed Contract and the nature of the intended Contract.

Florida Statute §112.313(12) Standards of Conduct for Public Officers, Employees of Agencies, and Local Government Attorneys controls Contracting with City employees or board members, and provides as follows:

(12) EXEMPTION. --The requirements of subsections (3) and (7) as they pertain to persons serving on advisory boards may be waived in a particular instance by the body which appointed the person to the advisory board, upon a full disclosure of the transaction or relationship to the appointing body prior to the waiver and an affirmative vote in favor of waiver by two-thirds vote of that body. In instances in which appointment to the advisory board is made by an individual, waiver may be effected, after public hearing, by a determination by the appointing person and full disclosure of the transaction or relationship by the appointee to the appointing person. In addition, no person shall be held in violation of subsection (3) or subsection (7) if:

(b) The business is awarded under a system of sealed, competitive bidding to the lowest or best Bidder and:

1. The official or the official's spouse or child has in no way participated in the determination of the bid specifications or the determination of the lowest or best Bidder:

2. The official or the official's spouse or child has in no way used or attempted to use the official's influence to persuade the agency or any personnel thereof to enter such a Contract other than by the mere submission of the bid: and

3. The official, prior to or at the time of the submission of the bid, has filed a statement with the Commission on Ethics, if the official is a state officer or employee, or with the supervisor of elections of the county in which the agency has

its principal office, if the official is an officer or employee of a political subdivision, disclosing the official's interest, or the interest of the official's spouse or child, and the nature of the intended business.

27. TRUTH-IN-NEGOTIATIONS CERTIFICATE: If applicable, execution and signature by the vendor of the Bid Form shall act as the execution of a truth-in-negotiation certificate certifying that the wage rates and costs used to determine the compensation provided for in this Contract are accurate, complete, and current as of the date of the Contract.

For professional service Contracts, the original Contract price and any additions thereto will be adjusted to exclude any significant sums by which the City determines the Contract price was increased due to inaccurate, incomplete, or noncurrent wage rates and other factual unit costs. The City shall exercise its rights under this "Certificate" within one (1) year following payment.

28. GRANT FUNDING: The City will be seeking funding from various agencies.

29. PERFORMANCE/PAYMENT BOND: The successful Bidder shall provide the required performance and payment bond or other acceptable security to the City within **ten (10) business days of being awarded the bid. Failure by the successful Bidder to provide the bond within ten (10) business days shall be considered a default under Sec. 2-404 of the City of North Port Administrative Code.** Such default shall only be curable at the option of the City. In addition, the Contractor shall be responsible and bear all costs associated to record Performance and Payment Bond with Sarasota County Clerk's Office. Receipt of said recording and certified copy of the bond shall be furnished to the Purchasing Department at the time of the pre-construction meeting. Such default shall only be curable at the option of the City.

In addition, the Contractor shall be responsible and bear all costs associated to record Performance and Payment Bond with Sarasota County Clerk's Office. Receipt of said recording and certified copy of the bond shall be furnished to the Purchasing Department at the time of the pre-construction meeting. Such default shall only be curable at the option of the City.

Upon such default, the City may immediately award the bid to the next lowest responsive and responsible Bidder and recover from the original successful Bidder the difference in cost between the original winning bid and the next lowest responsive and responsible Bidder.

PERFORMANCE/PAYMENT BOND REQUIREMENTS: The Contractor shall provide a Performance Bond and a Payment Bond, in the form prescribed in Section 3, Contract Documents, each in the amount of 100% of the Contract amount, the costs of which are to be paid by the Contractor. The bonds will be acceptable to the City only if the following minimum conditions are met:

- a. is licensed to do business in the State of Florida:
- b. holds a certificate of authority authorizing it to write surety bonds in this state:
- c. has twice the minimum surplus and capital required by the Florida Insurance Code at the time the invitation to bid is issued:
- d. is otherwise in compliance with the provisions of the Florida Insurance Code: and holds a currently valid certificate of authority issued by the United States Department of Treasury under 31 U.S.C. §§ 9304-9308.
- e. The Surety Company must have a current rating of at least Excellent (A or A-) as reported in the most current Best Key Rating Guide, published by A.M. Best Company, Inc., of 75 Fulton Street, New York, New York 10038, with an underwriting limitation **of at least two times the dollar amount of the Contract.**

If the Surety Company for any Bond furnished by the Contractor files for bankruptcy, has a receiver appointed, is declared bankrupt, becomes insolvent, has an assignment made for the benefit of creditors, has its right to do business terminated in the State of Florida, or ceases to meet the requirements imposed by the Contract Documents, the Contractor shall, within five (5) calendar days thereafter, substitute another Bond and Surety Company, both of which shall be subject to the City's approval.

By execution of these bonds, the Surety Company acknowledges that it has read the surety qualifications and surety obligations imposed by the Contract documents and hereby satisfies those conditions.

30. STATE REGISTRATION REQUIREMENTS: Any Bidder required by Florida law to register to do business in this state shall either be registered or have applied for registration with the Florida Department of State in accordance with the provisions of Chapter 607, 608, 617, or 621, Florida Statutes, unless they are exempt. A copy of the registration/application may be required prior to award of a Contract. Any partnership submitting a bid in response to this RFB shall have complied with the applicable provisions of Chapter 620, Florida Statutes.

31. NOTICE TO PROCEED/DELIVERY: After award of bid, a Notice to Proceed shall be issued bearing the terms of delivery. Upon receipt of Notice to Proceed, successful Bidder shall acknowledge receipt of same by either fax or mail and shall commence prosecution of the order so that the agreed upon delivery date will be satisfied.

32. PERFORMANCE EVALUATION: At the end of the Contract, the receiving department may evaluate the successful Bidder's performance. This evaluation will become public record.

33. PURCHASING AGREEMENTS WITH OTHER GOVERNMENTAL AGENCIES: All Bidders submitting a response to this RFB agree that such response also constitutes a bid in accordance with the terms of the RFB to all political subdivisions of Sarasota County and the State of Florida, under the same conditions, for the same prices as this bid, unless otherwise stipulated by the Bidder.

34. NONEXCLUSIVE CONTRACT: Award of this Contract shall not require the City to use the Vendor for all work of this type, which may develop during the Contract term. This Contract is non-exclusive. The City reserves the right to concurrently Contract with other entities for similar work if it deems such action to be in the best interests of the City.

35. AUDIT: City shall have the right to audit Vendor's records that relate to this Contract. Records shall be maintained for a period of three (3) years from the date of final payment.

36. UNAUTHORIZED ALIEN WORKERS: The City will not intentionally award publicly-funded Contracts to any Contractor who knowingly employs unauthorized alien workers, constituting a violation of the employment provisions contained in U.S.C. Section 1324a(e) [Section 274A(e) of the Immigration and Nationality Act ("INA")]. The City shall consider employment by any Contractor of unauthorized aliens a violation of Section 274A(e) of the INA. Such violation by the Contractor of the employment provisions contained in Section 274A(e) of the INA shall be grounds for termination of this Agreement by the City.

37. EMPLOYEE BACKGROUND CHECK: If an owner, except a stockholder in a publicly traded corporation, or an employee of the Contractor has been convicted of any offenses requiring registration as a sexual offender or sexual predator, regardless of the location of conviction, the Contractor shall ensure that the offender's or predator's work on the project is consistent with the terms of their probation and registry requirements.

38. PAYMENT: One (1) original requests for payment must be submitted to the City of North Port on a form approved by the City. In lieu of the hard copies of the pay request submittal, scanned signed digital files of the requests for payments may be submitted as an attachment to an e-mail. Each pay request must be accompanied by written consent of the surety, when applicable, and an updated work schedule to reflect progress of work. Payment shall be subject to the approval and direction of the surety in accordance with F.S. §255.05(11). Price shall be net and all invoices payable according to the Florida Local Government Prompt Payment Act (F.S. ch. 218). Upon certification and approval by the City or its duly authorized agent, progress payments may be made to the Contractor upon his/her application for all services or work completed or materials furnished in accordance with the Contract. Prior to fifty percent (50%) completion, the Contractor will be paid monthly the total value of the work completed and accepted during the preceding month, less five percent

(5%) retainage. After fifty percent (50%) completion of the construction services purchased pursuant to the Contract, the City will not reduce the amount of retainage withheld from each subsequent progress payment made to the Contractor upon request of the Contractor. For purposes of this subsection, the term "fifty percent (50%) completion" is the point at which the City has expended fifty percent (50%) of the total cost of the construction services purchased as identified in the Contract together with all costs associated with existing change orders and other additions or modifications to the construction services provided for in the Contract. The City shall inform the Contractor's Surety of any reduction in retainage. The Contractor must update each new pay request in accordance with any changes made to the previous submittal. The City or its duly authorized administrative agent, shall approve final payment for all work, materials and services furnished under this Contract.

Retainage may be reduced upon issuance of the Certificate of Substantial Completion by the City if, in the sole opinion of the City, sufficient progress on the schedule has been accomplished, the surety does not object, and the City has retained adequate coverage for the project through the achievement of Final Completion.

39. MBE: Contractors awarded construction Contracts who intend to subcontract material or service requirements of the project are encouraged to subcontract to certified minority business/women business enterprises firms or show good faith effort.

40. DBE Contract Assurance (IF APPLICABLE): The Contractor, sub-recipient, or subcontractor shall not discriminate on the basis of race, color, national origin, or sex in the performance of this Contract. The Contractor shall carry out applicable requirements of 49 CFR Part 26 in the award and administration of DOT assisted Contracts. Failure by the Contractor to carry out these requirements is a material breach of this Contract, which may result in the termination of this Contract or such other remedy as the recipient deems appropriate.

41. SWORN STATEMENT, COMPLIANCE WITH FLORIDA TRENCH ACT: Bidder shall be solely responsible for complying with the Florida Trench Safety Act (553.60-553.64 Florida Statutes) and Occupational Safety and Health Administration excavation safety standards, 29 CFR 1926.650 (subpart P) as amended. All costs associated with complying with these requirements shall be included in the separate line items of the bid and shall be as detailed in the Sworn Statement of Compliance with the Florida Trench Safety Act. Bidder shall submit the Statement of Compliance with the Florida Trench Safety Act form provided herein with his bid or with each work assignment.

42. INSURANCE REQUIREMENTS: The successful Bidder shall be required to supply, at their cost, insurance coverage in form and amount as required by the City, as outlined in the bid specifications.

43. CONTACT PROHIBITION: All prospective Bidders are hereby instructed **NOT** to contact any member of the City of North Port Commission, the City Manager, or City of North Port staff member other than the Authorized Contact Persons identified in this Solicitation regarding this solicitation package, Bidder's submittal package, City's Intent to Award, or City's Intent to Reject (if applicable) at any time prior to the FORMAL AWARD for this project. Any such contact shall be cause for rejection of your submittal.

44. SCRUTINIZED COMPANIES:

A. Certification. As required by Florida Statutes Section 287.135(2), for contracts of any amount, the Contractor must certify on a form provided by the City, that it is not on the Scrutinized Companies that Boycott Israel List, created pursuant to Florida Statutes Section 215.4725, and that it is not engaged in a boycott of Israel.

B. Requirements. As required by Florida Statutes Section 287.135(5), for contracts of \$1,000,000 or more, the Contractor must certify on a form provided by the City, that all of the following are true:

- (1) Contractor is not on the Scrutinized Companies that Boycott Israel List, created pursuant to Florida Statutes Section 215.4725, and that it is not engaged in a boycott of Israel; and
- (2) Contractor is not on the Scrutinized Companies with Activities in Sudan list or the Scrutinized Companies with Activities in Iran Petroleum Energy Sector List, created pursuant to Florida Statutes Section 215.473; and
- (3) Contractor is not engaged in business operations in Cuba or Syria.

C. Termination. If the Contractor provides a false certification or has been placed on one of the above-noted Lists of Scrutinized Companies or has engaged in business operations in Cuba or Syria, the Contractor will be in breach of this Purchase Order and the City may terminate the Purchase Order.

D. Penalty.

- (1) A Contractor that has been found to have provided a false certification may be subject to a civil penalty equal to the greater of \$2 million or twice the amount of this Purchase Order, plus all reasonable attorneys' fees and costs, including any costs for investigations that led to the finding of the false certification; and
- (2) Will be ineligible to bid on any Purchase Order with the City for three (3) years after the date the City determined that the Contractor submitted a false certification.

45. LOCAL PREFERENCE – NOT APPLICABLE for this project.

46. CONFLICTS OF INTEREST – CITY OFFICERS, EMPLOYEES OR BOARD MEMBERS: The Florida Code of Ethics regulates the ability of the City to Contract with its public officers (including board members), employees, and their immediate relatives. Respondents shall disclose any such potential conflicts on the provided Conflict of Interest Form. Respondents are responsible for reviewing Florida Statute §112.313 to determine whether they may have a conflict. If Respondent is in doubt as to their ability to Contract with the City, they shall seek a conflict of interest opinion from the City Manager or his/her designated representative prior to submittal of a response.

47. RELEASE OF LIENS: The Contractor is required to pay all money due subcontractors and material dealers promptly. The Contractor shall submit releases of liens, satisfactory to the City, certifying that all payrolls, material bills, and other indebtedness incurred by the Contractor in connection with this project have been paid in full.

48. DIRECT PURCHASE: The City reserves the right, at the City's sole option, to utilize the Purchasing Department's direct purchase order system. Direct purchase orders may be issued for applicable supplies and equipment to utilize in this project in order to recover applicable sales tax on these purchase orders.

49. E- VERIFY: The City, contractor and every subcontractor shall register with and use the E-Verify system of the United States Department of Homeland Security to verify the work authorization status of all new employees as required by Section 448.095, Florida Statutes. A contractor who enters into a contract with a subcontractor, must require that the subcontractor provides the contractor a certification by affidavit stating that at the time of such certification and during the term of the contract, the subcontractor does not and will not employ, contract, or subcontract with an unauthorized alien, who is not authorized under federal law to be employed in the United States, as described in 8 U.S.C. S. 1324A(H)(3). The Contractor shall comply with all other federal laws pertaining to the subcontractor.

50. BUY AMERICA: The City is committed to the procurement of products and services that are produced or manufactured in America. The city encourages all contractors and vendors to buy American made materials and products.

END OF SECTION I

SECTION II. GENERAL PROVISIONS

1. SCOPE OF WORK

1.1 Intent of Contract: Bid forms shall set forth firm bid unit prices for furnishing all necessary materials and completing all work, including but not limited to labor, transportation, supervision, electricity, water, equipment, startup, testing, training and all other work needed for a complete and operational system, as described in the Technical Specifications and/or shown on the Contract Drawings (If applicable) attached herewith. The City reserves the right to establish the exact limits of work in the field and to add or delete from the Project, as it deems necessary.

The intent of the Technical Specifications and Contract Drawings, as applicable, is to describe a complete project to be constructed in accordance with the Contract Documents. The Contract Documents comprise the entire Agreement between the City and the Contractor. They may be altered only by addendum or change order approved by the City.

1.2 Definitions:

1.2.1 The successful Bidder for this Contract will be referred to as the **CONTRACTOR**: Department Director or his/her representative, acting personally or through an assistant duly authorized for such act by the City will be referred to as City. For the purposes of this Contract, the word "Project" shall mean the services limits of **CONTRACTOR**.

1.2.2 The Contract documents consist of the Request for Bids, Instructions to Bidders, Bid Forms, Technical Specifications, Construction Drawings, General Provisions, Special Provisions, Insurance Requirements, and all other related documents, including all modifications thereof incorporated in the documents before their execution. These form the Contract.

1.2.3 Written notice shall be deemed to have been duly served three days after date of postmark, and upon receipt, if delivered to the individual or member of the firm or an officer of the corporation for whom it is intended.

1.2.4 Subcontractor(s), as employed herein, includes only those having a direct Contract with the Contractor and it includes one who furnishes material worked to a special design according to the plans and specifications of this work, but does not include one who merely furnishes material not so worked.

1.2.5 The term "work" of the Contractor includes labor or materials or both, equipment, transportation, or other facilities necessary to complete the Contract.

1.2.6 All time limits stated in the Contract documents are of essence to the Contract.

1.2.7 The words "furnish," "furnish and install," "install," and "provide" or words with similar meaning shall be interpreted, unless otherwise specifically stated, to mean "furnish and install complete in place and ready for service."

1.3 Time of Completion: The Contractor shall complete the work within the time set forth in the Contract. The Contractor shall complete each portion of the work within such time as set forth in the Contract for such portion. The time of completion of the Contract shall be expressed in calendar days.

All work for this project shall be performed during regular business hours. A regular workday shall be considered to be a maximum of ten (10) hours duration. The cost for inspection time for work performed on weekends, holidays, or in excess of ten (10) hours may be billed to the Contractor at the prevailing wage plus overhead costs for those persons involved.

A working day is any day within the period between the start of the Contract time and the date provided in the Contract for completion or upon field acceptance by the City of all work provided for in the Contract, or as stipulated in the Technical Specifications, or whichever comes first, other than: **Saturday, Sunday, any day designated as a holiday by the City, any day the Contractor is prevented from working during the first five (5) hours of the work day, with at least sixty percent (60%) of the normal work force, due to inclement weather.**

Request for planned overtime by the Contractor must be submitted in writing to the City, forty-eight (48) hours in advance, and may not proceed without the City's approval.

1.4. Quality of Work: The Contractor agrees to do the work covered under this Contract to the best of his/her ability and conforming to this Contract and specifications and of a quality acceptable to the trades. The Contractor further agrees to follow proper and appropriate instructions by the City.

2. PROSECUTION AND PROGRESS

2.1 Subletting or Assigning of Contracts: The Contractor shall not sublet, sell, transfer, assign, or otherwise dispose of the Contract or any portion thereof, or his right, title, or interest therein, without written consent of the City.

2.2 Preconstruction Meeting: After the Contract has been awarded, the City will schedule a preconstruction meeting to be held before any work is begun to review the construction aspects of the Project. The meeting will be between the City and the Contractor.

2.3 Performance and Payment Bond: The awarded Contractor shall furnish a certified recorded copy from Sarasota County Clerk's Office of the Performance and Payment Bond in the amount of 100% of the total project price within ten (10) calendar days after notification of award to the Purchasing Department. The undersigned shall be responsible and bear all costs associated to record Performance and Payment Bond with Sarasota County Clerk's Office. Receipt of said recording and a certified copy of the Bond shall be furnished to the Purchasing Department at the time of the pre-construction meeting.

2.4 Submission of Work Schedule/Order of Completion: At the preconstruction meeting, the successful Bidder shall have on hand a working schedule for the Project, showing in detail the order in which the Contractor proposes to perform the work. He/she shall indicate the dates on which major equipment will be delivered and various major items of work will start and the estimated completion dates of the major items. Construction Schedule provides additional information for ongoing scheduling requirements associated with this Contract.

2.5 Submission of Schedule of Values: A Schedule of Values to reflect value of equipment, materials and work performed per unit price, with totals shall be submitted at preconstruction meeting. Both parties are to agree on proposed schedule of values prior to any work being performed.

2.6 Provisions for Convenience of Public: The Contractor shall schedule his/her operations so as minimize any inconvenience to adjacent businesses for residences. Where necessary, the City may require the Contractor to construct first the work in any areas along the Project where restrictions caused by construction operations would represent a more serious handicap, before beginning construction in the less affected areas.

3. CONTROL OF THE WORK AND MATERIALS

3.1 Control of Work:

3.1.1 Plans and Contract Documents: If required for the project, the Contractor will be furnished a universal serial bus flash drive and four (4) signed and sealed building permit 11"x17" copies of the Plans, Technical Specifications, General and Special Provisions. Additional signed & sealed copies, if needed to obtain permits for the Work associated with this Contract, will be submitted upon written request. Other copies that may be needed by the Contractor shall be produced by the Contractor at his own expense.

3.1.2 Detail Drawings and Instructions: The City may furnish, with reasonable promptness, additional instructions by means of drawings or otherwise, necessary for the proper execution of the work. All such drawings and instructions shall be consistent with the Contract documents, true developments thereof, and reasonably inferable there from.

3.1.3 Order of Precedence: These documents are integral parts of the Contract, and a requirement occurring on one is as binding as though occurring in all. They are intended to be complementary and to describe and provide for a complete work. In cases of discrepancy, the governing order of documents shall be as follows:

- 3.1.3.1 Permits from Agencies as required by law
- 3.1.3.2 Change Orders
- 3.1.3.3 Contract Documents, General Provisions and Special Provisions in that order
- 3.1.3.4 Technical Specifications
- 3.1.3.5 Construction Plans
 - 3.1.3.5.1 Dimensions given in figures govern scaled dimensions.
 - 3.1.3.5.2 Detail drawings govern over general drawings.
 - 3.1.3.5.3 Addenda/Change order drawings govern over Contract documents.
- 3.1.3.6 FDOT Roadway and Traffic Design Standards, latest edition.
- 3.1.3.7 FDOT Standard Specifications, for Road & Bridge Construction, latest edition.

3.1.4 *Conformity of Work with Plans:* All work performed and all materials furnished shall be in reasonably close conformity with lines, grades, cross sections, dimensions, and material requirements, including tolerances, shown on the Plans or indicated in the Technical Specifications or Special Provisions.

3.1.5 *Authority of the City:* All work shall be done under the supervision of the City or the City's representative and performed to its satisfaction. It is agreed by the parties hereto that the City shall decide all questions and disputes which may arise relative to the interpretation of the plans, construction, prosecution, and fulfillment of the Contract, and as to the character, quality, amount, and value of any work done, and material furnished, under or by reason of the Contract.

3.1.6 *City's Status:* The City and/or the City's Representative shall examine and inspect the work to assure compliance with the requirements of these Contract Documents. The City and/or the City's Representative shall determine the quality and acceptability of materials and workmanship relative to the requirements of the Plans and Technical Specifications.

The City has the authority to:

- 3.1.6.1 Stop the work whenever such stoppage may be necessary to insure the proper execution of the Contract.
- 3.1.6.2 Reject all work that does not conform to the Contract.
- 3.1.6.3 Resolve questions that arise in the execution of the work.

The City's Representative has the authority to:

- 3.1.6.4 Reject all work that does not conform to the Contract.
- 3.1.6.5 Resolve questions that arise in the execution of the work.

3.1.7 *Suspension of Work:* The City may at any time suspend work by giving ten (10) calendar days notice to the Contractor in writing. The City shall reimburse the Contractor for expenses incurred by the Contractor in connection with work under the Contract as a result of such suspension, unless such suspension was caused by actions of the Contractor. However, if the work or any part thereof shall be stopped by a notice in writing aforesaid, and if the City does not give written notice to the Contractor to resume work within thirty (30) calendar days of the date fixed in the written notice to suspend, then the Contractor will be entitled to the estimates and payment for all work done, unless such suspension was caused by actions of the Contractor.

3.1.8 *The City's Right to do Work:* If the Contractor should neglect to prosecute the work properly or fail to perform in accordance with the provisions of this Contract, the City, after three days written notice, may without prejudice to any other remedy it may have, make good any deficiencies and deduct from the payment due the Contractor.

3.1.9 The City's Right to Terminate Contract: If the Contractor refuses or fails to complete the work within the time specified for this Contract, or any extension thereof, the City may terminate the Contractor's right to proceed. In such event, the City may take over the work and prosecute the same to completion by the Contract or otherwise and the Contractor will be liable for any excess cost occasioned by the City. The City may take possession of and utilize in completing the work such materials and equipment as may be on the site of the work and necessary, therefore:

If the Contractor should be adjudged bankrupt, or should make a general assignment for the benefit of his/her creditors, or if a receiver should be appointed due to insolvency, or if he/she should refuse or fail, except in cases which a time extension is provided to supply enough personnel, or if he/she should fail to make payment to subcontractors for labor and/or material, or disregard laws, ordinances or the instructions of the City, or be guilty of a violation of a provision of the Contract, then the City may, without prejudice to any other right or remedy and after giving seven (7) calendar days' notice, terminate employment of the Contractor and possess materials, tools, and appliances thereon and finish work by methods it may deem expedient. Expenses incurred by the City and the damage incurred through the Contractor's default shall be borne by the Contractor.

In any circumstance, the City shall have the right to unilaterally cancel, terminate or suspend this Contract, in whole or in part, by providing the Contractor thirty (30) calendar days written notice by certified mail.

In the event of termination, the Contractor shall be entitled to compensation for services rendered and costs incurred through the effective date of termination. All finished or unfinished documents, material, or work shall become the property of the City and shall be delivered to the City without reservation.

3.1.10 City May Stop the Work: If the Work is defective, or the Contractor fails to supply sufficient skilled supervisory personnel or workers or suitable materials or equipment or the work area is deemed unsafe, the City may order the Contractor to stop the Work, or any portion thereof, until the cause for such order has been eliminated: however, this right of the City to stop the Work shall not give rise to any duty on the part of the City to exercise this right for the benefit of the Contractor or any other party. The City will not award any increase in Contract Price or Contract Time if the Work is stopped due to the circumstances described herein.

3.1.11 City's Decision: The City shall, within a reasonable time after their presentation, make decisions in writing on claims by the Contractor and on all other matters relating to the execution and progress of the work or the interpretation of the Contract Documents.

3.1.12 Authority and Duties of City's Inspectors: The City's Inspectors shall be authorized to inspect all work done and all materials furnished. They shall be authorized to call to the attention of the Contractor any failure of the work or materials to conform to the Technical Specifications and Contract. The presence of the Inspector shall in no way lessen the responsibility of the Contractor.

3.1.13 Inspection of Work: The City and its representative shall at all times have access to the work wherever it is in preparation or progress and the Contractor shall provide proper facilities for such access and inspection. If the Specifications/Conditions, the City's instruction, laws, ordinances or any public authority require any work to be specially tested or approved, the Contractor shall give to the City timely notice of its readiness for inspection and, if the inspection is by an authority other than the City, the date fixed for such inspection. Inspections by the City shall be promptly made and, where practicable, at the source of supply. If any work should be covered up without approval or consent of the City, it must, if required by the City, be uncovered for examination at the Contractor's expense. Re-examination of questioned work may be ordered and the work must be uncovered by the Contractor.

3.1.14 Contractor's Supervision and Employees: The Contractor shall supervise, inspect, and direct the work completely and efficiently, devoting such attention thereto and applying such skills and expertise as may be necessary to perform the work in accordance with the Contract Documents. The Contractor shall be solely responsible for the means, methods, techniques, sequence and procedures necessary for the orderly progress of the work, and to maintain all safety precautions and programs incidental thereto. The Contractor shall at all times enforce strict discipline and good order among his/her employees and shall not employ any unfit person or anyone unskilled in the work assigned to him/her. The Contractor shall be responsible to see that the completed work complies fully with the Contract Documents.

The Contractor will employ and maintain on the Work a qualified supervisor or superintendent who shall have been designated in writing by the Contractor as the Contractor's representative at the site. The supervisor shall have full authority to act on behalf of the Contractor and all communications given to the supervisor shall be as binding as if given to the Contractor.

As the work progresses, the Contractor shall keep on the job at all times an English-speaking Supervisor, Superintendent or designee, technically qualified, who is an employee of the Contractor and who shall not be replaced without written notice and approval of the City. The Superintendent or his/her qualified designee shall be present at the job site and direct the work of subcontractors, as well as employees of the Contractor. This supervisor will be equipped with a communication device enabling him/her to contact suppliers, subcontractors or his/her office who in turn can convey necessary communications to others. The Contractor shall issue all communications to the City or his/her representative.

The Contractor's Superintendent shall be present on the job site **at all times** while work is in progress and shall be available by phone for emergencies twenty-four hours per day, seven days per week. Failure to observe this requirement shall be considered suspension of the work by the Contractor until such time as such Superintendent is again present on the job.

If the Contractor, in the course of the work, finds any discrepancy between the drawing and the physical conditions of the site, or any errors or omissions in drawing, or in the construction layout points and instructions, he/she shall immediately inform the City, in writing, and the City shall promptly verify same. Any work done after such discovery will be done at the Contractor's risk.

Neither party shall employ or hire any employee of the other party without the concurrence of each party.

3.1.15 Contractor's Understanding: It is understood and agreed that the Contractor has, by careful examination, satisfied himself/herself as to the nature and locations of the work, the conformation of the ground, the character, quality, and quantity of materials to be encountered, the character of equipment and facilities needed prior to and during prosecution of the work under this Contract. No verbal agreement or conversation with any officer, agent, or employee of the City, either before or after execution of this Contract, shall affect or modify the terms or obligations herein contained.

3.1.16 Permits and Regulations: Permits and licenses necessary for the prosecution of the work shall be secured by the Contractor unless otherwise specified. The Contractor shall give all notices and comply with all laws, ordinances, rules, and regulations bearing on the conduct of the work as drawn and specified. If the Contractor observes that the specifications and drawings are at variance therewith, Contractor shall promptly notify the City in writing, and any necessary changes shall be adjusted as provided in the Contract for changes in the work. If the Contractor performs any work knowing it to be contrary to such laws, ordinances, rules, and regulations, and without such notice to the City, he/she shall bear all costs arising there from.

3.1.17 Protection of Work and Property: The Contractor shall continuously maintain protection of all his/her work from damage and shall protect the City's property from injury or loss arising in connection with this Contract. He/she shall adequately protect adjacent property as provided by law and the Contract Documents. He/she shall provide and maintain all passageways, guard fences, lights, and other facilities for protection required by public authority or local conditions. In an emergency affecting the safety of life or of the work, or of adjoining property, the Contractor, without special instruction or authorization from the City, is hereby permitted to act, at their discretion, to prevent such threatened loss or injury, and he/she shall so act, without appeal, if so instructed or authorized. Any compensation claimed by the Contractor on account of emergency work shall be determined by agreement between the Contractor and the City.

The Contractor shall not occupy private land outside of any easements or rights of way unless a written authorization has been signed by the property owner. It shall be the Contractor's responsibility to obtain and provide these agreements prior to construction, if required. Prior to the use of private lands, the Contractor shall submit a copy of the agreement(s) to the City. In the event the Contractor uses private property for any purpose without first having obtained the necessary approvals from the property owner and provided the necessary agreements to the City, the City will direct the Contractor in writing to immediately cease using such property.

Prior to application for final payment, the Contractor shall provide documentation from the owner of each piece of private property for which an agreement for use was provided, or for which the City has issued written notification to the Contractor, that each owner is satisfied with the manner in which the Contractor has restored the property. Final payment or reduction in retainage shall not be paid until such documentation is received by the City.

3.1.18 Changes in the Work: The City, without invalidating the Contract, may order extra work or make changes by altering, adding to or deducting from the work, the Contract sum being adjusted accordingly. Such work shall be executed under the conditions of the original Contract. The change and amount of compensation must be agreed upon in writing in a document of equal dignity herewith prior to any deviation from the terms of this Contract.

In giving instructions, the City shall have authority to make minor changes in the work, not involving extra cost, and not inconsistent with the purposes of the work. Except in an emergency endangering life or property, no extra work or change shall be made unless in pursuance of a written order by the City; and no claim for an addition to the Contract sum shall be valid, unless ordered. Value of any such extra work or change shall be determined in one or more of the following ways:

- 3.1.18.1** By estimate and acceptance in a lump sum.
- 3.1.18.2** By unit prices named in the Contract or subsequently agreed upon.
- 3.1.18.3** By cost and percentage or by cost and a fixed fee.

If none of the previous methods are agreed upon, the Contractor, provided he/she receives an order as above, shall proceed with the work. In such case and also under case, he/she shall keep amendment in such form as the City may direct, a correct amount of the net cost of labor and materials, together with vouchers. The City shall certify to the amount, including reasonable allowance for overhead and profit, due to the Contractor. Pending final determination of value, no payment on changes shall be made. When requiring a change in the scope of services the Contractor shall notify the City by written notice that a change order is requested within five (5) days of any occurrence.

3.1.19 Deductions for Uncorrected Work: If the City deems it inexpedient to correct work injured or done not in accordance with the Contract, some equitable deductions from the Contract price shall be made thereof.

3.1.20 Delays and Extension of Time: If the Contractor should be delayed at any time in the progress of work by any act of negligence by the City or its employees or by any other Contractor employed by the City, or by changes ordered in the work, or by such causes beyond the Contractor's control, or by delay authorized by the City, or by any cause which the City shall decide to justify the delay, then the time of completion shall be extended for such reasonable time as the City may decide. However, no time delay shall be allowed if judged by the City to be caused by the Contractor's negligence.

No such extension shall be made for delay occurring more than seven (7) calendar days before claim therefore is made in writing to the City. In the case of a continuing cause of delay only one (1) claim is necessary. This article does not exclude the recovery of damages for delay by either party under other provisions in the Contract Documents.

3.1.21 Correction of Work Before Final Payment: All work, materials, whether incorporated in the work or not, all processes of manufacturer, and all methods of construction shall be at all times and places subject to the inspection of the City who shall be the final judge of quality and suitability of the work, materials, processes of manufacture, and methods of construction for the purposes for which they are used. Should they fail to meet City's approval: they shall be forthwith reconstructed, made good, replaced, and/or corrected, as the case may be, by the Contractor at his/her own expense. Rejected material shall be immediately removed from the site. If, in the opinion of the City, any portion of the work injured or not performed in accordance with the Contract Documents, the compensation to be paid to the Contractor hereunder shall be reduced by such amount as the City, in its judgement, finds to be equitable.

3.1.22 Contractor Right to Stop Work or Cancel Contract: If the work should be stopped under an order of any court or other public authority for a period of three (3) months through no act or fault of the Contractor or of anyone employed by him, or if the City fails to pay the Contractor within thirty (30) calendar days of maturity and presentation of any sum certified by the City, then the Contractor may, upon seven (7) calendar days written notice to the City, stop work and terminate this Contract.

3.1.23 Removal of Equipment: In the case of annulment of this Contract before completion from any cause whatever, the Contractor, if notified to do so by the City, shall promptly remove any part or all of his equipment and supplies from property of the City and/or site of work, failing which the City has the right to remove such equipment and supplies at the Contractor's expense.

3.1.24 Use of Completed Portions: The City has the right to take possession of and use any completed or partially completed portions of the work, notwithstanding the time for completing the entire work of such portions may not have expired but taking possession and use shall not be deemed an acceptance of any work not completed in accordance with the Contract Documents. If such prior use increases the cost of or delays the work, the Contractor shall be compensated as the City may determine and the City approves.

3.1.25 Payments Withheld: The City may withhold payment to the Contractor from loss on account of:

- 3.1.25.1** Defective Work not remedied.
- 3.1.25.2** Claims filed or evidence indicating probable filing of claims.
- 3.1.25.3** Failure of the Contractor to make payment properly to Subcontractors or for material/labor.
- 3.1.25.4** A reasonable doubt that the Contract can be completed for the balance then unpaid.

3.1.25.5 Damage to another Contractor.

3.1.26 Damages: Any claim for damage arising under this Contract shall be made in writing to the party liable within a reasonable time of the first observance of such damage and not later than the time of final payment, except as expressly stipulated otherwise in the case of faulty work, and shall be adjusted by agreement.

3.1.27 Assignment: Neither party to the Contract shall assign the Contract or sublet it as a whole without the written consent of the other, nor shall the Contractor assign any monies due or to become due to him/her hereunder without the previous written consent of the City.

3.1.28 Right of Various Interests: Before work being done by the City's forces or by other Contractor's forces, contiguous to work covered by this Contract, the respective rights of the various interests involved shall be established by the City before such commencement, to secure the completion of the various portions of the work in general harmony.

3.1.29 Separate Contracts: The City reserves the right to let other Contracts in connection with this work. The Contractor shall afford other Contractors reasonable opportunity for the introduction and storage of their materials and execution of the work and shall properly connect and coordinate his/her work with theirs. If any part of the Contractor's work depends on proper execution or results upon the work of any other Contractor, the Contractor shall inspect and promptly report to the City any defects in such work that render it unsuitable for such proper execution and results. His/her failure to so inspect and report shall constitute an acceptance of the other Contractor's work as fit and proper for the reception of his work, except as to defects, which may develop on the other Contractor's, work after execution of his work.

3.1.30 Subcontractors: The Contractor shall provide a list of Subcontractors with his/her proposal for approval. The Contractor shall be fully responsible for all acts and omissions of his Subcontractors and of persons and organizations directly or indirectly employed by them and of persons and organizations for whose acts any of them may be liable to the same extent that Contractor is responsible for the acts and omissions of persons directly employed by Contractor. Nothing in the Contract Documents shall create any Contractual relationship between City or City's Engineer of Record and any Subcontractor or other person or organization having a direct Contract with Contractor, nor shall it create any obligation on the part of City or City's Engineer of Record to pay or to see to the payment of any moneys due any Subcontractor or other person or organization, except as may otherwise be required by law. City or City's Engineer of Record may furnish to any Subcontractor or other person or organization, to the extent practicable, evidence of amounts paid to Contractor on account of specific Work done in accordance with the schedule of values.

Substitutions must be submitted in writing and shall be subject to the approval by the City. To ensure proper execution of his/her subsequent work, the Contractor shall measure work already in place and shall at once report to the City any discrepancy between the executed work and the drawings.

Acceptance of any such Subcontractor, person or organization shall not constitute a waiver of any right of the City, City's Representative, or Engineer to reject defective Work, material or equipment: or, Work, material or equipment not in conformance with the requirements of the Contract Documents.

The divisions and sections of the Specifications and the identifications of any Drawings shall not control the Contractor in dividing the Work among Subcontractors or delineating the Work to be performed by any specific trade.

The Contractor agrees to bind specifically every Subcontractor to the applicable terms and conditions of the Contract Documents for the benefit of the City.

All Work performed for the Contractor by a Subcontractor shall be pursuant to an appropriate agreement between the Contractor and the Subcontractor.

The Contractor shall be responsible for the coordination of the trades, Subcontractors and suppliers engaged upon his Work.

- The Contractor shall cause appropriate provisions to be inserted in all subcontracts relative to the Work to bind Subcontractors to the Contractor by the terms of these General Conditions and other Contract Documents insofar as applicable to the Work of Subcontractors, and to give the Contractor the same power in regard to terminating any subcontract that the City may exercise over the Contractor under any provisions of the Contract Documents.
- The City, City's Representative, or Engineer will not undertake to settle any differences between the Contractor and his Subcontractors or between Subcontractors.
- If in the opinion of the City, City's Representative, or Engineer, any Subcontractor on the Project proves to be incompetent or otherwise unsatisfactory, Subcontractor shall be replaced if and when directed in writing.

3.1.31 *Horizontal and Vertical Control:* Unless noted otherwise in the Contract documents, the Contractor shall be responsible for the layout of all Contract work. The Contractor shall employ or retain any/all professional services that are required by the Contract to complete the work. The Contractor shall carefully preserve benchmarks, reference points and stakes, and, in case of willful or careless destruction, be responsible for any mistakes that may be caused by their unnecessary loss or disturbance.

3.1.32 *Lands for Work:* The City shall provide the lands upon which the work under this Contract is to be done, except that the Contractors shall provide land required for the erection of temporary construction facilities and storage of material, together with the right of access to same.

3.1.33 *Cleaning Up:* The Contractor shall, at such times as may be required by the City, remove from the City's property and from all public and private property, at his/her own expense, all temporary structures, used materials and equipment, rubbish and waste materials resulting from his/her operations. All damaged areas will be restored by the Contractor to their original conditions and approved by the City. By submission of a bid, the Contractor assumes full responsibility for the associated expenses. There shall not be an increase in time or price associated with such removal, and payment to Contractor may be withheld until such work is completed.

3.1.34 *Guarantee:* The Contractor shall warrant all equipment furnished and work performed by him/her for a period of one (1) year from the date of written acceptance of the work, final completion by the City or as may be otherwise specified. Any faulty work or equipment will be fully corrected at no cost to the City and restored work will be warranted for one year from the date of acceptance, or as may be otherwise specified. This will not release additional warranties required by other sections or provided by individual suppliers.

The making and acceptance of final payment shall not waive any claim for faulty work appearing after final payment or for failure to adhere strictly to the Contract documents. If any part of the project is guaranteed for a longer period, such longer period shall prevail. Except as otherwise specified, all work shall be guaranteed by the Contractor against defects resulting from use of inferior materials, equipment or workmanship for one (1) year from the date of completion or written acceptance by the City, whichever is later.

3.1.35 Responsibility Regarding Existing Utilities and Structures: The existence and location of underground utilities indicated on the plans are not guaranteed and shall be investigated and verified in the field by the Contractor before submitting a bid. Excavation in the vicinity of existing structures and utilities shall be done by hand. The Contractor shall be responsible for any damage to, and for maintenance and protection of, existing utilities and structures from any damage resulting from said excavation. The Contractor is to include within his line-item bid prices the costs to protect, support, relocate, or move (whether shown or not shown on the proposed project set of plans) all underground utilities, which may be in conflict with the construction of the proposed project.

3.1.36 Accidents: The Contractor shall provide equipment and medical facilities as necessary to supply first aid to anyone who is injured in connection with the work. The Contractor must promptly report in writing to the City accidents arising out of, or in conjunction with the performance of the work, whether in, or adjacent to, the site, which causes death, personal injury, or property damages, giving full details and statements of witnesses. If death or serious injuries or serious damages are caused, the accident shall be reported immediately by telephone or messenger to the City. If a claim is made by anyone against the Contractor or Subcontractor on account of an accident, the Contractor shall promptly report the facts in writing to the City, giving full details of the claim.

3.1.37 Stage Plans: Stage plans of structural alterations, cofferdams, dredging, furnished or approved by the City, shall be adhered to unless objected to in writing by the Contractor, but the submission or approval of stage plans by the City shall not relieve the Contractor of full responsibility for the work.

3.1.38 Measurement of Quantities: The quantities of work performed will be computed by the City on the basis of measurement taken by the City or its assistants, and these measurements shall be final and binding. All work computed under the Contract shall be measured by the City according to the United States Standard Measurement and Weights. The City does not assume any responsibility that the final quantities will remain in accord with estimated quantities, nor shall the Contractor claim misunderstanding or deception because of such estimate of quantities.

The estimated quantities of work to be done and material to be provided may be increased, decreased, or omitted, as provided herein. Any increase in quantities shall be approved by the City prior to any work.

3.1.39 Reference to Other Specifications: Where reference is made to specifications such as ASTM, AWWA or AASHTO, the latest edition shall be used.

3.1.40 Sanitary Facilities: The Contractor shall provide and maintain, in a sanitary condition, facilities for his/her employees as are required by local and state boards of health.

3.1.41 Quality of Equipment and Materials: To establish standards of quality, the City may, in the specifications, refer to products by name and/or catalog number. This procedure is not to be construed as eliminating from competition other products of equal quality by other manufacturers where fully suitable in design.

3.1.41.1 The Contractor shall furnish a complete list of proposed desired substitutions prior to signing of the Contract together with such engineering and catalog data as the City may require.

3.1.41.2 The Contractor shall abide by the City's judgment when proposed substitute items of equipment are judged unacceptable and shall furnish the specified item of equipment in such case. All proposals for substitutions shall be submitted in writing by the General Contractor. The City will approve or disapprove proposed substitutions in writing within a reasonable time.

3.1.42 Codes and Laws: The successful Bidder shall comply with all Federal, State, Local Laws and Ordinances that affect the Contract in any way.

3.1.43 Traffic Control: The Contractor shall comply with the National Committee on Uniform Traffic Control and Devices (NCUTCD) standards established by the Federal Highway Commission and the most current FDOT Standards for Traffic Control Through Work Zones and maintain safe conditions at all times.

3.1.44 Exploration and Reports: If reference is made to identification of reports of explorations and tests of subsurface, or other project specific, conditions at the site that have been used in preparing the Contract documents, it should be understood that these reports are not part of the Contract documents. The Contractor shall have full responsibility with respect to subsurface, or other project specific, conditions at the site. Technical data, made available only at the Contractor's request, may not be sufficient for construction purposes. Additional investigations may be necessary for the purposes of carrying out the construction project. If the Contractor desires additional subsurface, or other applicable project specific, investigation, it will be done at his/her expense, prior to bidding. Limited Subsurface, or other project specific, reports for this project are available through North Port Department of Public Works.

If the Contractor has elected not to make subsurface, or other project specific, investigation prior to bidding, he/she shall not be entitled to any extra compensation or Contract change orders due to conditions encountered.

3.1.45 Existing Structures: Drawing of physical conditions in or relating to existing surface and subsurface structures which are at or contiguous to the site that have been utilized by the consultant and/or the City in preparation of the Contract documents. The Contractor may rely upon the accuracy of the technical data contained in such drawing but not for the completeness thereof for the purpose of preparing or submitting a bid. Except as previously indicated, the Contractor shall have full responsibility with respect to physical conditions in or relating to such structures.

3.1.46 Report of Differing Conditions: If the Contractor believes that any technical data on which he/she relies is inaccurate, or if any physical conditions uncovered or revealed at the site differ materially from that indicated, reflected, or referred to in the Contract documents, the Contractor shall promptly, after becoming aware and before performing any work in connection therewith (except in emergency situations), notify the City in writing about the inaccuracy of difference. The City will promptly review the pertinent conditions, determine the necessity of obtaining additional explorations or tests with respect thereto and advise the City in writing (with a copy to the Contractor) of the City's findings and conclusion. Contractor's cost of, or the time required for, performance of any part of the work under this Contract, whether or not changed as a result of such conditions, an equitable adjustment shall be made and the Contract modified in writing accordingly.

No claim of the Contractor under this clause shall be allowed unless the Contractor has given the notice required: provided, however, the time prescribed therefore may be extended by the City.

No claim by the Contractor for an equitable adjustment hereunder shall be allowed if asserted after final payment under this Contract.

3.1.47 Not Shown or Indicated: If an underground facility is uncovered or revealed at or contiguous to the site, which was not shown or indicated and of which the Contractor could not reasonably have been expected to be aware, the Contractor shall promptly, before performing any work (except in emergencies), identify the owner of such underground facility and give written notice thereof to that owner and to the City. The Contractor will review the underground facility to determine the extent to which the documents should be

modified to reflect and substantiate the consequences of the existence of the underground facility. With City approval, the Contract documents will be amended or supplemented to the extent necessary. During such time, the Contractor shall be responsible for the safety and protection of such underground facility. The Contractor shall be allowed an increase or an extension of time, or both, to the extent that they are attributable.

3.1.48 Progress Meeting: Progress meetings will be conducted bi-weekly or as required if requested by Contractor or the City.

3.2 Storage of Materials

3.2.1 Contractor shall, at its expense, receive, unload, store in a secure place, and deliver from storage to the construction site all materials and equipment required for the performance of the Contract.

3.2.2 Contractor is not entitled to payment for same except for those materials which in City's discretion are properly stored and are going to be installed or incorporated into the construction of the Project within thirty (30) days of delivery to the construction site.

3.2.3 The storage facilities and methods of storing shall meet City's approval and shall be in accordance with manufacturer's recommendations, or City will not be obligated to pay for same.

3.2.4 Materials and equipment subject to degradation by outside exposure shall be stored in a weather tight enclosure provided by Contractor at its expense.

3.2.5 City may at its discretion require material to be stored in an air-conditioned location.

3.2.6 Provided the above conditions are met, the stored materials may be included in a subsequent

3.2.7 Application for Payment if the Contractor also complies with the following:

3.2.7.1 An applicable purchase order is provided listing the materials in detail and identifying the Contract Documents, by name, with verification that the total value of the purchase order amount reconciles with the corresponding application for payment stored materials line item value.

3.2.7.2 Evidence that proper storage security is provided.

3.2.7.3 The City is provided legal title (free of liens or encumbrances of any kind) to the material that is stored or stockpiled.

3.2.7.4 The Contractor and/or its Subcontractor have provided insurance for the Stored Materials against loss, damage (from whatever source), or disappearance, including loss or theft prior to incorporation into the Work. By execution of the Contract, Contractor releases City from any responsibility for Stored Materials and assumes all liability for and risk of loss or damage, by whatever means, including City's alleged negligence, regardless of whether the City has paid for said Stored Materials.

3.2.8 Once any Stored Material is paid for by City, it shall not be removed from the designated storage area except for incorporation into the Work or upon subsequent written approval by City.

3.2.9 No Applications for Payment shall be submitted nor payments made based on the value of materials stored at locations other than the Project, unless otherwise approved in writing by the City.

- 3.2.10** It is further agreed between the parties that the transfer of title and the City's payment for any Stored Material pursuant to the Contract Documents shall in no way relieve the Contractor of the responsibility for providing and installing such material in accordance with the requirements of the Contract Documents.
- 3.2.11** The Contractor warrants that title to all of the Work or Stored Materials covered by the Application for Payment will pass to the City either by incorporation in the Project or upon receipt of payment by the Contractor, whichever occurs first, free and clear of all liens, claims, security, interest or encumbrance: and that none of the Work and none of the Stored Materials covered by the Application for Payments will have been acquired by the Contractor, or by any other person performing the Work at the site or providing materials and equipment to the Project, subject to an agreement under which an interest therein or encumbrance thereon is retained by the seller or otherwise imposed by the Contractor or such person.
- 3.2.12** In the event stored materials which the City is paying for in advance of their being installed or incorporated into the Project pursuant to this Paragraph are not installed or incorporated into the Project within thirty (30) days of when they are delivered to the site, Contractor shall not be entitled to payment for any future stored materials on this Project and the amounts previously approved for payment for said materials shall be deducted from the Contractor's next application for payment.

END OF SECTION II

**SECTION III
SPECIAL PROVISIONS**

SP-01 INTENT:

Hurricane Ian caused severe erosion around the east side of Fixed Weir (FW) No.123 which is located on MacCaughey Waterway just south of Snover Waterway. The erosion has severely lowered the water level upstream of the FW No. 123 which is interconnected with Snover Waterway. A large segment of Snover Waterway and other interconnected waterways are experiencing lower than normal water levels. A map of the location is shown on the cover sheet of the bid plans and included as Exhibit 1.

It is the intent of the City of North Port (hereinafter referred to as "City") to secure the services of a professional, licensed, and qualified Contractor to repair the erosion by driving sheet piling, installing weir concrete cap, backfilling the eroded embankment and adding rip rap canal bank revetment. Vibration monitoring and dewatering activities will be required together with sod stabilization of disturbed areas. Exhibit 2 is the construction plans for the erosion repairs.

These specifications are intended to provide the information by which prospective bidders may understand the minimum requirements of the City of North Port relative to entering into a contract to furnish construction services for select City properties within the boundaries of the City of North Port.

SP-02 EQUIPMENT: The Contractor shall only use equipment, machines, or combination of machines that are in good and safe working condition. The equipment shall produce results that meet or exceed the Technical Specifications stated herein.

Equipment incapable of providing this will not be acceptable for use on this Project. The Contractor shall not use equipment which is unsafe or in need of repair. Work completed with equipment, which is not properly functioning, shall be deemed unacceptable.

SP-03 CONSTRUCTION SCHEDULE: The work will be substantially complete within **60 calendar days** with final completion within **30 calendar days** after attaining Substantial Completion as established by the City. The date for **Final Completion** of the Project shall be established as **90 calendar days after** Notice to Proceed. Substantial completion shall include at a minimum, the installation of sheet piling, filling of all eroded areas included canal slope embankment and installation of the rip rap revetment and geotextile fabric. The installation of the concrete cap on the weir and final sodding can be completed with project final completion.

The Contractor shall furnish copies of the Construction Schedule to the City when requested to perform the work as outlined in the Bid Form. The City will notify the Contractor of such as needed work and the Contractor will provide a Construction Schedule to the City within thirty (30) days of the City's notification. A project update meeting will be held bi-weekly, or as required during contract.

SP-04 PRE-CONSTRUCTION CONFERENCE: A Pre-Construction Conference will be held, at which time the Contractor shall submit the following for the City's approval or acceptance:

A telephone list specifying the name, address, office phone number and cell phone numbers of all subcontractors or suppliers to be used on this project. If the Contractor proposes to subcontract any survey work that may be required, the Contractor shall include the registration number of the surveyor. The telephone list shall also include emergency telephone numbers. The Contractor shall include a 24-hour emergency telephone for the City's use, which the Contractor shall update as necessary throughout the

project. The Contractor shall request, in writing, any changes in subcontractors or suppliers.

No change in subcontractors or suppliers shall be made without written consent and approval from the City.

- In addition to the telephone and facsimile numbers, the Contractor shall provide an e-mail address where emails can be sent. The e-mail address must be monitored at least daily and capable of transferring electronic files.
- The Contractor shall submit to the City a list of equipment the Contractor proposes to utilize on this project.
- The Contractor shall submit for City approval a paper copy and electronic copy of a Construction Schedule prepared using City approved software, and a Schedule of Progress Payment Requests.
- The Contractor shall also submit all other materials or mix designs, which will be used by the Contractor for this Contract.

Mobilization may not start until all submittals have been accepted by the City and/or City's Representative. Once approved, no changes will be allowed without the written approval of the City and/or the City's Representative.

The Contractor shall also provide, on a monthly basis, an update to the Construction Schedule reflecting changes made as a result of such reasons as weather, breakdowns, and unanticipated delays, as a means of better monitoring the project.

SP-05 PROGRESS MEETING: For this project, progress meetings shall be bi-weekly, or as requested by the Contractor or the City. The Contractor shall designate a representative to attend Progress Meetings held at the North Port Public Works 1100 N. Chamberlain Blvd. North Port, Florida. The Contractor shall submit, at each meeting, up-to-date schedule information, a written projected schedule for the next two weeks, written claims for additional compensation, written claims for weather days to extend the Contract, results of all testing and Value Engineering Proposals. The City will use the updated schedule information to monitor the Contractor's production rate. Upon written notice from the City, the Contractor shall dedicate additional resources to increase the production rate such that the Contractor will be back on schedule. Failure to comply with the approved Construction Schedule shall result in the Contractor being considered in default and subject to suspension of this Contract. Contractor may request progress meetings be on a different schedule than bi-weekly provided the City can confirm work is proceeding expeditiously. City may require a return to bi-weekly progress meetings at any time.

SP-06 COOPERATION WITH UTILITIES: The Contractor shall notify all utility owner(s) affected by the construction prior to beginning work. Any expense of utility repair or other damage due to Contractor's operations shall be borne by the Contractor. Protection of utilities shall be the responsibility of the Contractor, who shall provide adequate protection to maintain proper service.

NOTE: The Contractor is to include within his bid prices, the costs to protect, and/or support, all above ground, overhead and underground utilities, which may be in conflict with the construction of this proposed project.

Attention is called to the Florida Underground Facility Damage Prevention and Safety Act defined in Florida Statute. This act provides for a "One Call Toll Free" telephone number to be used by all parties doing excavation, demolition or other underground construction.

SP-07 CONTRACT TIME: The Contractor specifically agrees that it will commence operations within a mutually agreed upon time following notification by the City to commence work and that all work to be performed under the provisions of this Contract shall be completed not more than **90 calendar days after** Notice to Proceed; subject only to delays caused through no fault of the Contractor or acts of God. Time is of the essence in the performance of this Contract. The contract time includes up to seven (7) calendar days for City and/or City's Engineer of Record review

of each submittal and resubmittal. There shall be no extension of time provided for modification and corrections or re-submittals to address deficiencies therein identified during the review by the City and/or City's Engineer of Record.

The work will be substantially complete within 60 calendar days; with final completion within **30 calendar days** after attaining Substantial Completion as established by the City. City shall provide the Contractor with a listing of items to be corrected or completed (punch list) after Substantial Completion is issued. The punch list will identify the remaining items that must be addressed to the satisfaction of the City by the Contractor to meet his/her obligations under the Contract. The Contractor shall complete all items on the punch lists to the satisfaction of the City prior to submittal of the application for final payment.

All extensions to the Contract time for permitted delays shall be by Change Order and signed by the City.

SP-08 PROJECT COMPLETION: Project final completion shall be defined as "the stage in the progress of the Work where the Work is complete in accordance with the Contract Documents so that the City can begin to utilize the Work for its intended use, all punch list items are complete, and the Contractor has completely demobilized from the project area." Project final completion shall not be more than **90 calendar days**.

SP-09 LIQUIDATED DAMAGES: The work shall be completed within the contract time as required by SP-08 "PROJECT COMPLETION." The contract time shall include the preparation, submittal, review and approval of submittals, delivery of materials, and construction, assembly, adjustment and placement into service for beneficial use of all facilities covered under this Contract. The City of North Port shall issue a Notice of Completion when it has determined that the work identified in the contract has been completed per SP-08 "PROJECT COMPLETION."

The City and the Contractor hereby agree that time is of the essence on this Contract and the City will suffer damages if the work is not completed within the contract time as required by SP-07 "Contract Time". It is further recognized and agreed by the City and the Contractor that the determination of the exact value of the damages the City would suffer due to a delay in the Completion of the work would be a difficult, time consuming and costly process. It is therefore hereby agreed by the City and the Contractor that it is in their mutual interest to establish a figure **NINE HUNDRED AND EIGHTY DOLLARS (\$980.00)** as Liquidated Damages (but not as a penalty) to be paid by the Contractor to the City for each calendar day that Completion is delayed beyond the Contract Time. It is mutually agreed by the City and the Contractor that neither shall make any claim to increase or reduce the amount to be paid under Liquidated Damages as the result of any calculation of actual damages suffered by the City as the result of delay in the Completion of the work.

For all contracts, regardless of whether the contract time is stipulated in calendar days or working days, the City will count default days in calendar days. If the Contractor or, in case of his default, the surety fails to complete the work within the time stipulated in the Contract, or within such extra time that the City may have granted the Contractor or, in case of his default, the surety shall pay to the City, not as a penalty, but as liquidated damages, in the amount of **NINE HUNDRED AND EIGHTY DOLLARS \$980.00** per calendar day in which work is not completed.

The City has the right to apply, as payment on such liquidated damages, any money the City owes the Contractor.

The City does not waive its right to liquidated damages due under the Contract by allowing the Contractor to continue and finish the work, or any part of it, after the expiration of the Contract Time including granted time extensions.

In the case of default of the Contract and the completion of the work by the City, the Contractor and his surety are liable for the liquidated damages under the Contract, but the City will not charge liquidated damages for any delay in the final completion of the City's performance of the work due to any unreasonable action or delay on the part of the City.

The City considers the Contract complete when the Contractor has completed all work and the City has accepted the work. The City will then release the Contractor from further obligation except as set forth in his bond.

SP-10 DAMAGES: Areas adjacent to the construction that are damaged shall be repaired at the Contractor's expense. Restoration of adjoining areas shall be equal to or better than original condition and to the satisfaction of the City. Protection of personal property, utilities, structures, access drives, conduits, pavement, curbs, sidewalks, trees, and shrubs shall be the responsibility of the Contractor, who shall provide adequate protection to maintain proper service.

SP-11 CONTINUOUS PROSECUTION OF WORK: The Contractor shall continuously prosecute the work in accordance with the Contract Documents. Upon written direction from the City, the Contractor shall remove any personnel for the duration of the Contract, who fails to comply with the Contract Documents.

Once commencing the project, the operation must be continuously prosecuted during normal hours to its completion. At no time, shall the Contractor suspend work, for any reason for more than seven (7) calendar days, excluding delays granted for inclement weather. Should the Contractor fail to perform any work on the project for three (3) or more work days, the Contractor shall submit a written request to the City, no less than twenty-four (24) hours in advance of the restart of work, to allow the City to schedule the required inspection personnel. No work may restart, prior to the expiration of the twenty-four (24) hour notice without the City's approval.

Correction of safety concerns will be given priority and shall be corrected as soon as practicable, but not later than 24 hours after discovery by the City and notification to the Contractor. Failure to comply with these Provisions and/or Technical Specifications shall result in the Contractor being considered in default and subject to suspension of this contract.

SP-12 SAFETY AND PROTECTION:

- A. Contractor shall be responsible for initiating, maintaining, and supervising all safety precautions and programs in connection with the work. Contractor shall take all necessary precautions for the safety of and shall provide the necessary protection to prevent damage, injury or loss to:
 - i. All employees on the work and other persons or organizations who may be affected thereby.
 - ii. All the work and materials and equipment to be incorporated therein, whether in storage on or off the site.
- B. Other property at the site or adjacent thereto, including trees, shrubs, lawns, walks, pavements, roadways, structures, utilities, and underground facilities not designated for removal, relocation or replacement in the course of construction. Contractor shall comply with all applicable Laws and Regulations of any public body having jurisdiction for the safety of person or property or to protect them from damage, injury or loss; and shall erect and maintain all necessary safeguards for such safety and protection.
- C. All personnel working within the City's right-of-way shall at all times wear City approved safety vests, including personnel who may only briefly be out of their vehicle (i.e., supervisors, truck drivers).
- D. No open excavations are allowed on the project. Any pipe installation shall be backfilled properly the same day of work on such pipe area to allow safe passing of pedestrians and vehicles. The Contractor shall immediately remove any personnel who fail to conform to this requirement.
- E. Contractor shall designate a responsible representative at the site whose duty shall be the prevention of accidents. This person shall be the contractor's superintendent unless otherwise designated in writing by Contractor to City.

SP-13 CHANGES IN THE WORK: The City, without invalidating the Contract, may order extra work or make changes by altering, adding to or deducting from the work, the Contract sum being adjusted accordingly. Such work will be

an **amendment to the contract** and shall require approval by the City Manager prior to prosecution of the additional work. The change and amount of compensation must be agreed upon in writing in a document of equal dignity herewith prior to any deviation from the terms of this Contract. In giving instructions, the City shall have authority to make minor changes in the work, not involving extra cost, and not inconsistent with the purposes of the work. Except in an emergency endangering life or property, no extra work or change shall be made unless in pursuance of a written order by the City; and no claim for an addition to the Contract sum shall be valid, unless ordered.

Contingency: An amount added to an estimate to allow for items, conditions, or events for which the state, occurrence, or effect is uncertain and that experience shows will likely result, in aggregate, in additional costs. All contingency items will require approval from the Budget Administrator or designee, Purchasing Manager or designee, the Finance Director, Assistant City Manager and City Manager prior to any work being performed.

Value of any such extra work or change shall be determined in one or more of the following ways:

1. By estimate and acceptance in a lumpsum.
2. By unit prices named in the contract or subsequently agreed upon.
3. By cost and percentage or by cost and a fixed fee.
4. By Change order executed by CityManager
5. By Contingency Authorization (executed by City Manager).

If none of the previous methods are agreed upon, the Contractor, provided he receives an order as above, shall proceed with the work. In such case and also under case, he shall keep amendment in such form as the City may direct, a correct amount of the net cost of labor and materials, together with vouchers. The City shall certify to the amount, including reasonable allowance for overhead and profit, due to the Contractor. Pending final determination of value, no payment on changes shall be made.

SP-14 SUBCONTRACTING, SUBLETTING AND/OR ASSIGNMENT: Do not, sell, transfer, assign or otherwise dispose of the Contract or Contracts or any portion thereof, or of the right, title, or interest therein, without written consent of the City. If the Contractor chooses to sublet any portion of the Contract, the Contractor must provide a written request to sublet work to the City for approval. With the City's acceptance of the request, the Contractor may sublet a portion of the work, but shall perform with its own organization work amounting to **not less than 50%** of the total Contract amount. The request will be deemed acceptable by the City, for purposes of the City's consent, unless the City notifies the Contractor within five (5) business days of receipt of the request that the City is not consenting to the requested subletting.

Include in the total Contract amount the cost of materials and manufactured component products, and their transportation to the project site. For the purpose of meeting this requirement the City will not consider off-site commercial production of materials and manufactured component products that the Contractor purchases, or their transportation to the project, as subcontracted work.

If the Contractor sublets a part of a Contract item, the City will use only the sublet proportional cost in determining the percentage of subcontracted normal work. Execute all agreements to sublet work in writing and include all pertinent provisions and requirements of the Contract. All other agreements must be in writing and reference all applicable Contract provisions. Upon request, furnish the City with a copy of the subcontract and agreement. The subletting of work does not relieve the Contractor or the surety of their respective liabilities under the Contract.

The City recognizes a subcontractor only in the capacity of an employee or agent of the Contractor and the Engineer may require the Contractor to remove the subcontractor as in the case of an employee.

All sublets will be in continued compliance with all Contract provisions and the Contractor will continue to perform

the minimum percentage of Contract work with its own organization, as required by said Contract. It is recognized and agreed that the prime contractor remains responsible for the proper performance of all requirements of said contract and use of sublet does not relieve or release the Contractor and his surety or either of them of any liability under the contract bond. A false statement or omission made in connection with subletting is sufficient cause for suspension, revocation, or denial of qualification to bid, and a determination of non-responsibility, and may subject the person and/or entity making the false statement to any and all civil and criminal penalties available pursuant to applicable Federal and State Law.

SP-15 AVAILABILITY OF LANDS: Work is planned to occur within the City's right of way. Parcel number 0 0979-04-0321 on the east side of FW No. 123 will be available to the Contractor for use as a staging area during the duration of the project. Erosion repair will also be need on the adjacent parcel number 0979-04-0322 and the City will be securing a Right-of-Entry on this property for access. It is the Contractor's responsibility to ensure that any equipment or materials stored on the site is properly secured and presents no harm or impact to the public or surrounding parcels. The City is not responsible for theft, damage, injury, or other losses incurred by the use of this staging area. The parcel and all City right of way must be restored to its original condition, or better, upon project completion.

SP-16 COORDINATION OF THE SPECIFICATIONS: Where conflicts between the City of North Port General Provisions, Special Provisions, Technical Specifications and Construction Plans, references, should they exist, it is the responsibility of the bidding Contractor to bring those conflicts to the attention of the Purchasing Agent prior to the bid date. After bids, have been received, the contractor will be held to the most stringent requirement.

The Contractor shall take no advantage of any apparent error or omission in the plans or specifications. If the Contractor discovers such an error or omission, he shall immediately notify the City. The City will then make such corrections and interpretations as may be deemed necessary for fulfilling the intent of the plans and specifications.

SP-17 CONSTRUCTION PERMITS: This work is considered as maintenance repair as a result of the impact of Hurricane Ian, and no State or Federal authorization is needed.

SP-18 NOTICE-OF-INTENT (NOI): As the areas of disturbance is less than 1 acre, a Notice of Intent to Use Generic Permit for Stormwater Discharge from Large and Small Construction Activities from Florida Department of Environmental Protection is not needed. However, the Contractor shall still adhere to the best management practice show on the construction plans. When directed by City site inspector, turbidity monitoring shall be included to show construction activities will not increase the turbidity in the receiving waterway by more than 29 NTU above background levels.

SP-19 SPECIFICATIONS AND PLANS: Information regarding this project may be viewed and downloaded from DemandStar's website at www.demandstar.com. Links to DemandStar are also available from the city website at www.northportfl.gov. Bid documents are posted on the City FTP site at <https://www.cityofnorth.com/filesshare>.

SP-20 CONTRACTOR'S UNDERSTANDING: It is understood and agreed that the Contractor has, by careful examination, satisfied himself as to the nature and locations of the work, the conformation of the ground, the character, quality, and quantity of materials to be encountered, the character of equipment and facilities needed prior to and during prosecution of the work under this Contract. No verbal agreement or conversation with any officer, agent, or employee of the City, either before or after execution of this Contract, shall affect or modify the terms or obligations herein contained.

SP-21 ERRORS OR OMISSIONS IN PERMITS, PLANS OR SPECIFICATIONS: The Bidder shall take no advantage of any apparent error or omission, which may be discovered in the Permits, Plans or Specifications but shall forthwith notify the City Representative of such discovery, who will then make such correction and interpretations as deemed

necessary for reflecting the actual spirit and intent of the Permits and Specifications.

SP-22 ROAD/LANE CLOSURE: No road closures are allowed. A lane closure request must be submitted in writing five (5) business days in advance of the requested lane closure. The time and length of closure(s) shall be approved by the City of North Port. The Contractor shall provide a Maintenance of Traffic (MOT) Plan for the requested lane closure(s) for review and approval by the City of North Port.

SP-23 MAINTENANCE OF TRAFFIC: The contractor shall be responsible for all maintenance of traffic and obtaining approval of a Maintenance of Traffic (MOT) Plan from the City for work within the ROW of any City Road. The Contractor shall maintain traffic at all times during construction.

SP-24 DEWATERING: The Contractor shall submit a dewatering plan for approval from the City of North Port Project Manager before starting dewatering.

SP-25 PRIVATE PROPERTY: The Contractor shall not occupy private land outside of any easements or rights of way unless a written authorization has been signed by the property owner. It shall be the Contractor's responsibility to obtain these agreements prior to construction, if required. Prior to the use of private lands, the Contractor shall submit a copy of the agreement(s) to the City. In the event that the Contractor uses private property for any purpose without first having obtained the necessary approvals from the property owner or provided the necessary agreement to the City, the City will direct the Contractor in writing to immediately cease using such property.

Prior to application for final payment, the Contractor shall provide documentation from the owner of each piece of private property for which an agreement for use was provided, or for which the City has issued written notification to the Contractor, that each owner is satisfied with the manner in which the Contractor has restored the property. Final payment or reduction in retainage shall not be paid until such documentation is received by the City.

Any areas, outside of the rights-of-way or easements that are impacted or damaged by the Contractor's activities shall be repaired at the Contractor's expense to the property owner's satisfaction. Restoration of impacted areas shall be equal to or better than original condition and to the satisfaction of the property owner. Reasonable effort shall be made to replace damaged property to a style and quality as similar as possible to the original property. The Contractor shall be responsible to secure written approval of the restoration of the property from the property owner and submitting a copy to the City prior to requesting Substantial Completion. The City shall not release retainage to the Contractor until such time as the approvals are submitted by the Contractor.

SP-26 RESIDENTS CONCERNS: During the work of this Contract, residents may contact the City to question the progress of the work or express concerns regarding the work. These concerns are responded to by the City's Public Works Department, but normally the Contractor will have more detailed information on the actual scheduling of the work or corrective measures required. Therefore, the Contractor will provide a telephone number and email address where the City's Public Works Department can fax or email inquiries.

The Contractor shall respond to these inquiries within two (2) business days detailing how the inquiry will be addressed and the time frame the Contractor will take in addressing this inquiry. City's Public Works Department will maintain a log of inquiries, which will be reviewed at each progress meeting.

SP-27 TESTING: Any and all testing requirements born out of, but not limited to contract requirements and permits, for the work described in the plans will be included in the Contractor's bid price. Testing will be arranged in advance with an independent testing firm (also included in the bid price) for the testing of concrete for the concrete cap and compaction of the restored area. The City requests to be notified three (3) business days in advance of any test in order to have a City representative and the Engineer of Record, if required, present. Where less time for notice is specified in the specifications or plans, this special provision shall prevail.

SP-28 MISCELLANEOUS ITEMS: Miscellaneous items and accessories which are not specifically mentioned, but which are essential to produce a complete and properly operating installation, or usable structure or plant, providing the indicated function, shall be furnished and installed without change in the Contract Price. Such miscellaneous items and accessories shall be of the same quality standards, including material, style, finish, strength, class, weight and other applicable characteristics, as specified for the major component of which the miscellaneous items or accessory is an essential part, and shall be approved by the City's Engineer of Record before installation. The above requirement is not intended to include major components not covered by or inferable from the Drawings and Specifications.

SP-29 SOURCES OF WATER FOR TESTING, CLEANING, AND OTHER CONSTRUCTION PURPOSES:

If potable water is required for the Work of this Contract, all Contractors' connection(s) to the City potable water supply shall allow the City to meter the amount of water used. All potable water connections shall include a reduced pressure zone backflow preventer. The Contractor is responsible for obtaining meter(s), backflow preventers, and associated appurtenances, and paying all appropriate fees/deposits. Contractor shall not use any potable water until meter and backflow preventer are installed. The Contractor will set up an account with the City and will be billed at the City's normal rates for actual potable water used. Any fees/deposits due back to the Contractor will be returned after the project is completed and the meter is removed.

SP-30 VIBRATION MONITORING: The Contractor shall be required to comply with Section 455-1 of FDOT Standard Specifications (FY2023-24). Existing structures shall be protected per Section 455-1.1 which references Section 108. The Contractor will be required to submit the pre-construction survey and vibration control plan for approval prior to sheet pile installation. A minimum of two vibration monitoring locations at the two nearest properties – 3386 Tuskett Ave and 3606 Slayton Ave shall be conducted during all sheet pile driving activities. The costs associated with complying with Section 455-1 and Section 108-2.2 shall be included in the bid price for the steel sheet pile.

SP-31 PRE-CONSTRUCTION SURVEY: No construction shall take place prior to the City's acceptance of the Pre-Construction Video and Survey. Photos and Video shall thoroughly capture the intended work area as well as nearby properties as outlined in the Contract Documents and the Vibration Monitoring Plan (See SP-30 "VIBRATION MONTIORING"). The Pre-Construction Survey should include a thorough inspection and photo/video documentation of the existing structures, including pools, patios, driveways, houses, fences, and sheds on the two nearest properties – 3386 Tuskett Ave and 3606 Slayton Ave. The Pre-Construction Photos and Video will be used to protect all parties involved in the project.

SP-32 PERIODIC CLEAN UP AND RESTORATION: During construction, the Contractor shall regularly remove from site and properly dispose of all accumulated debris and surplus material of any kind that result from their operations. The Contractor shall remove unsightly mounds of earth, large stones, boulders, and debris so the site presents a neat appearance. Burial of construction debris is not permitted. Unused tools and equipment shall be stored at the Contractor's yard or base of operations for the project. When the contract work involves ROWs, private property, roadways, private driveways or access roads, easements and sidewalks, and any site work that may impede pedestrian or vehicular traffic while the installation work is in progress, the Contractor shall backfill, grade, compact, and otherwise restore the area to the basic condition which existed prior to work in order to allow vehicular and pedestrian use. All areas should be restored to their original design grade to facilitate drainage.

SP-33 CITY RIGHT-OF-WAY RESTORATION: The ROW restoration includes all procedures to restore the ROW to a condition equal to or better than the original condition to the satisfaction of the City. The Contractor shall be responsible for restoration of items including but not limited to existing structures, stabilized roads, and ground areas damaged during construction.

SP-34 LABOR, MATERIALS AND EQUIPMENT: The Contractor will provide competent, suitably qualified personnel to survey and lay out the Work and perform construction as required by the Contract Documents. He will at all times

maintain good discipline and order at the site.

The Contractor will furnish all materials, equipment, labor, transportation, construction equipment and machinery, tools, appliances, fuel, power, light, heat, local telephone, water and sanitary facilities and all other facilities and incidentals necessary for the execution, testing, initial operation and completion of the Work.

All materials and equipment will be new, except as otherwise provided in the Contract Documents. When special makes or grades of material which are normally packaged by the supplier or manufacturer are specified or approved, such materials shall be delivered to the site in their original packages or container with seals unbroken and labels intact.

All materials and equipment shall be applied, installed, connected, erected, used, cleaned and conditioned in accordance with the instructions of the applicable manufacturer, fabricator or processors, except as otherwise provided in the Contract Documents.

SP-35 MATERIALS, EQUIPMENT, PRODUCTS, AND SUBSTITUTIONS: Materials, equipment and products incorporated in the Work must be approved for use before being purchased by the Contractor. The Contractor shall submit to the City a list of proposed materials, equipment or products, together with such samples as may be necessary of him to determine their acceptability and obtain his approval. No request for payment for "or equal" equipment will be approved until this list has been received and approved by the City.

Whenever a material, article or piece of equipment is identified on the Drawings or Specifications by reference to brand name or catalog number, it shall be understood that this is referenced for the purpose of defining the performance or other salient requirements and that other products of equal capacities, quality and function shall be considered per 40 CFR 33.255(c) as referenced in Chapter 62-552, FAC. The Contractor may recommend the substitution of a material, article, or piece of equipment of equal substance and function for those referred to in the Contract Documents by reference to brand name or catalog number, and if, in the opinion of the City, such material, article, or piece of equipment is of equal substance and function to that specified, the City may approve its substitution and use by the Contractor. Incidental changes or extra component parts required to accommodate the substitute will be made by the Contractor without a change in the Contract Price or Contract Time.

No substitute shall be ordered or installed without the written approval of the City who shall be the judge of equality. Delay caused by obtaining approvals for substitute materials will not be considered justifiable grounds for an extension of construction time.

Should any work or materials, equipment or products not conform with requirements of the Drawings and Specifications or become damaged during the progress of the Work, such Work or materials shall be removed and replaced, together with any work disarranged by such alteration, at any time before completion and acceptance of the Project. All such work shall be done at the expense of the Contractor.

No materials or supplies for the Work shall be purchased by the Contractor or by any Subcontractor subject to any chattel mortgage or under a conditional sale or other agreement by which an interest is retained by the Seller. The Contractor warrants that he has good title to all materials and supplies used by him in the Work.

SP-36 USE OF PREMISES: The Contractor shall confine his apparatus, storage of materials, and operations of his workmen to limits indicated by law, ordinances, permits, and directions of City, and shall not unnecessarily encumber any part of the site.

Contractor shall not overload or permit any part of any structure to be loaded with such weight as will endanger its

safety, nor shall he subject any part of the Work to stresses or pressures that will endanger it.

Contractor shall enforce City's instructions in connection with signs, advertisements, fires and smoking.

Contractor shall arrange and cooperate with City in routing and parking of automobiles of his employees, Subcontractors and other personnel, and in routing material delivery truck and other vehicles to the Project site.

SP-37 SURVEY: All survey monuments and benchmarks that may be disturbed during construction shall be referenced and replaced by the Contractor. All monuments and benchmarks disturbed or destroyed by the Contractor or any of his forces through accident or negligence shall be replaced by a Florida Licensed Professional Land Surveyor at the Contractor's expense.

SP-38 MANUFACTURER'S LITERATURE: Manufacturer's literature, when referenced, shall be dated and numbered and is intended to establish the minimum requirements acceptable. Whenever reference is given to codes, or standard specifications or other data published by regulating agencies or accepted organizations, including but not limited to National Electrical Code, applicable State Building Code, Federal Specifications, ASTM Specifications, various institute specifications, and the like, it shall be understood that such reference is to the latest edition including addenda in effect on the date of Bid.

SP-39 BRAND NAMES: Brand names where used in the technical specifications, are intended to denote the standard of quality and performance required of the particular material or product. The term "equal" or "equivalent", when used in connection with brand names, shall be interpreted to mean a material or product that is similar and equal in type, quality, size, capacity, composition, finish, color and other applicable characteristics to the material or product specified by trade name, and that is suitable for the same use and capable of performing the same function, in the opinion of the City's Engineer of Record, as the material or product so specified. The City's Engineer of Record must approve proposed equal items before they are purchased or incorporated in the Work.

SP-40 AS-BUILT DRAWINGS: The Contractor will keep one copy of all Specifications, Drawings, Addenda, Modifications, and Shop Drawings at the site in good order and annotated to show all changes made during the construction process. As-built drawing should show at a minimum the length and depth of the new sheet piling installed and the dimensions of the concrete cap and the extent of the rip rap bedding stone and geotextile installed. Drawings shall be supplied to the City prior to application for final payment in the form a PDF signed by the contractor and AutoCAD formatted document(s).

SP-41 COMPLETION OF THE PROJECT: The Completion of the project shall be accomplished and finalized prior to submittal of the application for final payment by the Contractor. The City shall determine the date of completion for the project when at the minimum, the following are met as well as all other conditions defined in the Contract Documents:

- All punch list items have been addressed to the satisfaction of the City;
- All testing has been completed and results are satisfactory;
- Record Drawing requirements have been accepted and approved by the City and all other governmental agencies, if applicable;
- All associated equipment and facilities necessary for the reliable operation of the project are complete in accordance with contract requirements; and,
- All release of liens has been submitted and are satisfactory to the City, certifying that all payrolls, material bills, and other indebtedness incurred by the Contractor in connection with this project have been paid in full.

SP-42 STORED MATERIALS: Payment for stored materials will be made in accordance with Section 3.2 of the General Provisions.

SP-43 PAYMENT ADJUSTMENT: The following will apply: This Contract will *not* provide for fuel or other payment adjustments due to increase in material costs during the life of the contract.

SP-44 TERMINOLOGY: Throughout the Contract Documents, references to City or Owner shall, where appropriate, refer to the City of North Port, a municipal corporation of the State of Florida. References to Public Works refer to the City of North Port's Public Works Department. References to Engineer refer to the City's Engineer.

The terms General Conditions and General Provisions are used interchangeably in the Contract Documents. The terms Special Conditions and Special Provisions are used interchangeably in the Contract Documents.

The term "Contract Documents" is used interchangeably with "Agreement."

SP-45 WORK HOURS: The Contractor shall conduct work between 7 A.M. and 5:00 P.M. Monday through Friday, which is defined as regular work hours. The Contractor shall not conduct work on Saturdays, Sundays, legal holidays or holidays observed by the City. Work conducted outside of the regular work hours and days shall be permitted only with written permission from the City. Any additional cost incurred by North Port Staff and/or the Engineer of Record for work outside these hours will be paid by the Contractor.

SP-46 NOTIFICATIONS OF 48 HOURS: Wherever the technical specifications or plans indicate a minimum of 48 hours' notice to Owner/City or Engineer, this special provision shall prevail dictating a minimum of three (3) business days' notice to Owner/City or Engineer.

SP-47 QUALIFICATIONS/REFERENCES: Contractor shall submit a minimum of two (2) **references** of projects of similar size and scope (within the past fifteen (15) years).

- Each reference shall include a project description, project location, name and phone number of a contact person, total project amount, and completion date.

The City reserves the right to contact references. Bidder is referred to MINIMUM QUALIFICATIONS AND REFERENCE FORM included later herein. Please provide accurate telephone and e-mail address for contact person.

SP-48 LICENSE(S) REQUIREMENT: Certified General Contractor

SP-49 CITY'S STATUS: The City shall examine and inspect the work to assure compliance with the requirements of the Contract Documents. The City shall determine the quality and acceptability of materials and workmanship relative to the requirements of the Plans and Technical Specifications. The City has the authority as follows:

1. To stop the work whenever such stoppage may be necessary to insure the proper execution of the Contract.
2. To reject all work which does not conform to the Contract.
3. To resolve questions which arise in the execution of the work.
4. To stop work whenever materials or shop drawings have not been approved prior to placement.

No additional time or compensation will be added to the Contract when stopping the work for the above listed reasons.

SP-50 FEDERAL FUNDING: The projects, programs, and activities to be funded under this Agreement are fully or partially funded by Federal funding, grants and disaster assistance from various federal and state agencies including the Florida Division of Emergency Management (FDEM) and the Federal Emergency Management Agency (FEMA). Therefore, consultants, contractors and their subcontractors (hereinafter referred to as "Contractor") will be required to comply with the following provisions, as applicable. The Contractor shall require compliance with all applicable federal requirements listed below of all subcontractors performing work, by including these federal requirements in all contracts with subcontractors.

The attachments and supplemental documents are attached and incorporated fully as part of this solicitation and followed by Contract.

The City has the right to incorporate any and all additional attachments and supplemental terms and conditions, and as amended by the Federal Emergency Management Agency (FEMA).

The bidder shall complete, notarize, certify and execute all the attachments provided in this solicitation and include with submittal.

SP-51 CRITERIA FOR AWARD: The award of this bid shall be to the lowest responsive, responsible bidder in whole or in part whichever is determined to be in the best interest of the City, meeting the requirements of the specifications and provisions set forth herein. Other consideration(s) of award shall be references, and equipment list. Any unfavorable references may be cause to deem bidder non-responsive.

The City reserves the right to reject the bid proposal of any bidder who has previously failed to perform properly, or on time, contracts of similar nature; or who is not in a position to satisfactorily perform the contract.

TECHNICAL SPECIFICATIONS

TS-01 STEEL SHEET PILING

The new steel sheet piling shall be PZC-18 ASTM A-572 Grade 50. Provide shop drawings for City approval. Contractor to provide detail on connection between existing structure and the new sheet piling and concrete cap for City approval. Connection needs to be watertight.

TS-02 CONCRETE CAP

Provide shop drawings for City approval for the concrete cap to the weir.

A commercial testing laboratory will be required to perform the following concrete test:

1. Samples for strength tests of each class of concrete placed each day shall be taken not less than each concrete pour event, nor less than every 50 cy of concrete placed.
2. Conduct strength tests for concrete according to the following procedures.
 - a. Secure samples according to ASTM C172.
 - b. Mold five specimens from each sample according to ASTM C31. Cure under standard moisture and temperature conditions as specified in ASTM C31.
 - c. Test one specimen at 3 days, one at 7 days and two at 28 days according to ASTM C39. If one or both of the 28-day tests indicate a compressive strength below required strength of 3500psi , the fifth specimen shall be tested at 56 days. If all tests indicate a compressive strength below the strength required, the ENGINEER may direct the CONTRACTOR to perform testing of in-place concrete at no additional cost to the OWNER, regardless of the outcome of the tests.
3. All concrete test results shall be provided to the City Project Manager as soon as available

TS-03 RIP RAP, BEDDING STONE AND GEOTEXTILE FABRIC

Provide shop drawings for City approval for the following:

1. The rip-rap (Bank and Shore Protection) shall be per FDOT Standard Specifications for Road and Bridge Construction, FY 2023-24, Section 530-2.1.3.1. Provide a minimum thickness of 2.5 feet with a minimum specific gravity of 2.2 and shall meet the gradation and thickness requirements set forth in Section 530-2.1.3.1.
2. A 1-foot minimum thick layer of bedding stone under the rip-rap shall be per FDOT Standard Specifications for Road and Bridge Construction, FY 2023-24, Section 530-2.2.4.
3. Geotextile filter fabric shall be type D-2 geotextile type, as specified in the FDOT Standard Specifications for Road and Bridge Construction, FY 2023-24, Section 514 and 985.

**ATTACHMENT A
BIDDER CHECKLIST
(INCLUDE THIS LIST W/SUBMITTAL)
ATTACHMENTS TO BE COMPLETED AND RETURNED WITH BID**

Check (v) CITY REQUIRED FORMS FOR THIS PROJECT:

- ATTACHMENT A: Bidder Checklist
- ATTACHMENT B: Sealed Bid Label (if not using, please make sure all information is provided on envelope as per label)
- ATTACHMENT C: Excel Tabulation Price Sheet (Separate Attachment)
 - **(Must complete, PRINT and Submit with hard copy and on USB DRIVE).**
 - **DO NOT RECREATE THIS FORM. Do not pdf the spreadsheet**
- ATTACHMENT D: Bid Form
- ATTACHMENT E: Statement of Organization
- ATTACHMENT F: Addenda Acknowledgement and Bond Form Terms
- ATTACHMENT G: BID BOND FORM (CITY CREATED, DO NOT RECREATE AND ONLY USE THIS FORM)
- ATTACHMENT H: Equipment and Source of Supply/Subcontractor List
- ATTACHMENT I: Qualifications and References

Check (v) THE FOLLOWING CITY/FEDERAL ATTACHMENTS AND SUPPLEMENTS ARE APPLICABLE FOR THIS PROJECT:

- ATTACHMENT 1.1: Insurance
- ATTACHMENT 1.2: Professional Liability
- ATTACHMENT 1.3: Environmental and Pollution Liability
- ATTACHMENT 1.4: Builder's Risk
- ATTACHMENT 2.1: Indemnity Terms - General
- ATTACHMENT 2.2: Indemnification – Construction
- ATTACHMENT 3: FEMA Provisions
- ATTACHMENT 4: Davis Bacon – Min Wage Rate
- ATTACHMENT 5: Certification Regarding Lobbying

- ___(v)___ ATTACHMENT 6: Non-Collusive Affidavit
- ___(v)___ ATTACHMENT 7: Conflict of Interest Form
- ___(v)___ ATTACHMENT 8: Public Entity Crime Information
- ___(v)___ ATTACHMENT 9: Drug-Free Workplace Form
- ___(v)___ ATTACHMENT 10: The Florida Trench Safety Act
- ___(v)___ ATTACHMENT 11: Scrutinized Company Certification Form
- ___(v)___ ATTACHMENT 12: Vendor’s Certification For E-Verify System
- ___(v)___ ATTACHMENT 13: Performance and Payment Bond Terms
- ___(v)___ ATTACHMENT 14: Performance and Payment Bond Requirements and Form
- ___(v)___ ATTACHMENT 15: Debarment Form
- ___(v)___ ATTACHMENT 16: Contract Changes
- ___(v)___ ATTACHMENT 17: Sanctions and Penalties
- ___(v)___ ATTACHMENT 18: Termination for Convenience

BIDDER STATEMENT:

We understand the requirements requested and agree to fully comply with each of the Items identified IN **ATTACHMENT “A THROUGH I” AND ATTACHMENTS “1 THROUGH 18”**.

Date: _____

Signed (*Person authorized to bind the company*): _____

Name (printed): _____ Title: _____

THIS PAGE MUST BE COMPLETED AND SUBMITTED

**ATTACHMENT B
SEALED RFB ENVELOPE LABEL**

PLEASE NOTE: Courier Packages (Fedex, UPS, etc.) shall be clearly marked.

If not using label provided below, please include the following on the outside envelope: COMPANY NAME, RFB #, RFB TITLE, DATE DUE, TIME DUE, SUBMITTED BY, NAME OF COMPANY, E-MAIL ADDRESS, TELEPHONE.

Cut along the outer border and affix this label to your sealed solicitation envelope to identify it as a “Sealed RFB”.

PLEASE PRINT CLEARLY

SEALED RFB DOCUMENTS – DO NOT OPEN	
RFB #: _____	
RFB TITLE: _____	
DATE DUE: _____	
TIME DUE: _____	
SUBMITTED BY: _____	
(Name of Company)	
_____	_____
e-mail address	Telephone
Deliver to:	
City of North Port Finance Department - Purchasing Division Alla V. Skipper, CPPB, Senior Contract Administrator 4970 City Hall, 3 RD Floor, Suite 337 North Port, Florida 34286 RFB NO. 2023-23 HURRICANE IAN PERMANENT REPAIRS FOR FIXED WEIR (FW) NO. 123 EROSION REPAIRS	

Note: Submissions received after the time and date stated on the Notice of Availability will not be accepted.

ATTACHMENT C:

BID SCHEDULE IN EXCEL FORMAT

SEPARATE ATTACHMENT

- DO NOT RECREATE
- PRINT AND SUBMIT AN (1) ORIGINAL AND (1) HARD COPY
- SUBMIT ON USB DRIVE: DO NOT SAVE AS A PDF LEAVE IN EXCEL FORMAT

It is understood that the estimated summary of pay item quantities are approximate only and are solely for the purpose of facilitating the comparison of bids, and that the Contractor's compensation shall be computed upon the basis of the actual quantities in the completed work, whether they be more or less than those shown.

Preparation of Bid Schedules: Contractor MUST use the City provided excel spreadsheet. DO NOT RECREATE FORM.

All GREEN spaces in the Bid Form to be filled. Bidder should not reference the words "No Charge, N/A, included, dash, etc." in any of the spaces. Bidder must identify a monetary amount for each UNIT COST (unless the unit price is "x" out by the City). UNIT COST prevails over EXTENDED COST. Failure to identify a monetary amount in any of the UNIT COST line items shall cause Bidder to be deemed non-responsive and bid response be rejected. In case of discrepancy between unit price and extended price, the unit price will govern. Apparent errors in extension will be corrected.

**ATTACHMENT D:
BID FORM**

Company Name: _____

Business Address: _____

To the City Commission of the City of North Port pursuant to and in compliance with your notice inviting sealed bids (Invitation to Bid), Instructions to Bidders, and the other documents relating thereto, the undersigned Bidder, having familiarized himself/herself with the terms of the Contract documents, local conditions affecting the performance of the Contract, and the cost of the work at the place where the work is to be done, hereby proposes and agrees to perform within the time stipulated in the Contract, including all of its component parts and everything required to be performed, and to provide and furnish any and all of the labor, material, tools, expendable equipment, and all utility and transportation services and design of certain items necessary to perform the Contract and complete in a workmanlike manner, all of the work required in connection with the construction of said work all in strict conformity with the plans and specifications and other Contract documents for the prices hereinafter set forth.

The undersigned, as Bidder, does hereby declare that he has read the Request for Bids, Instructions to Bidders, General Provisions, Special Provisions, Supplemental Provisions, Technical Specifications & Conditions, Federal-FEMA Provisions and Attachments, Insurance Requirements, Bid Form, Permit Fees, Plan Revisions, Plans, and any other reports or documentation for: **RFB NO. 2023-23 Hurricane Ian Permanent Repairs for Fixed Weir (FW) No. 123 Erosion Repairs** and further agrees to furnish all items listed on the attached Bid Form in accordance with the unit price line items as indicated on the bid schedule form(s) submitted. The above specified documents are herein incorporated into the Bid Form.

The undersigned as Bidder, declares that the only persons or parties interested in this submittal as principals are those named herein: that this submittal is made without collusion with any person, firm, or corporation: and he/she proposes and agrees, if the proposal is accepted, that he/she will execute a Contract with the City in the form set forth in the Contract documents and that he/she will accept in full payment thereof the following prices, to wit:

PROJECT TOTAL:
_____ \$ _____

Through the signing of this Bid Form, Bidder attests his/her bid is guaranteed for a period of not less than **NINETY (90) DAYS** from the date of the official bid opening.

Date: _____

Signed (*Person authorized to bind the company*): _____

Name (printed): _____ Title: _____

THIS PAGE MUST BE COMPLETED AND SUBMITTED

**ATTACHMENT E:
STATEMENT OF ORGANIZATION**

The following information will be provided to the City of North Port for incorporation in legal documents. It is, therefore, vital all information is accurate and complete. Please be certain all spelling, and capitalization is exactly as registered with the state or federal government.

Company Name _____

Telephone # _____ **E-Mail** _____ **Fax #** _____

Main Office Address _____

City _____ **State** _____ **Zip Code** _____

Address of Office Servicing City of North Port, if different than above: SAME AS ABOVE

Office Address _____

City _____ **State** _____ **Zip Code** _____

Telephone # _____ **E-mail** _____ **Fax #** _____

Name & Title of Firm Representative _____

Federal Identification Number: _____

Bidder shall submit proof that it is authorized to do business in the State of Florida unless registration is not required by law.

(Please Check One)

Is this a Florida Corporation: Yes or No

If not a Florida Corporation,

In what state was it created: _____

Name as spelled in that State: _____

What kind of corporation is it: "For Profit" or "Not for Profit"

Is it in good standing: Yes or No

Authorized to transact business in Florida: Yes or No

State of Florida Department of State Certificate of Authority Document No.: _____

Does it use a registered fictitious name: Yes or No

Names of Officers:

President: _____ **Secretary:** _____

Vice President: _____ **Treasurer:** _____

Director: _____ **Director:** _____

Other: _____ **Other:** _____

Name of Corporation (As used in Florida):

(Spelled exactly as it is registered with the state or federal government)

Corporate Address:

Post Office Box: _____
City, State Zip: _____
Street Address: _____
City, State, Zip: _____

STATE OF _____

COUNTY OF _____

Sworn to (or affirmed) and subscribed before me by means of physical presence or online notarization, this ___ day of _____ 2023, by _____.

Notary Public – State of Florida

Personally Known _____ OR Produced Identification _____

Type of Identification Produced _____

Date: _____

Signed (Person authorized to bind the company): _____

Name (printed): _____ Title: _____

THIS PAGE MUST BE COMPLETED AND SUBMITTED

ATTACHMENT F:

ADDENDA ACKNOWLEDGEMENT

The undersigned acknowledges receipt of the following addenda, and the cost, if any, of such revisions has been included in the bid price.

Addendum No.		Dated		Addendum No.		Dated	
Addendum No.		Dated		Addendum No.		Dated	
Addendum No.		Dated		Addendum No.		Dated	
Addendum No.		Dated		Addendum No.		Dated	

BID BOND TERMS
(SEE FORM NEXT PAGE)

BID BOND: ACCOMPANYING THIS PROPOSAL IS _____
(insert: “cash”, “Bidder’s bond”, or “certified check”, as the case may be) in an amount equal to at least 5% of the total amount of the bid, payable to the City of North Port. Cashier’s checks will be returned to all Bidders after award of bid. If supplying a bid bond please use the attached bid bond form. **Note: Failure to submit a bid bond will be cause for rejection of bid.**

The undersigned deposits the above-named security as a proposal guarantee and agrees that it shall be forfeited to the City as liquidated damages in case this proposal is accepted by the City and the undersigned fails to execute a Contract with the City as specified in the Contract documents accompanied by the required labor and material and faithful performance bonds with sureties satisfactory to the City, and accompanied by the required certificates of insurance coverage. Should the City be required to engage the services of an attorney in connection with the enforcement of this bid, Bidder promises to pay City’s reasonable attorneys’ fees incurred with or without suit.

The undersigned agrees, if awarded this bid, to furnish a **PERFORMANCE AND PAYMENT BOND** in the amount of 100% of the total project price within ten (10) calendar days after notification of award to the Purchasing Department. The undersigned shall be responsible and bear all costs associated to record Performance and Payment Bond with Sarasota County Clerk’s Office. Receipt of said recording and a certified copy of the Bond shall be furnished to the Purchasing Division at the time of the pre-construction meeting.

All Contract documents (i.e.: performance and payment bond, cashier’s check, bid bond) shall be in the name of “City of North Port”.

Date: _____

Signed (Person authorized to bind the company): _____

Name (printed): _____ Title: _____

THIS PAGE MUST BE COMPLETED AND SUBMITTED

ATTACHMENT G

CITY OF NORTH PORT

BID BOND

In Compliance with F.S. Chapter 255.051

STATE OF FLORIDA, CITY OF NORTH PORT

KNOW ALL BY THESE PRESENTS, that _____, authorized by law to do business as a Contractor in the State of Florida, as Principal, and _____, a Corporation chartered and existing under the laws of the State of _____, as Surety, with its principal offices in the City of _____, and authorized to do business in the State of Florida, and in accordance with Section 255.051, Florida Statutes, are held and firmly bound unto the City of North Port, Florida, in the full and just sum of 5% of the Total Bid Price, in good and lawful money of the United States of America, to be paid upon demand by the City of North Port, to which payment well and truly to be made, we bind ourselves, our heirs, executors, administrators, and assigns, joint and severally and firmly by these presents.

The condition of the obligation is such, that whereas the Principal has submitted the attached Bid, dated _____, for **(RFB NO. 2023-23 FIXED WEIR (FW) NO. 123 EROSION REPAIRS)**.

NOW, THEREFORE, if the Principal shall withdraw said bid prior to the date of opening the same, or shall within 10 days after the prescribed forms are presented to him for signature enter into a written Contract with City of North Port, Florida, in accordance with the bid as accepted and give a Performance and Payment Bond with good and sufficient surety or sureties as may be required for the faithful performance and proper fulfillment of such Contract and for the prompt payment of all persons furnishing labor or materials in connection therewith or, in the event of failure to enter into such Contract and give such bond within the time specified, if the Principal shall pay the City the difference between the amount specified in said bid and the amount for which the City may procure the required work and/or supplies provided the latter amount to be excess of the amount specified in said bid, then the above obligations shall be void: otherwise, to remain in full force and effect.

IN THE WITNESS WHEREOF, the above written parties have executed this instrument under their several seals dated _____, the name and corporate seal of each corporate party being hereto affixed and these presents duly signed by its undersigned representative, pursuant to authority of its governing body.

Witness as to Principal:

(By)

(Principal) (SEAL)

Witness as to Surety:

Printed Name

(Surety's Name) (SEAL)

(By-As Attorney-in-Fact, Surety)

Affix Corporate Seals and attach proper Power of Attorney for Surety.

THIS PAGE MUST BE COMPLETED AND SUBMITTED

ATTACHMENT H

EQUIPMENT

Equipment is located at: _____

Please make sure your list of equipment contains the following: Description of equipment, inclusive of manufacturer, year and condition.

List the condition of equipment/vehicles utilized for this project in accordance with the following scale:

1-Excellent: 2-Good: 3-Fair: 4-Poor. (Attach additional sheets, if required.)

Description	Manufacturer	Year	Condition	Leased/Owned
1. _____				
2. _____				
3. _____				

SOURCE OF SUPPLY AND SUBCONTRACTOR FORM

The following sources of supply and subcontractors shall be used for the **RFB NO. 2023-23 HURRICANE IAN PERMANENT REPAIRS FOR FIXED WEIR (FW) NO. 123 EROSION REPAIRS**. If Bidder does not have a source of supply or subcontractor, insert "to be determined". When a source or subcontractor is determined, selection will be subject to City approval. (If not applicable, state N/A).

SUBCONTRACTOR(S)
(PLEASE INCLUDE ADDRESS/TELEPHONE NUMBER & E-MAIL)

1. _____
2. _____
3. _____

SUPPLIER(S)

1. _____
2. _____
3. _____

Date: _____

Signed (Person authorized to bind the company): _____

Name (printed): _____ Title: _____

THIS PAGE MUST BE COMPLETED AND SUBMITTED

**ATTACHMENT I:
QUALIFICATIONS AND REFERENCES**

Prime bidder must be fully licensed to do business in the State of Florida and be currently licensed as a Certified General Contractor in the State of Florida and provide proof of licensure with the submitted Bid Proposal. Bidders must have successfully completed, as a Prime or Subcontractor, at least two (2) projects, in the past fifteen (15) years of similar type, size and dollar value of the project described herein.

1. Business/Customer Name: _____

Name of Contact Person/Title: _____

Telephone# _____ Fax _____ E-mail _____

Address _____

Phone Number _____

Duration of Contract or business relationship _____

Type of Services Provided _____

Contract Period: FROM _____ TO _____

Contract Price \$ _____ Contract Price at Completion of the Project \$ _____

2. Business/Customer Name: _____

Name of Contact Person/Title: _____

Telephone# _____ Fax _____ E-mail _____

Address _____

Phone Number _____

Duration of Contract or business relationship _____

Type of Services Provided _____

Contract Period: FROM _____ TO _____

Contract Price \$ _____ Contract Price at Completion of the Project \$ _____

Date: _____

Signed (Person authorized to bind the company): _____

Name (printed): _____ Title: _____

THIS PAGE MUST BE COMPLETED AND SUBMITTED

3. Business/Customer Name: _____

Name of Contact Person/Title: _____

Telephone# _____ Fax _____ E-mail _____

Address _____

Contract Period: FROM _____ TO _____

Contract Price \$ _____ Contract Price at Completion of the Project \$ _____

Phone Number _____

Duration of Contract or business relationship _____

Type of Services Provided _____

Contract Period: FROM _____ TO _____

Contract Price \$ _____ Contract Price at Completion of the Project \$ _____

4. Business/Customer Name: _____

Name of Contact Person/Title: _____

Telephone# _____ Fax _____ E-mail _____

Address _____

Phone Number _____

Duration of Contract or business relationship _____

Type of Services Provided _____

Contract Period: FROM _____ TO _____

Contract Price \$ _____ Contract Price at Completion of the Project \$ _____

Date: _____

Signed (*Person authorized to bind the company*): _____

Name (printed): _____ Title: _____

THIS PAGE MUST BE COMPLETED AND SUBMITTED

Attachment 1.1**GENERAL INSURANCE****A. Insurance.**

- (1) Before performing any work pursuant to this Contract, the Contractor must procure and maintain, during the life of this Contract, the insurance listed below against all claims of injury to persons or damage to property which may arise from or in connection with its performance of the Contract work, unless otherwise specified. The policies of insurance must be primary and written on forms acceptable to the City and placed with insurance carriers approved and licensed by the State of Florida Department of Financial Services, and meet a minimum financial A.M. Best and Company, Inc. rating of no less than "A - Excellent: FSC VII." No changes can be made to these specifications without prior written approval by the City Manager or designee. The City Manager or designee may alter the amounts or types of insurance policies required by this Contract upon agreement with the Contractor. The insurance policies must remain in place until all of the Contractor's and subcontractor(s)' obligations and warranty periods in place pursuant to this Contract have been discharged or satisfied.
- (2) The below insurance requirements are minimum requirements for this Contract and in no way limit the indemnity covenants contained in this Contract. The City in no way warrants that the minimum limits are sufficient to protect the Contractor from liabilities that might arise out of the performance of the work done pursuant to this Contract by the Contractor, its agents, representatives, employees, or subcontractors. Contractor is free to purchase additional insurance as it may determine necessary. The extent of Contractor's liability for indemnity of the City must not be limited by insurance coverage or lack thereof, or unreasonably delayed for any reason, including but not limited to, insurance coverage disputes between the Contractor and its carrier.

B. Workers' Compensation and Employers' Liability Insurance. Coverage pursuant to Florida Statutes, Chapter 440 must apply to all employees at the statutory limits provided by state and federal laws. The policy must include Employers' Liability with a limit of \$1,000,000 for each accident; \$1,000,000 each employee; and \$1,000,000 policy limit for bodily injury or disease. Proof of insurance must be filed by the Contractor with the City within **ten (10) calendar days** after the Effective Date of this Contract.

C. Comprehensive Commercial General Liability Insurance. The Contractor must procure and maintain, and require all subcontractors to procure and maintain, during the life of this Contract, a comprehensive commercial general liability policy, including but not limited to bodily injury, property damage, broad form contractual liability and Explosion, Collapse and Underground (XCU) coverage. The general aggregate limit must apply separately to this Contract, or the general aggregate limit must be twice the required occurrence limit.

The policy must include General Liability with a limit of \$1,000,000 for General Aggregate; \$1,000,000 for each occurrence; \$1,000,000 for Products and Completed Operations; \$100,000 for damage to rented premises; and \$100,000 for Fire Damage. Proof of insurance must be filed by the Contractor with the City within **ten (10) calendar days** after the Effective Date of this Contract.

D. Automobile Liability Insurance. The Contractor must procure and maintain, and require all subcontractors to procure and maintain, during the life of this Contract, automobile liability insurance to include all owned, leased, hired, and non-owned vehicles. Automobile liability insurance must be written on a

Attachment 1.1

standard ISO form (CA 00 01) covering any auto (Code 1), or if Contractor has no owned autos, hired (Code 8) and non-owned (Code 9) autos.

The policy must include liability insurance with a limit of \$1,000,000 for Combined Single Limit (CSL) for each accident; \$1,000,000 per person for Bodily Injury; \$1,000,000 per accident for Bodily Injury; and \$1,000,000 per accident for Property Damage. Proof of such insurance must be filed by the Contractor with the City within **ten (10) calendar days** after the Effective Date of this Contract.

E. Waiver of Subrogation. All required insurance policies, except for Workers' Compensation, are to be endorsed with a Waiver of Subrogation. The insurance companies, by proper endorsement or through other means, must agree to waive all rights of subrogation against the City, its Commissioners, officers, officials, employees, volunteers, and the City's insurance carriers, for losses paid under the terms of these policies that arise from the contractual relationship or work performed by the Contractor for the City. It is the Contractor's responsibility to notify its insurance company of the Waiver of Subrogation and request written authorization or the proper endorsement. **ADDITIONALLY, THE CONTRACTOR, ITS OFFICERS, OFFICIALS, AGENTS, EMPLOYEES, VOLUNTEERS, AND ANY SUBCONTRACTORS, AGREE TO WAIVE ALL RIGHTS OF SUBROGATION AGAINST THE CITY AND ITS INSURANCE CARRIERS FOR ANY LOSSES PAID, SUSTAINED, OR INCURRED, BUT NOT COVERED BY INSURANCE, THAT ARISE FROM THE CONTRACTUAL RELATIONSHIP OR WORK PERFORMED. THIS WAIVER APPLIES TO ANY DEDUCTIBLES OR SELF-INSURED RETENTIONS FOR WHICH THE CONTRACTOR OR ITS AGENTS MAY BE RESPONSIBLE.**

F. Policy Form.

(1) All policies required by this Contract, except for Workers' Compensation, or unless specific approval is given by Risk Management through the City's Purchasing Division, are to be written on an occurrence basis, and must name the City of North Port, Florida, its Commissioners, officers, agents, employees, and volunteers as additional insured as their interest may appear under this Contract. Claims Made Policies may be accepted for professional liability, hazardous materials and such other risks as are authorized by the City's Purchasing Division. All Claims Made Policies contributing to the satisfaction of the insurance requirements must have an extended reporting period option or automatic coverage of not less than two (2) years. If provided as an option, Contractor must purchase the extended reporting period on cancellation or termination unless a new policy is affected with a retroactive date, including at least the last policy year.

(2) Insurance requirements itemized in this Contract, and required of the Contractor, must be provided by or on behalf of all subcontractors to cover their operations performed under this Contract. The Contractor is responsible for any modifications, deviations, or omissions in these insurance requirements as they apply to its subcontractors.

(3) Each insurance policy required by this Contract must:

(a) Apply separately to each insured against whom claim is made and suit is brought, except with respect to limits of the insurer's liability.

(b) Be endorsed to state that coverage must not be suspended, voided, or cancelled by either party except after notice is delivered in accordance with the policy provisions. The Contractor is

Attachment 1.1

to notify the City's Purchasing Division of any occurrence by written notice via certified mail, return receipt requested.

- (4) The City retains the right to review, at any time, coverage, form, and amount of insurance.
- (5) The Contractor is solely responsible for payment of all premiums for insurance required in this Contract and is solely responsible for the payment of all deductibles, SIR (self-insured retentions), any loss or portion of any loss that is not covered by any available insurance policy, and retention as set forth in the policies, whether the City is an insured under the policy. Contractor's insurance is considered primary for any loss, regardless of any insurance maintained by the City.
- (6) All certificates of insurance must be on file with and approved by the City before commencement of any work done pursuant to this Contract. All required certificates of insurance must be accompanied by a copy of the additionally insured documents/endorsements (CG 20101185 or combination of CG 2010370704 and CG 20370704). Certificates of insurance evidencing Claims Made or Occurrences form coverage and conditions to this Contract, as well as the Contract number and description of work, are to be furnished to the City's Purchasing Division at 4970 City Hall Boulevard, Suite 337, North Port, FL 34286 prior to commencement of the work and a minimum of **thirty (30) calendar days** prior to expiration of the insurance Contract when applicable. All insurance certificates must be received by the City's Purchasing Division before the Contractor commences or continues work. The certificate of insurance issued by the underwriting department of the insurance carrier must certify compliance with the insurance requirements of this Contract.
- (7) Notices of Accidents (Occurrences) and Notices of Claims associated with work being performed pursuant to this Contract must be provided to Contractor's insurer(s) and the City's Purchasing Division as soon as practicable after notice to the insured Contractor.

Attachment 2.2

CONSTRUCTION SERVICES INDEMNITY, DEFENSE, AND RELEASE

- A. **TO THE EXTENT PERMITTED BY FLORIDA LAW, THE CONTRACTOR ASSUMES ALL LIABILITY FOR, AND RELEASES AND AGREES TO DEFEND, INDEMNIFY, PROTECT, AND HOLD HARMLESS THE CITY, ITS COMMISSIONERS, OFFICERS, AGENTS AND EMPLOYEES, FROM ALL LIABILITIES, FINES, CLAIMS, ASSESSMENTS, SUITS, JUDGMENTS, DAMAGES, LOSSES AND COSTS, INCLUDING CONSEQUENTIAL, SPECIAL, INDIRECT, AND PUNITIVE DAMAGES, (INCLUDING, BUT NOT LIMITED TO, REASONABLE ATTORNEYS' FEES AND COURT COSTS, WHETHER THE FEES AND COSTS ARE INCURRED IN NEGOTIATIONS, AT THE TRIAL LEVEL OR ON APPEAL, OR IN THE COLLECTION OF ATTORNEYS' FEES), ARISING OUT OF ANY ACTS, ACTIONS, BREACHES, NEGLIGENCE OR OMISSIONS OF THE CONTRACTOR, OR THE CONTRACTOR'S OFFICERS, EMPLOYEES, AGENTS, SUB-CONTRACTORS, SUB-CONSULTANTS, AND OTHER PERSONS EMPLOYED OR UTILIZED BY THE CONTRACTOR IN THE PERFORMANCE OF, OR THE FAILURE TO PERFORM, THIS CONTRACT. THIS CONTRACT DOES NOT CONSTITUTE A WAIVER OF SOVEREIGN IMMUNITY OR CONSENT BY THE CITY OR ITS SUBDIVISIONS TO SUIT BY THIRD PARTIES.**
- B. **FURTHER, THE CONTRACTOR SHALL FULLY INDEMNIFY, DEFEND, AND HOLD HARMLESS THE CITY FROM ALL SUITS, ACTIONS, DAMAGES, AND COSTS OF EVERY NAME AND DESCRIPTION, INCLUDING ATTORNEYS' FEES, ARISING FROM OR RELATING TO VIOLATION OR INFRINGEMENT OF A TRADEMARK, COPYRIGHT, PATENT, TRADE SECRET OR INTELLECTUAL PROPERTY RIGHT.**
- C. The City must provide all available information and assistance that the **contractor** may reasonably require regarding any claim. In the event of a claim, the city must promptly notify the **contractor** in writing by prepaid certified mail (return receipt requested) or by delivery through any nationally recognized courier service (such as federal express or ups) which provides evidence of delivery, at the address provided for receipt of notices in this Contract.
- D. The insurance coverage and limits required in this Contract may or may not be adequate to protect the city and such insurance coverage will not be deemed a limitation on the **contractor's** liability under the indemnity provided in this section. In any proceedings between the parties arising out of or related to this indemnity provision, the prevailing party shall be reimbursed all costs, expenses, and reasonable attorney fees through all proceedings (at both trial and appellate levels).
- E. Nothing in this Contract shall be deemed to affect the rights, privileges and immunities of the city as set forth in Florida Statutes Section 768.28.
- F. The terms of this section survive the termination or completion of this Contract work.

Attachment 3**FEMA PROVISIONS****Section 1: Prohibition on Contracting for Covered Telecommunications Equipment or Services**

(a) *Definitions.* As used in this clause, the terms backhaul; covered foreign country; covered telecommunications equipment or services; interconnection arrangements; roaming; substantial or essential component; and telecommunications equipment or services have the meaning as defined in FEMA Policy 405-143-1, Prohibitions on Expending FEMA Award Funds for Covered Telecommunications Equipment or Services (Interim).

(b) *Prohibitions.*

(1) Section 889(b) of the John S. McCain National Defense Authorization Act for Fiscal Year 2019, Pub. L. No. 115-232, and 2 C.F.R. § 200.216 prohibit the head of an executive agency on or after Aug.13, 2020, from obligating or expending grant, cooperative agreement, loan, or loan guarantee funds on certain telecommunications products or from certain entities for national security reasons.

(2) Unless an exception in paragraph (c) of this clause applies, the Contractor and its subcontractors may not use grant, cooperative agreement, loan, or loan guarantee funds from the Federal Emergency Management Agency to:

(i) Procure or obtain any equipment, system, or service that uses covered telecommunications equipment or services as a substantial or essential component of any system, or as critical technology of any system;

(ii) Enter into, extend, or renew a contract to procure or obtain any equipment, system, or service that uses covered telecommunications equipment or services as a substantial or essential component of any system, or as critical technology of any system;

(iii) Enter into, extend, or renew contracts with entities that use covered telecommunications equipment or services as a substantial or essential component of any system, or as critical technology as part of any system; or

(iv) Provide, as part of its performance of this contract, subcontract, or other contractual instrument, any equipment, system, or service that uses covered telecommunications equipment or services as a substantial or essential component of any system, or as critical technology as part of any system.

(c) *Exceptions.*

(1) This clause does not prohibit Contractors from providing—

(i) A service that connects to the facilities of a third-party, such as backhaul, roaming, or interconnection arrangements; or

(ii) Telecommunications equipment that cannot route or redirect user data traffic or permit visibility into any user data or packets that such equipment transmits or otherwise handles.

(2) By necessary implication and regulation, the prohibitions also do not apply to:

(i) Covered telecommunications equipment or services that:

Attachment 3

i. Are *not used* as a substantial or essential component of any system; and

ii. Are *not used* as critical technology of any system.

(ii) Other telecommunications equipment or services that are not considered covered telecommunications equipment or services.

(d) Reporting requirement.

(1) In the event the Contractor identifies covered telecommunications equipment or services used as a substantial or essential component of any system, or as critical technology as part of any system, during contract performance, or the Contractor is notified of such by a subcontractor at any tier or by any other source, the Contractor shall report the information in paragraph (d)(2) of this clause to the recipient or subrecipient, unless elsewhere in this contract are established procedures for reporting the information.

(2) The Contractor shall report the following information pursuant to paragraph (d)(1) of this clause:

(i) Within one business day from the date of such identification or notification: The contract number; the order number(s), if applicable; supplier name; supplier unique entity identifier (if known); supplier Commercial and Government Entity (CAGE) code (if known); brand; model number (original equipment manufacturer number, manufacturer part number, or wholesaler number); item description; and any readily available information about mitigation actions undertaken or recommended.

(ii) Within 10 business days of submitting the information in paragraph (d)(2)(i) of this clause: Any further available information about mitigation actions undertaken or recommended. In addition, the Contractor shall describe the efforts it undertook to prevent use or submission of covered telecommunications equipment or services, and any additional efforts that will be incorporated to prevent future use or submission of covered telecommunications equipment or services.

(e) *Subcontracts*. The Contractor shall insert the substance of this clause, including this paragraph (e), in all subcontracts and other contractual instruments.

Section 2: Domestic Preference for Procurements

As appropriate, and to the extent consistent with law, the Contractor should, to the greatest extent practicable, provide a preference for the purchase, acquisition, or use of goods, products, or materials produced in the United States. This includes, but is not limited to iron, aluminum, steel, cement, and other manufactured products.

For purposes of this clause:

Produced in the United States means, for iron and steel products, that all manufacturing processes, from the initial melting stage through the application of coatings, occurred in the United States.

Manufactured products mean items and construction materials composed in whole or in part of non-ferrous metals such as aluminum; plastics and polymer-based products such as polyvinyl chloride pipe; aggregates such as concrete; glass, including optical fiber; and lumber.

Section 3: Equal Employment Opportunity

Attachment 3

(a) This section applies if the contract is for a federally assisted construction contract. As defined in 41 C.F.R. § 60-1.3:

(1) A *federally assisted construction contract* means "any agreement or modification thereof between any applicant and a person for construction work which is paid for in whole or in part with funds obtained from the Government or borrowed on the credit of the Government pursuant to any federal program involving a grant, contract, loan, insurance or guarantee, or undertaken pursuant to any federal program involving such grant, contract, loan, insurance, or guarantee, or any application or modification thereof approved by the Government for a grant, contract, loan, insurance, or guarantee under which the applicant itself participates in the construction work."

(2) *Construction work* means as "the construction, rehabilitation, alteration, conversion, extension, demolition or repair of buildings, highways, or other changes or improvements to real property, including facilities providing utility services. The term also includes the supervision, inspection, and other onsite functions incidental to the actual construction."

(3) *Contract* means "any Government contract or subcontract or any federally assisted construction contract or subcontract."

(4) Additional definitions pertaining to this section can be found at 41 C.F.R. § 60-1.3.

(b) Unless exempted in 41 C.F.R. Part 60, the following terms apply, and during the performance of this contract, the Contractor agrees as follows:

(1) The Contractor will not discriminate against any employee or applicant for employment because of race, color, religion, sex, sexual orientation, gender identity, or national origin. The Contractor will take affirmative action to ensure that applicants are employed, and that employees are treated during employment without regard to their race, color, religion, sex, sexual orientation, gender identity, or national origin. Such action shall include, but not be limited to the following: employment, upgrading, demotion, or transfer; recruitment or recruitment advertising; layoff or termination; rates of pay or other forms of compensation; and selection for training, including apprenticeship. The Contractor agrees to post in conspicuous places, available to employees and applicants for employment, notices to be provided setting forth the provisions of this nondiscrimination clause.

(2) The Contractor will, in all solicitations or advertisements for employees placed by or on behalf of the Contractor, state that all qualified applicants will receive consideration for employment without regard to race, color, religion, sex, sexual orientation, gender identity, or national origin.

(3) The Contractor will not discharge or in any other manner discriminate against any employee or applicant for employment because such employee or applicant has inquired about, discussed, or disclosed the compensation of the employee or applicant or another employee or applicant. This provision shall not apply to instances in which an employee who has access to the compensation information of other employees or applicants as a part of such employee's essential job functions discloses the compensation of such other employees or applicants to individuals who do not otherwise have access to such information, unless such disclosure is in response to a formal complaint or charge, in furtherance of an investigation, proceeding, hearing, or action, including an investigation conducted by the employer, or is consistent with the Contractor's legal duty to furnish information.

(4) The Contractor will send to each labor union or representative of workers with which he has a collective bargaining agreement or other contract or understanding, a notice to be provided advising the said labor union or workers' representatives of the Contractor's commitments under this section, and shall post copies of the notice in conspicuous places available to employees and applicants for employment.

Attachment 3

(5) The Contractor will comply with all provisions of Executive Order 11246 of September 24, 1965, and of the rules, regulations, and relevant orders of the Secretary of Labor.

(6) The Contractor will furnish all information and reports required by Executive Order 11246 of September 24, 1965, and by rules, regulations, and orders of the Secretary of Labor, or pursuant thereto, and will permit access to his books, records, and accounts by the administering agency and the Secretary of Labor for purposes of investigation to ascertain compliance with such rules, regulations, and orders.

(7) In the event of the Contractor's noncompliance with the nondiscrimination clauses of this contract or with any of the said rules, regulations, or orders, this contract may be canceled, terminated, or suspended in whole or in part and the Contractor may be declared ineligible for further Government contracts or federally assisted construction contracts in accordance with procedures authorized in Executive Order 11246 of September 24, 1965, and such other sanctions may be imposed and remedies invoked as provided in Executive Order 11246 of September 24, 1965, or by rule, regulation, or order of the Secretary of Labor, or as otherwise provided by law.

(8) The Contractor will include the portion of the sentence immediately preceding paragraph (1) and the provisions of paragraphs (1) through (8) in every subcontract or contract unless exempted by rules, regulations, or orders of the Secretary of Labor issued pursuant to section 204 of Executive Order 11246 of September 24, 1965, so that such provisions will be binding upon each subcontractor or vendor. The Contractor will take such action with respect to any subcontract or contract as the administering agency may direct as a means of enforcing such provisions, including sanctions for noncompliance: *Provided*, however, that in the event a Contractor becomes involved in, or is threatened with, litigation with a subcontractor or vendor as a result of such direction by the administering agency, the Contractor may request the United States to enter into such litigation to protect the interests of the United States.

Section 4: Davis-Bacon Act

(a) This section applies when required by federal program legislation for prime construction contracts over \$2,000. The Davis-Bacon Act only applies to the Emergency Management Performance Grant Program, Homeland Security Grant Program, Nonprofit Security Grant Program, Tribal Homeland Security Grant Program, Port Security Grant Program, Transit Security Grant Program, Intercity Passenger Rail Program, and Rehabilitation of High Hazard Potential Dams Program. Unless otherwise stated in a program's authorizing statute, it *does not* apply to other FEMA grant and cooperative agreement programs, including the Public Assistance program. Where this section applies:

(1) Minimum wages.

(i) All laborers and mechanics employed or working upon the site of the work (or under the United States Housing Act of 1937 or under the Housing Act of 1949 in the construction or development of the project), will be paid unconditionally and not less often than once a week, and without subsequent deduction or rebate on any account (except such payroll deductions as are permitted by regulations issued by the Secretary of Labor under the Copeland Act (29 CFR part 3)), the full amount of wages and bona fide fringe benefits (or cash equivalents thereof) due at time of payment computed at rates not less than those contained in the wage determination of the Secretary of Labor which is attached hereto and made a part hereof, regardless of any contractual relationship which may be alleged to exist between the Contractor and such laborers and mechanics. Contributions made or costs reasonably anticipated for bona fide fringe benefits under section 1(b)(2) of the Davis-Bacon Act on behalf of laborers

Attachment 3

or mechanics are considered wages paid to such laborers or mechanics, subject to the provisions of paragraph (a)(1)(iv) of this section; also, regular contributions made or costs incurred for more than a weekly period (but not less often than quarterly) under plans, funds, or programs which cover the particular weekly period, are deemed to be constructively made or incurred during such weekly period. Such laborers and mechanics shall be paid the appropriate wage rate and fringe benefits on the wage determination for the classification of work actually performed, without regard to skill, except as provided in § 5.5(a)(4). Laborers or mechanics performing work in more than one classification may be compensated at the rate specified for each classification for the time actually worked therein: Provided, That the employer's payroll records accurately set forth the time spent in each classification in which work is performed. The wage determination (including any additional classification and wage rates conformed under paragraph (a)(1)(ii) of this section) and the Davis-Bacon poster (WH-1321) shall be posted at all times by the Contractor and its subcontractors at the site of the work in a prominent and accessible place where it can be easily seen by the workers.

(ii)

(A) The contracting officer shall require that any class of laborers or mechanics, including helpers, which is not listed in the wage determination, and which is to be employed under the contract shall be classified in conformance with the wage determination. The contracting officer shall approve an additional classification and wage rate and fringe benefits therefore only when the following criteria have been met:

(1) The work to be performed by the classification requested is not performed by a classification in the wage determination; and

(2) The classification is utilized in the area by the construction industry;
and

(3) The proposed wage rate, including any bona fide fringe benefits, bears a reasonable relationship to the wage rates contained in the wage determination.

(B) If the Contractor and the laborers and mechanics to be employed in the classification (if known), or their representatives, and the contracting officer agree on the classification and wage rate (including the amount designated for fringe benefits where appropriate), a report of the action taken shall be sent by the contracting officer to the Administrator of the Wage and Hour Division, U.S. Department of Labor, Washington, DC 20210. The Administrator, or an authorized representative, will approve, modify, or disapprove every additional classification action within 30 days of receipt and so advise the contracting officer or will notify the contracting officer within the 30-day period that additional time is necessary.

(C) In the event the Contractor, the laborers, or mechanics to be employed in the classification or their representatives, and the contracting officer do not agree on the proposed classification and wage rate (including the amount designated for fringe benefits, where appropriate), the contracting officer shall refer the questions, including the views of all interested parties and the recommendation of the contracting officer, to the Administrator for determination. The Administrator, or an authorized representative, will issue a determination within 30 days of receipt and so advise the contracting officer or will notify the contracting officer within the 30-day period that additional time is necessary.

(D) The wage rate (including fringe benefits where appropriate) determined pursuant to paragraphs (a)(1)(ii) (B) or (C) of this section, shall be paid to all workers performing work in the classification under this contract from the first day on which work is performed in the classification.

Attachment 3

(iii) Whenever the minimum wage rate prescribed in the contract for a class of laborers or mechanics includes a fringe benefit which is not expressed as an hourly rate, the Contractor shall either pay the benefit as stated in the wage determination or shall pay another bona fide fringe benefit or an hourly cash equivalent thereof.

(iv) If the Contractor does not make payments to a trustee or other third person, the Contractor may consider as part of the wages of any laborer or mechanic the amount of any costs reasonably anticipated in providing bona fide fringe benefits under a plan or program, Provided, That the Secretary of Labor has found, upon the written request of the Contractor, that the applicable standards of the Davis-Bacon Act have been met. The Secretary of Labor may require the Contractor to set aside in a separate account assets for the meeting of obligations under the plan or program.

(2) Withholding. The City shall upon its own action or upon written request of an authorized representative of the Department of Labor withhold or cause to be withheld from the Contractor under this contract or any other Federal contract with the same prime Contractor, or any other federally-assisted contract subject to Davis-Bacon prevailing wage requirements, which is held by the same prime Contractor, so much of the accrued payments or advances as may be considered necessary to pay laborers and mechanics, including apprentices, trainees, and helpers, employed by the Contractor or any subcontractor the full amount of wages required by the contract. In the event of failure to pay any laborer or mechanic, including any apprentice, trainee, or helper, employed or working on the site of the work (or under the United States Housing Act of 1937 or under the Housing Act of 1949 in the construction or development of the project), all or part of the wages required by the contract, the (Agency) may, after written notice to the Contractor, sponsor, applicant, or owner, take such action as may be necessary to cause the suspension of any further payment, advance, or guarantee of funds until such violations have ceased.

(3) Payrolls and basic records.

(i) Payrolls and basic records relating thereto shall be maintained by the Contractor during the course of the work and preserved for a period of three years thereafter for all laborers and mechanics working at the site of the work (or under the United States Housing Act of 1937, or under the Housing Act of 1949, in the construction or development of the project). Such records shall contain the name, address, and social security number of each such worker, his or her correct classification, hourly rates of wages paid (including rates of contributions or costs anticipated for bona fide fringe benefits or cash equivalents thereof of the types described in section 1(b)(2)(B) of the Davis-Bacon Act), daily and weekly number of hours worked, deductions made, and actual wages paid. Whenever the Secretary of Labor has found under 29 CFR 5.5(a)(1)(iv) that the wages of any laborer or mechanic include the amount of any costs reasonably anticipated in providing benefits under a plan or program described in section 1(b)(2)(B) of the Davis-Bacon Act, the Contractor shall maintain records which show that the commitment to provide such benefits is enforceable, that the plan or program is financially responsible, and that the plan or program has been communicated in writing to the laborers or mechanics affected, and records which show the costs anticipated or the actual cost incurred in providing such benefits. Contractors employing apprentices or trainees under approved programs shall maintain written evidence of the registration of apprenticeship programs and certification of trainee programs, the registration of the apprentices and trainees, and the ratios and wage rates prescribed in the applicable programs.

(ii)

(A) The Contractor shall submit weekly for each week in which any contract work is performed a copy of all payrolls to the (write in name of appropriate federal agency) if the agency is a party to the contract, but if the agency is not such a party, the Contractor will submit the payrolls to the

Attachment 3

applicant, sponsor, or owner, as the case may be, for transmission to the (write in name of agency). The payrolls submitted shall set out accurately and completely all of the information required to be maintained under 29 CFR 5.5(a)(3)(i), except that full social security numbers and home addresses shall not be included on weekly transmittals. Instead the payrolls shall only need to include an individually identifying number for each employee (e.g., the last four digits of the employee's social security number). The required weekly payroll information may be submitted in any form desired. Optional Form WH-347 is available for this purpose from the Wage and Hour Division Web site at <http://www.dol.gov/esa/whd/forms/wh347instr.htm> or its successor site. The prime Contractor is responsible for the submission of copies of payrolls by all subcontractors. Contractors and subcontractors shall maintain the full social security number and current address of each covered worker, and shall provide them upon request to the (write in name of appropriate federal agency) if the agency is a party to the contract, but if the agency is not such a party, the Contractor will submit them to the applicant, sponsor, or owner, as the case may be, for transmission to the (write in name of agency), the Contractor, or the Wage and Hour Division of the Department of Labor for purposes of an investigation or audit of compliance with prevailing wage requirements. It is not a violation of this section for a prime Contractor to require a subcontractor to provide addresses and social security numbers to the prime Contractor for its own records, without weekly submission to the sponsoring government agency (or the applicant, sponsor, or owner).

(B) Each payroll submitted shall be accompanied by a "Statement of Compliance," signed by the Contractor or subcontractor or his or her agent who pays or supervises the payment of the persons employed under the contract and shall certify the following:

(1) That the payroll for the payroll period contains the information required to be provided under § 5.5 (a)(3)(ii) of Regulations, 29 CFR part 5, the appropriate information is being maintained under § 5.5 (a)(3)(i) of Regulations, 29 CFR part 5, and that such information is correct and complete;

(2) That each laborer or mechanic (including each helper, apprentice, and trainee) employed on the contract during the payroll period has been paid the full weekly wages earned, without rebate, either directly or indirectly, and that no deductions have been made either directly or indirectly from the full wages earned, other than permissible deductions as set forth in Regulations, 29 CFR part 3;

(3) That each laborer or mechanic has been paid not less than the applicable wage rates and fringe benefits or cash equivalents for the classification of work performed, as specified in the applicable wage determination incorporated into the contract.

(C) The weekly submission of a properly executed certification set forth on the reverse side of Optional Form WH-347 shall satisfy the requirement for submission of the "Statement of Compliance" required by paragraph (a)(3)(ii)(B) of this section.

(D) The falsification of any of the above certifications may subject the Contractor or subcontractor to civil or criminal prosecution under section 1001 of title 18 and section 231 of title 31 of the United States Code.

(iii) The Contractor or subcontractor shall make the records required under paragraph (a)(3)(i) of this section available for inspection, copying, or transcription by authorized representatives of the (write the name of the agency) or the Department of Labor, and shall permit such representatives to interview employees during working hours on the job. If the Contractor or subcontractor fails to submit

Attachment 3

the required records or to make them available, the Federal agency may, after written notice to the Contractor, sponsor, applicant, or owner, take such action as may be necessary to cause the suspension of any further payment, advance, or guarantee of funds. Furthermore, failure to submit the required records upon request or to make such records available may be grounds for debarment action pursuant to 29 CFR 5.12.

(4) Apprentices and trainees -

(i) Apprentices. Apprentices will be permitted to work at less than the predetermined rate for the work they performed when they are employed pursuant to and individually registered in a bona fide apprenticeship program registered with the U.S. Department of Labor, Employment and Training Administration, Office of Apprenticeship Training, Employer and Labor Services, or with a State Apprenticeship Agency recognized by the Office, or if a person is employed in his or her first 90 days of probationary employment as an apprentice in such an apprenticeship program, who is not individually registered in the program, but who has been certified by the Office of Apprenticeship Training, Employer and Labor Services or a State Apprenticeship Agency (where appropriate) to be eligible for probationary employment as an apprentice. The allowable ratio of apprentices to journeymen on the job site in any craft classification shall not be greater than the ratio permitted to the Contractor as to the entire work force under the registered program. Any worker listed on a payroll at an apprentice wage rate, who is not registered or otherwise employed as stated above, shall be paid not less than the applicable wage rate on the wage determination for the classification of work actually performed. In addition, any apprentice performing work on the job site in excess of the ratio permitted under the registered program shall be paid not less than the applicable wage rate on the wage determination for the work actually performed. Where a Contractor is performing construction on a project in a locality other than that in which its program is registered, the ratios and wage rates (expressed in percentages of the journeyman's hourly rate) specified in the Contractor's or subcontractor's registered program shall be observed. Every apprentice must be paid at not less than the rate specified in the registered program for the apprentice's level of progress, expressed as a percentage of the journeymen hourly rate specified in the applicable wage determination. Apprentices shall be paid fringe benefits in accordance with the provisions of the apprenticeship program. If the apprenticeship program does not specify fringe benefits, apprentices must be paid the full amount of fringe benefits listed on the wage determination for the applicable classification. If the Administrator determines that a different practice prevails for the applicable apprentice classification, fringes shall be paid in accordance with that determination. In the event the Office of Apprenticeship Training, Employer and Labor Services, or a State Apprenticeship Agency recognized by the Office, withdraws approval of an apprenticeship program, the Contractor will no longer be permitted to utilize apprentices at less than the applicable predetermined rate for the work performed until an acceptable program is approved.

(ii) Trainees. Except as provided in 29 CFR 5.16, trainees will not be permitted to work at less than the predetermined rate for the work performed unless they are employed pursuant to and individually registered in a program which has received prior approval, evidenced by formal certification by the U.S. Department of Labor, Employment and Training Administration. The ratio of trainees to journeymen on the job site shall not be greater than permitted under the plan approved by the Employment and Training Administration. Every trainee must be paid at not less than the rate specified in the approved program for the trainee's level of progress, expressed as a percentage of the journeyman hourly rate specified in the applicable wage determination. Trainees shall be paid fringe benefits in accordance with the provisions of the trainee program. If the trainee program does not mention fringe benefits, trainees shall be paid the full amount of fringe benefits listed on the wage determination unless the Administrator of the Wage and Hour Division determines that there is an apprenticeship program

Attachment 3

associated with the corresponding journeyman wage rate on the wage determination which provides for less than full fringe benefits for apprentices. Any employee listed on the payroll at a trainee rate who is not registered and participating in a training plan approved by the Employment and Training Administration shall be paid not less than the applicable wage rate on the wage determination for the classification of work actually performed. In addition, any trainee performing work on the job site in excess of the ratio permitted under the registered program shall be paid not less than the applicable wage rate on the wage determination for the work actually performed. In the event the Employment and Training Administration withdraws approval of a training program, the Contractor will no longer be permitted to utilize trainees at less than the applicable predetermined rate for the work performed until an acceptable program is approved.

(iii) Equal employment opportunity. The utilization of apprentices, trainees and journeymen under this part shall be in conformity with the equal employment opportunity requirements of Executive Order 11246, as amended, and 29 CFR part 30.

(5) Compliance with Copeland Act requirements. The Contractor shall comply with the requirements of 29 CFR part 3, which are incorporated by reference in this contract.

(6) Subcontracts. The Contractor or subcontractor shall insert in any subcontracts the clauses contained in 29 CFR 5.5(a)(1) through (10) and such other clauses as the (write in the name of the Federal agency) may by appropriate instructions require, and also a clause requiring the subcontractors to include these clauses in any lower tier subcontracts. The prime Contractor shall be responsible for the compliance by any subcontractor or lower tier subcontractor with all the contract clauses in 29 CFR 5.5.

(7) Contract termination: debarment. A breach of the contract clauses in 29 CFR 5.5 may be grounds for termination of the contract, and for debarment as a Contractor and a subcontractor as provided in 29 CFR 5.12.

(8) Compliance with Davis-Bacon and Related Act requirements. All rulings and interpretations of the Davis-Bacon and Related Acts contained in 29 CFR parts 1, 3, and 5 are herein incorporated by reference in this contract.

(9) Disputes concerning labor standards. Disputes arising out of the labor standards provisions of this contract shall not be subject to the general disputes clause of this contract. Such disputes shall be resolved in accordance with the procedures of the Department of Labor set forth in 29 CFR parts 5, 6, and 7. Disputes within the meaning of this clause include disputes between the Contractor (or any of its subcontractors) and the contracting agency, the U.S. Department of Labor, or the employees or their representatives.

(10) Certification of eligibility.

(i) By entering into this contract, the Contractor certifies that neither it (nor he or she) nor any person or firm who has an interest in the Contractor's firm is a person or firm ineligible to be awarded Government contracts by virtue of section 3(a) of the Davis-Bacon Act or 29 CFR 5.12(a)(1).

(ii) No part of this contract shall be subcontracted to any person or firm ineligible for award of a Government contract by virtue of section 3(a) of the Davis-Bacon Act or 29 CFR 5.12(a)(1).

(iii) The penalty for making false statements is prescribed in the U.S. Criminal Code, 18 U.S.C. 1001.

Section 5: Copeland Anti-Kickback Act

Attachment 3

(a) This section applies only if the Davis-Bacon Act applies (see Section 4).

(b) The Contractor shall comply with 18 U.S.C. § 874, 40 U.S.C. § 3145, and the requirements of 29 C.F.R. Part 3 as may be applicable, which are incorporated by reference into this contract.

(c) The Contractor or subcontractor shall insert in any subcontracts the clause above and such other clauses as FEMA may by appropriate instructions require, and also a clause requiring the subcontractors to include these clauses in any lower tier subcontracts. The prime Contractor shall be responsible for the compliance by any subcontractor or lower tier subcontractor with all of these contract clauses.

(d) A breach of the contract clauses above may be grounds for termination of the contract, and for debarment as a contractor and subcontractor as provided in 29 C.F.R. § 5.12.

Section 6: Contract Work Hours and Safety Standards Act

(a) This section applies to all procurements over \$100,000 that involve the employment of mechanics, laborers, and construction work. These requirements do not apply to the purchase of supplies or materials or articles ordinarily available on the open market, or contracts for transportation or transmission of intelligence.

(b) Where this section applies:

(1) Overtime requirements. No contractor or subcontractor contracting for any part of the contract work which may require or involve the employment of laborers or mechanics shall require or permit any such laborer or mechanic in any workweek in which he or she is employed on such work to work in excess of forty hours in such workweek unless such laborer or mechanic receives compensation at a rate not less than one and one-half times the basic rate of pay for all hours worked in excess of forty hours in such workweek.

(2) Violation; liability for unpaid wages; liquidated damages. In the event of any violation of the clause set forth in paragraph (b)(1) of this section the contractor and any subcontractor responsible therefor shall be liable for the unpaid wages. In addition, such contractor and subcontractor shall be liable to the United States (in the case of work done under contract for the District of Columbia or a territory, to such District or to such territory), for liquidated damages. Such liquidated damages shall be computed with respect to each individual laborer or mechanic, including watchmen and guards, employed in violation of the clause set forth in paragraph (b)(1) of this section, in the sum of \$27 for each calendar day on which such individual was required or permitted to work in excess of the standard workweek of forty hours without payment of the overtime wages required by the clause set forth in paragraph (b)(1) of this section.

(3) Withholding for unpaid wages and liquidated damages. The City shall upon its own action or upon written request of an authorized representative of the Department of Labor withhold or cause to be withheld, from any moneys payable on account of work performed by the contractor or subcontractor under any such contract or any other federal contract with the same prime Contractor, or any other federally-assisted contract subject to the Contract Work Hours and Safety Standards Act, which is held by the same prime Contractor, such sums as may be determined to be necessary to satisfy any liabilities of such contractor or subcontractor for unpaid wages and liquidated damages as provided in the clause set forth in paragraph (b)(2) of this section.

(4) Subcontracts. The Contractor or subcontractor shall insert in any subcontracts the clauses set forth in paragraph (b)(1) through (4) of this section and also a clause requiring the

Attachment 3

subcontractors to include these clauses in any lower tier subcontracts. The prime Contractor shall be responsible for compliance by any subcontractor or lower tier subcontractor with the clauses set forth in paragraphs (b)(1) through (4) of this section.

(c) If this contract is only subject to Contract Work Hours and Safety Standards Act and not subject to the other statutes in 29 C.F.R. § 5.1, the following terms apply:

(1) The Contractor or subcontractor shall maintain payrolls and basic payroll records during the course of the work and shall preserve them for a period of three years from the completion of the contract for all laborers and mechanics, including guards and watchmen, working on the contract. Such records shall contain the name and address of each such employee, social security number, correct classifications, hourly rates of wages paid, daily and weekly number of hours worked, deductions made, and actual wages paid.

(2) Records to be maintained under this provision shall be made available by the Contractor or subcontractor for inspection, copying, or transcription by authorized representatives of the Department of Homeland Security, the Federal Emergency Management Agency, and the Department of Labor, and the Contractor or subcontractor will permit such representatives to interview employees during working hours on the job.

Section 7: Clean Air and Water

(a) This section applies if the contract is over \$150,000.

(b) The Contractor agrees to comply with all applicable standards, orders or regulations issued pursuant to the Clean Air Act, as amended, 42 U.S.C. § 7401 et seq. The Contractor agrees to report each violation to the City and understands and agrees that the City will, in turn, report each violation as required to assure notification to the State of Florida, FEMA, and the appropriate Environmental Protection Agency Regional Office. The Contractor agrees to include these requirements in each subcontract exceeding \$150,000 financed in whole or in part with federal assistance provided by FEMA.

(c) The Contractor agrees to comply with all applicable standards, orders, or regulations issued pursuant to the federal Water Pollution Control Act, as amended, 33 U.S.C. § 1251 et seq. The Contractor agrees to report each violation to the City and understands and agrees that the City will, in turn, report each violation as required to assure notification to the State of Florida, FEMA, and the appropriate Environmental Protection Agency Regional Office. The Contractor agrees to include these requirements in each subcontract exceeding \$150,000 financed in whole or in part with federal assistance provided by FEMA.

Section 8: Suspension and Debarment

(a) If this contract is for \$25,000 or more, or requires the consent of an official of a federal agency, then this contract is a covered transaction for purposes of 2 C.F.R. Part 180 and 2 C.F.R. Part 3000. As such, the Contractor is required to verify that none of the Contractor's principals (defined at 2 C.F.R. § 180.995) or its affiliates (defined at 2 C.F.R. § 180.905) are excluded (defined at 2 C.F.R. § 180.940) or disqualified (defined at 2 C.F.R. § 180.935). The Contractor must comply with 2 C.F.R. Part 180, subpart C and 2 C.F.R. Part 3000, subpart C, and must include a requirement to comply with these regulations in any lower tier covered transaction it enters into. The Contractor agrees to comply with the requirements of 2 C.F.R. Part 180, subpart C and 2 C.F.R. Part 3000, subpart C throughout the period of the contract.

Attachment 3

(b) This certification is a material representation of fact relied upon by the City. If it is later determined that the Contractor did not comply with 2 C.F.R. Part 180, subpart C and 2 C.F.R. Part 3000, subpart C, in addition to remedies available to the City, the federal government may pursue available remedies, including but not limited to suspension and/or debarment.

Section 9: Byrd Anti-Lobbying Amendment

Contractors who apply or bid for an award of more than \$100,000 shall file the FEMA-required certification found at 44 C.F.R. Part 18, Appendix A (attached hereto). Each tier certifies to the tier above that it will not and has not used federally appropriated funds to pay any person or organization for influencing or attempting to influence an officer or employee of any agency, a Member of Congress, officer or employee of Congress, or an employee of a Member of Congress in connection with obtaining any federal contract, grant, or any other award covered by 31 U.S.C. § 1352. Each tier shall also disclose any lobbying with non-federal funds that takes place in connection with obtaining any federal award. Such disclosures are forwarded from tier to tier up to the recipient who in turn will forward the certification(s) to the federal awarding agency.

Section 10: Procurement of Recovered Materials

(a) In the performance of this contract, the Contractor shall make maximum use of products containing recovered materials that are EPA-designated items unless the product cannot be acquired—
 competitively within a timeframe providing for compliance with the contract performance schedule;
 meeting contract performance requirements; or
 at a reasonable price.

Information about this requirement, along with the list of EPA-designated items, is available at EPA's Comprehensive Procurement Guidelines webpage: <https://www.epa.gov/smm/comprehensive-procurement-guideline-cpg-program>.

(b) The Contractor also agrees to comply with all other applicable requirements of Section 6002 of the Solid Waste Disposal Act.

Section 11: Access to Records

(a) The Contractor agrees to provide the City, the State of Florida, the FEMA Administrator, the Comptroller General of the United States, or any of their authorized representatives access to any books, documents, papers, and records of the Contractor which are directly pertinent to this contract for the purposes of making audits, examinations, excerpts, and transcriptions. The Contractor agrees to permit any of the foregoing parties to reproduce by any means whatsoever or to copy excerpts and transcriptions as reasonably needed.

(b) The Contractor agrees to provide the FEMA Administrator or his authorized representatives access to construction or other work sites pertaining to the work being completed under the contract.

(c) In compliance with section 1225 of the Disaster Recovery Reform Act of 2018, the City and the Contractor acknowledge and agree that no language in this contract is intended to prohibit audits or internal reviews by the FEMA Administrator or the Comptroller General of the United States.

Attachment 3**Section 12: DHS Seal, Logo, and Flags**

The Contractor shall not use the Department of Homeland Security (DHS) seal(s), logos, crests, or reproductions of flags or likenesses of DHS agency officials without specific FEMA pre-approval. The Contractor shall include this provision in any subcontracts.

Section 13: Compliance with Federal Law

The Contractor acknowledges that FEMA financial assistance will be used to fund all or a portion of the contract. The Contractor will comply with all applicable federal law, regulations, executive orders, FEMA policies, procedures, and directives.

Section 14: No Obligation of Federal Government

The federal government is not a party to this contract and is not subject to any obligations or liabilities to the non-federal entity, Contractor, or any other party pertaining to any matter resulting from the contract.

Section 15: False Claims

The Contractor acknowledges that 31 U.S.C. Chap. 38 (Administrative Remedies for False Claims and Statements) applies to the Contractor's actions pertaining to this contract.

Section 16: Affirmative Socioeconomic Steps

If subcontracts are to be let, the prime Contractor is required to take all necessary steps identified in 2 C.F.R. § 200.321(b)(1)-(5) to ensure that small and minority businesses, women's business enterprises, and labor surplus area firms are used when possible.

Section 17: Copyright and Data Rights

If the contract requires the Contractor or subcontractor to produce copyrightable subject matter or data, then the Contractor grants to the City, a paid-up, royalty-free, nonexclusive, irrevocable, worldwide license in data first produced in the performance of this contract to reproduce, publish, or otherwise use, including prepare derivative works, distribute copies to the public, and perform publicly and display publicly such data. For data required by the contract but not first produced in the performance of this contract, the Contractor will identify such data and grant to the City or acquires on its behalf a license of the same scope as for data first produced in the performance of this contract. Data, as used herein, shall include any work subject to copyright under 17 U.S.C. § 102, for example, any written reports or literary works, software and/or source code, music, choreography, pictures or images, graphics, sculptures, videos, motion pictures or other audiovisual works, sound and/or video recordings, and architectural works. Upon or before the completion of this contract, the Contractor will deliver to the City data first produced in the performance of this contract and data required by the contract but not first produced in the performance of this contract in formats acceptable by the City.

Attachment 3

Section 18: Patent Rights

If this contract is a *funding agreement* as defined in 37 C.F.R. § 401.2(a), then the standard patents rights clause at 37 C.F.R. § 401.14 is hereby incorporated by reference as if fully set forth herein.

Attachment 5

CERTIFICATION REGARDING LOBBYING

The undersigned certifies, to the best of his or her knowledge, that:

1. No Federal appropriated funds have been paid or will be paid, by or on behalf of the undersigned, to any person for influencing or attempting to influence an officer or employee of an agency, a Member of Congress, an officer or employee of Congress, or an employee of a Member of Congress in connection with the awarding of any Federal contract, the making of any Federal grant, the making of any Federal loan, the entering into of any cooperative agreement, and the extension, continuation, renewal, amendment, or modification of any Federal contract, grant, loan, or cooperative agreement.
2. If any funds other than Federal appropriated funds have been paid or will be paid to any person for influencing or attempting to influence an officer or employee of any agency, a Member of Congress, an officer or employee of Congress, or an employee of a Member of Congress in connection with this Federal contract, grant, loan, or cooperative agreement, the undersigned shall complete and submit Standard Form-LLL, "Disclosure Form to Report Lobbying," in accordance with its instructions.
3. The undersigned shall require that the language of this certification be included in the award documents for all subawards at all tiers (including subcontracts, subgrants, and contracts under grants, loans, and cooperative agreements) and that all subrecipients shall certify and disclose accordingly.

This certification is a material representation of fact upon which reliance was placed when this transaction was made or entered into. Submission of this certification is a prerequisite for making or entering into this transaction imposed by 31, U.S.C. § 1352 (as amended by the Lobbying Disclosure Act of 1995). Any person who fails to file the required certification shall be subject to a civil penalty of not less than \$10,000 and not more than \$100,000 for each such failure.

The Contractor certifies or affirms the truthfulness and accuracy of each statement of its certification and disclosure, if any. In addition, the Contractor understands and agrees that the provisions of 31 U.S.C. § 3801 et seq., apply to this certification and disclosure, if any.

Signature of Contractor's Authorized Representative

Name

Title

Date

Attachment 6

NON-COLLUSIVE AFFIDAVIT

Before me, the undersigned authority ("Affiant"), personally appeared:

_____ who, being first duly sworn, deposes and says that:

1. Affiant is the _____ **[insert Owner, Partner, Officer, Representative or Agent]** of _____, **[insert name of Contractor]** the Respondent that has submitted the attached reply;
2. Affiant is fully informed respecting the preparation and contents of the attached reply and of all pertinent circumstances respecting such reply;
3. Such reply is genuine and is not a collusive or sham reply;
4. Neither the said Respondent nor any of its officers, partners, owners, agents, representatives, employees or parties in interest, including this affiant, have in any way colluded, conspired, connived or agreed, directly or indirectly, with any other respondent, firm, or person to submit a collusive or sham reply in connection with the work for which the attached reply has been submitted: or have in any manner, directly or indirectly sought by agreement or collusion, or communication or conference with any respondent, firm, or person to fix the price or prices in the attached reply or of any other respondent, or to fix any overhead, profit, or cost elements of the reply price or the reply price of any other respondent, or to secure through any collusion, conspiracy, connivance, or unlawful agreement any advantage against (Recipient), or any person interested in the reply work.

Signed, sealed, and delivered on _____, 20_____.

Signature

Printed Name

Title

SWORN ACKNOWLEDGMENT

STATE OF _____
COUNTY OF _____

Sworn to (or affirmed) and subscribed before me by means of ____ physical presence or ____ online notarization, this ____ day of _____ 2023, by _____.

Notary Public

Personally Known ____ OR Produced Identification ____
Type of Identification Produced _____

Attachment 7
CONFLICT OF INTEREST FORM

Florida Statutes Section 112.313 places limitations on public officers (including advisory board members) and employees' ability to contract with the City of North Port, Florida ("City") either directly or indirectly.

PART I. *[Select and complete all that apply]:*

I am an employee, public officer, or advisory board member of the City.

Identify the position and/or board: _____

I am the spouse or child of an employee, public officer, or advisory board member of the City.

Identify the name of the spouse or child: _____

I am an employee, public officer or advisory board member of the City, or my spouse or child, is an officer, partner, director, or proprietor of Respondent/Contractor or has a material interest in Contractor. "Material interest" means direct or indirect ownership of more than 5 percent of the total assets or capital stock of any business entity. For the purposes of Florida Statutes Section 112.313, indirect ownership does not include ownership by a spouse or minor child.

Identify the name of the person and the entity _____

Bidder/Contractor employs or contracts with an employee, public officer, or advisory board member of the City.

Identify the name of the employee, public officer, or advisory board member _____

None of the Above

PART II: Will you request an advisory board member waiver?

I WILL request an advisory board member waiver under §112.313(12)

I WILL NOT request an advisory board member waiver under §112.313(12)

N/A

The City will review any relationships which may be prohibited under the Florida Ethics Code and will disqualify any Contractor whose conflicts are not waived or exempt.

Signature of Person Authorized to Bind the Contractor

Printed Name

Title

Date

Attachment 8

PUBLIC ENTITY CRIME INFORMATION

As provided by F.S. §287.133, a person or affiliate who has been placed on the convicted vendor list following a conviction for a public entity crime may not submit a bid on a Contract to provide any goods or services to a public entity, may not submit a bid on a Contract with a public entity for the construction or repair of a public building or public work, may not submit bids on leases of real property to a public entity, may not be awarded or perform work as a Contractor, supplier, Subcontractor, or Consultant under a Contract with any public entity, and may not transact business with any public entity in excess of the threshold amount provided in Section 287, for CATEGORY TWO for a period of 36 months from the date of being placed on the convicted vendor list.

I, _____, being an authorized representative of the Contractor, have read and understand the contents above.

I certify that the Contractor is not disqualified from replying to this solicitation/contracting because of Florida Statutes Section 287.133.

Telephone #: _____ Fax #: _____

Federal ID #: _____ Email: _____

Signature of Contractor’s Authorized Representative

Name and Title of Contractor’s Authorized Representative

Date

SWORN ACKNOWLEDGMENT

STATE OF FLORIDA
COUNTY OF _____

Sworn to (or affirmed) and subscribed before me by means of ____ physical presence or ____ online notarization, this ____ day of _____ 2023, by _____.

Notary Public – State of Florida

Personally Known _____ OR Produced Identification _____
Type of Identification Produced _____

Attachment 9

DRUG FREE WORKPLACE FORM

The undersigned, in accordance with Florida Statutes Section 287.087, hereby certifies that the Contractor,
_____ (Company Name):

1. Publishes a statement notifying employees that the unlawful manufacture, distribution, dispensing, possession, or use of a controlled substance is prohibited in the workplace and specifying the actions that will be taken against employees for violations of such prohibition.
2. Informs employees about the dangers of drug abuse in the workplace, the business’s policy of maintaining a drug free workplace, any available drug counseling, rehabilitation, and employee assistance programs, and the penalties that may be imposed upon employees for drug abuse violations.
3. Gives each employee engaged in providing the commodities or Contractual services that are under bid a copy of the statement specified in subsection (1).
4. In the statement specified in subsection (1), notifies employees that, as a condition of working on the commodities or Contractual services that are under bid, the employee will abide by the terms of the statement and will notify the employer of any conviction of, or plea of guilty or nolo contendere to, any violation of Chapter 893 or of any controlled substance law of the United States or any state, for a violation occurring in the workplace no later than five (5) days after such conviction.
5. Imposes a sanction on or require the satisfactory participation in a drug abuse assistance or rehabilitation program if such is available in the employee’s community, by any employee who is so convicted.
6. Makes a good faith effort to continue to maintain a drug free workplace through implementation of this section.

Check one:

_____ As the person authorized to sign this statement, I certify that this firm complies fully with above requirements.

_____ As the person authorized to sign this statement, this firm **does not** comply fully with the above requirements.

Signature

Printed Name

Title

Date

Attachment 10

SWORN STATEMENT: THE FLORIDA TRENCH SAFETY ACT

1. This Sworn Statement is submitted with Contract No. 2023-23 for the construction of Hurricane Ian Permanent Repairs for Fixed Weir (FW) No.123 Erosion Repairs.
2. This Sworn Statement is submitted by _____ ("Contractor") whose business address is _____ and (if applicable) its Federal Employer Identification Number (FEIN) is _____.
3. The Trench Safety Standards that will be in effect during the construction of this Project are Florida Statute Section 553.60-55.64, Trench Safety Act, and OSHA Standard.
4. The undersigned assures that the entity will comply with the applicable Trench Safety Standards and agrees to indemnify and hold harmless the County and ENGINEER, and any of their agents or employees from any claims arising from the failure to comply with said standard.
5. The Contractor has appropriated \$ _____ per linear foot of trench to be excavated over 5' deep for compliance with the applicable standards and intends to comply by instituting the following procedures: _____
6. The Contractor has appropriated \$ _____ per square foot for compliance with shoring safety requirements and intends to comply by instituting the following procedures:
7. The undersigned, in signing this Sworn Statement, represents that he or she has reviewed and considered all available geotechnical information and made such other investigations and tests as he or she may deem necessary to adequately design the trench safety system(s) the Contractor will utilize on this Project.

Signature

Name

Title

SWORN ACKNOWLEDGEMENT

STATE OF _____
COUNTY OF _____

Sworn to (or affirmed) and subscribed before me by means of physical presence or online notarization, this ___ day of _____ 20__, by _____ (name), as _____ (title) for _____ (entity).

Notary Public

___ Personally Known OR ___ Produced Identification
Type of Identification Produced _____

Attachment 11

SCRUTINIZED COMPANY CERTIFICATION FORM

Contractor Name: _____

Authorized Representative Name and Title: _____

Address: _____ City: _____ State: _____ ZIP: _____

Phone Number: _____ Email Address: _____

A company is ineligible to, and may not, bid on, submit a proposal for, or enter into or renew a Contract with the City of North Port for goods or services of any amount if, at the time of bidding on, submitting a proposal for, or entering into or renewing such Contract, the company is on the Scrutinized Companies that Boycott Israel List, created pursuant to Florida Statutes, section 215.4725, or is engaged in a boycott of Israel.

A company is ineligible to, and may not, bid on, submit a proposal for, or enter into or renew a Contract with the City of North Port for goods or services of \$1 million or more if, at the time of bidding on, submitting a proposal for, or entering into or renewing such Contract, the company is on the Scrutinized Companies with Activities in Sudan List, the Scrutinized Companies with Activities in the Iran Petroleum Energy Sector List, created pursuant to Florida Statutes, section 215.473, or with companies engaged in business operations in Cuba or Syria.

CHOOSE ONE OF THE FOLLOWING

____ This Contract or Contract renewal is for goods or services of less than \$1 million. As the person authorized to sign on behalf of the above-named company, and as required by Florida Statutes Section 287.135(5), I hereby certify that the above-named company is not participating in a boycott of Israel.

____ This bid, proposal, Contract or Contract renewal is for goods or services of \$1 million or more. As the person authorized to sign on behalf of the above-named company, and as required by Florida Statutes Section 287.135(5), I hereby certify that the above-named company is not participating in a boycott of Israel, is not on the Scrutinized Companies with Activities in Sudan List or the Scrutinized Companies with Activities in the Iran Petroleum Energy Sector List, and it does not have business operations in Cuba or Syria.

I understand that pursuant to Florida Statutes, section 287.135, the submission of a false certification may result in the termination of the Contract if one is entered into, and may subject the above-named company to civil penalties, attorney's fees and costs.

Certified By:

Signature of Contractor's Authorized Representative

Name

Title

Date

Attachment 12

VENDOR’S CERTIFICATION FOR E-VERIFY SYSTEM

The undersigned Vendor/Consultant/Contractor (Vendor), after being duly sworn, states the following:

- 1. Vendor is a person or entity that has entered into or is attempting to enter into a contract with the City of North Port (City) to provide labor, supplies, or services to the City in exchange for salary, wages or other remuneration.
- 2. Vendor has registered with and will use the E-Verify System of the United States Department of Homeland Security to verify the employment eligibility of:
 - a. All persons newly hired by the Vendor to perform employment duties within Florida during the term of the contract; and
 - b. All persons, including sub-contractors, sub-vendors or sub-consultants, assigned by the Vendor to perform work pursuant to the contract with the City.
- 3. If the Vendor becomes the successful Contractor who enters into a contract with the City, then the Vendor will comply with the requirements of Section 448.095, Fla. Stat. “Employment Eligibility”, as amended from time to time.
- 4. Vendor will obtain an affidavit from all subcontractors attesting that the subcontractor does not employ, contract with, or subcontract with, an unauthorized alien as defined in 8 United States Code, Section 1324A(H)(3).
- 5. Vendor will maintain the original affidavit of all subcontractors for the duration of the contract.
- 6. Vendor affirms that failure to comply with the state law requirements can result in the City’s termination of the contract and other penalties as provided by law.
- 7. Vendor understands that pursuant to Florida Statutes, section 448.095, the submission of a false certification may result in the termination of the contract if one is entered into, and may subject the Vendor named in this certification to civil penalties, attorney's fees and costs.

VENDOR: _____ (Vendor’s Company Name)

Certified By: _____
AUTHORIZED REPRESENTATIVE SIGNATURE

Print Name and Title: _____

Date Certified: _____

Attachment 13**PERFORMANCE AND PAYMENT BOND REQUIREMENTS****A. Security.**

- (1) The Contractor must provide the required performance and payment bond or other acceptable security to the City within **ten (10) business days** of executing this Contract. Failure by the Contractor to provide the bond within **ten (10) business days** constitutes a default. Pursuant to Section 2-404 of the Code of City of North Port, Florida, upon default the City may immediately award the bid to the next lowest responsive and responsible bidder and recover from the original successful bidder the difference in cost between the original winning bid and the next lowest responsive and responsible bidder. The default is only curable at the option of the City.
- (2) In addition, the Contractor is responsible and bears all cost associated with recording the Performance and Payment Bond with the Sarasota County Clerk's Office. The Contractor must furnish the receipt of the recording and certified copy of the recorded bond to the Purchasing Department at the time of the pre-construction meeting. Such default is only curable at the option of the City.

B. Performance and Payment Bond. The Contractor must provide a Performance and Payment Bond, in the form prescribed in Florida Statutes Section 255.05, in the amount of one hundred percent (100%) of the Contract price, the costs of which are to be paid by the Contractor. The bond must be acceptable to the City only if the Surety Company:

- (1) Is licensed to do business in the State of Florida;
- (2) Holds a certificate of authority authorizing it to write surety bonds in the State of Florida;
- (3) Has twice the minimum surplus and capital required by the Florida Insurance Code at the time the invitation to bid is issued;
- (4) Is otherwise in compliance with the provisions of the Florida Insurance Code;
- (5) Holds a currently valid certificate of authority issued by the United States Department of Treasury under 31 U.S.C. §§ 9304-9308;
- (6) Has a current rating of at least Excellent (A or A-) as reported in the most current Best Key Rating Guide, published by A.M. Best Company, Inc., of 75 Fulton Street, New York, New York 10038; and
- (7) Has an underwriting limitation of at least two times the dollar amount of the Contract price.

C. Substitute Bond Required. If the Surety Company for any bond furnished by the Contractor files for bankruptcy, has a receiver appointed, is declared bankrupt, becomes insolvent, has an assignment made for the benefit of creditors, has its right to do business terminated in the State of Florida, or ceases to meet the requirements imposed by this Contract, the Contractor must, within **five (5) calendar days** thereafter, substitute another Bond and Surety Company, both of which are subject to the City's approval.**D. Surety Acceptance of Terms.** By execution of the bond, the Surety Company acknowledges that it has read the surety qualifications and surety obligations imposed by this Contract and satisfies all conditions.

Attachment 14

PERFORMANCE AND PAYMENT BOND

In compliance with F.S. Section 255.05(10) and Code of the City of North Port Sec. 2-414

BOND NO.: _____
BOND AMOUNT: \$ _____

CONTRACTOR NAME: _____
PRINCIPAL ADDRESS: _____
PRINCIPAL PHONE NO.: _____

SURETY COMPANY NAME: _____
SURETY AGENT: _____
PRINCIPAL ADDRESS: _____
PRINCIPAL PHONE NO.: _____

CITY NAME: City of North Port, Florida
PRINCIPAL ADDRESS: 4970 City Hall Boulevard
North Port, Florida 34286
CITY CONTACT PHONE NO.: (941) 240.8063

CONTRACT NO.: (if applicable) 2023-23
PROJECT ADDRESS: _____
(if applicable) North Port, Florida 34286

DESCRIPTION OF PROJECT: _____
(if applicable) _____

DESCRIPTION OF IMPROVEMENT: _____

Attachment 14

By this Bond, we, _____, as Principal (“Contractor”) and _____, a corporation organized and existing under the laws of the State of _____, with its principal office in the City of _____, as Surety (“Surety”) are held firmly bound unto the City of North Port, Florida, as Obligee (“City”), in the amount of _____ Dollars (\$_____), for the payment whereof Contractor and Surety bind themselves, their heirs, executors, administrators, personal representatives, successors, and assigns, jointly and severally, firmly by these presents.

WHEREAS, Contractor has by written agreement dated _____, entered into a Contract with City for _____
_____ in accordance with drawings and specifications prepared by _____
_____, which Contract is by reference made a part hereof, and is hereinafter referred to as the CONTRACT.

NOW, THEREFORE, THE CONDITION OF THIS BOND is such that if Contractor:

- 1. Performs the Contract dated _____, between Contractor and City for construction for the **DESCRIPTION** the Contract being made a part of this bond by reference, at the times and in the manner prescribed in the Contract: and
- 2. Promptly makes payments to all claimants, as defined in Section 255.05(1), Florida Statutes, supplying Contractor with labor, materials, or supplies, used directly or indirectly by Contractor in the prosecution of the work provided for in the Contract: and
- 3. Pays City all losses, damages, expenses, costs, and attorney’s fees, including appellate proceedings, that City sustains because of a default by Contractor under the Contract: and
- 4. Performs the guarantee of all work and materials furnished under the Contract for the time specified in the Contract, then this bond is void: otherwise it remains in full force.

Any action instituted by City under this bond for payment must be in accordance with the notice and time limitation provisions in Section 255.05(2), Florida Statutes.

Any changes in or under the Contract documents and compliance or noncompliance with any formalities connected with the Contract or the changes does not affect Surety’s obligation under this bond.

IN WITNESS WHEREOF, the said Contractor and Surety have signed and sealed this instrument as follows:

CONTRACTOR

_____ [insert name of principal]

By: _____

_____ Title

(SEAL)

Attachment 14

Date

SURETY

_____ [insert name of surety]

By: _____

(SEAL)

Title

Date

Any Claims under this bond may be addressed to
(name and address of Surety):

Telephone No: _____

Name and address of agent or representative in Florida if different from above:

Telephone No.: _____

Attachment 15

CERTIFICATION REGARDING DEBARMENT, SUSPENSION, AND OTHER RESPONSIBILITY MATTERS
PRIMARY COVERED TRANSACTIONS

This contract is a covered transaction for purposes of 2 C.F.R. pt. 180 and 2 C.F.R. pt. 3000.

The Contractor certifies that, neither the firm nor any person associated therewith in the capacity of owner, partner, director, officer, principal, investigator, project director, manager, auditor, and/or position involving the administration of federal funds:

(a) is presently debarred, suspended, proposed for debarment, declared ineligible, or voluntarily excluded from covered transactions, as defined in 49 CFR s29.110(a), by any federal department or agency;

(b) has within a three-year period preceding this certification been convicted of or had a civil judgment rendered against it for: commission of fraud or a criminal offense in connection with obtaining, attempting to obtain, or performing a federal, state, or local government transaction or public contract; violation of federal or state antitrust statutes; or commission of embezzlement, theft, forgery, bribery, falsification or destruction of records, making false statements, or receiving stolen property;

(c) is presently indicted for or otherwise criminally or civilly charged by a federal, state, or local governmental entity with commission of any of the offenses enumerated in paragraph (b) of this certification; and

(d) has within a three-year period preceding this certification had one or more federal, state, or local government public transactions terminated for cause or default.

The Contractor certifies that it shall not knowingly enter into any transaction with any subcontractor, material supplier, or vendor who is debarred, suspended, declared ineligible, or voluntarily excluded from participation in this project by any federal agency unless authorized by the City of North Port.

The Contractor must comply with 2 C.F.R. pt. 180, subpart C and 2 C.F.R. pt. 3000, subpart C and must include a requirement to comply with these regulations in any lower tier covered transaction it enters into.

This certification is a material representation of fact relied upon by the City of North Port. If it is later determined that the contractor did not comply with 2 C.F.R. pt. 180, subpart C and 2 C.F.R. pt. 3000, subpart C, in addition to remedies available to the City of North Port, the Federal Government may pursue available remedies, including but not limited to suspension and/or debarment.

The bidder or proposer agrees to comply with the requirements of 2 C.F.R. pt. 180, subpart C and 2 C.F.R. pt. 3000, subpart C while this offer is valid and throughout the period of any contract that may arise from this offer.

The Contractor further agrees to include a provision requiring such compliance in its lower tier covered transactions.

Company Name (Contractor)

Tax ID Number

Authorized Representative Name

Authorized Representative Signature

Federal Issued Tax
Identification Number
(If Social Security number DO NOT enter)

CAGE Code issued through www.sam.gov
DATE: _____

Attachment 16

CONTRACT CHANGES

- A. The parties may make changes to the contract work, including additions or deletions, provided that such changes are within the general scope of the contract work. Any change affecting the contract price must be in writing and signed by both parties. The Contractor is not entitled to any increase in price or extension of time unless the contract is changed in accordance with this section.

- B. Either party may submit to the other a change proposal, which must identify any proposed changes in contract price or time, explain why the change is believed necessary, and cite to any applicable provision of the contract. Within a reasonable time, the party receiving the proposal shall respond in writing to the other party. If the parties agree to the change, they will execute an amendment to the contract changing its terms.

- C. Without invalidating the contract, the City may order additions, deletions, or revisions in the work, provided that such changes are within the general scope of the contract work. Such changes may be accomplished by a contract amendment, if the City Commission and Contractor have agreed as to the effect, if any, of the changes on contract price. If the parties cannot agree, the Contractor shall proceed with the work, or, in the case of a deletion, cease activities with respect to the deleted work, subject to the Contractor's right to claim for additional compensation or time. Any such claim must be made in writing within 14 days. Additional compensation will be limited to Contractor's actual cost of the work, plus reasonable profit and overhead. Nothing in this section shall obligate Contractor to undertake work that Contractor reasonably concludes cannot be performed in a manner consistent with Contractor's safety obligations under the contract or governing laws and regulations.

Attachment 17

SANCTIONS AND PENALTIES

In the event of a breach of the terms of this Contract, the Contractor and its subcontractors will be subject to sanctions and penalties as may be imposed and remedies invoked as provided by rule, regulation, or order of the local, state, and federal agency, and as otherwise provided by law and other terms of this Contract.

Attachment 18

TERMINATION FOR CONVENIENCE

The City reserves the right, in its best interest as determined by the City, to cancel this Contract for convenience by giving written notice to the Contractor at least thirty (30) days prior to the effective date of such cancellation. In the event this Contract is terminated for convenience, Contractor shall be paid for any services performed to the City's satisfaction pursuant to the Contract through the termination date specified in the written notice of termination. The Contractor acknowledges and agrees that Contractor has received good, valuable, and sufficient consideration from City, the receipt and adequacy of which are hereby acknowledged by the Contractor, for City's right to terminate this Contract for convenience. The Contractor will not be paid on account of loss of anticipated profits or revenue or other economic loss arising out of or resulting from such termination.

“SAMPLE”

Contract No. 2023-23 (“Contract”) is entered into by and between the City of North Port, Florida, a municipal corporation of the State of Florida (“City”) and _____ [insert name of Organization or other Legal Entity, exactly as name appears in the corporate records at Sunbiz.org], a _____ [insert name of state] _____ [insert type of entity as designated at Sunbiz.org; i.e., “Florida nonprofit corporation”], registered to do business in the State of Florida, whose principal place of business is _____ [insert address] (“Contractor”).

WITNESSETH

NOW THEREFORE, in consideration of the mutual covenants contained herein, and for other good and valuable consideration, the sufficiency and receipt of which are acknowledged, the parties agree as follows:

1. CONTRACT TIMING.

- A. Effective Date. This Contract becomes effective on the date approved by City Commission (“Effective Date”) and terminates upon the completion of the work or as otherwise provided in this Contract.
- B. Time Is of the Essence. Time is of the essence in the performance of this Contract.
 - (1) Notice to Proceed. The Contractor agrees to commence operations within a mutually agreed upon time following written notification by the City to commence work (“Notice to Proceed”).
 - (2) Contract Time. All work performed under the provisions of this Contract must be completed no later than ninety (90) calendar days from the notice to proceed, subject only to delays caused through force majeure. City holidays will be counted as calendar days. The work must be substantially completed no later than sixty (60) calendar days from the notice to proceed, with final completion within thirty (30) calendar days after attaining substantial completion or after delivery to the Contractor of the punch list of items for final completion, whichever is later (“Contract Time”). The Contract Time includes the preparation, submittal, review, and approval of submittals, delivery of materials, and construction, assembly, adjustment, and placement into service for beneficial use of all facilities covered under this Contract.
 - (3) Extensions. Contract Time may be extended due to unforeseen circumstances or unknown site conditions that alter the scope of work only as agreed to in writing by both parties and incorporated into the Contract as a change order or amendment.
- C. Process for Completion.
 - (1) Delivery of Documents Prior to Substantial Completion. Seven (7) calendar days prior to the expiration of the time for substantial completion, the Contractor must deliver to the City the record drawings and all other submittals required in the Contract. After delivery, the City will review the work identified in the Contract, the record drawings, and other submittals, excluding pay requests.
 - (2) Notice. The City must issue a written notice of substantial completion when the City has determined that the work identified in this Contract is substantially complete, and the record drawings are submitted and approved by the City.
 - (3) Punch List.

(a) Development and Delivery. The City will develop the final punch list within two (2) days after delivering the notice of substantial completion. Delivery of the list will not exceed five (5) calendar days after the list has been developed.

(b) Process for Development; Contractor's Response. No later than seven (7) calendar days after delivering the notice of substantial completion, the City will deliver to the Contractor a preliminary punch list and related questions. The punch list must identify the remaining items required to render the construction services complete, satisfactory, and acceptable to the City and for the Contractor to meet its obligations under this Contract. The Contractor must deliver a response to all questions no later than five (5) calendar days after receipt. The City will deliver the final punch list no later than five (5) calendar days after receiving the Contractor's response.

(4) Final Completion. The Contractor must complete the items on the punch list to the satisfaction of the City within the Contract Time and prior to submittal of the application for reduction of retainage or final payment.

2. CONTRACT PRICE.

The Contract Price is _____ [insert value in alphabetical and \$ numerical format; i.e., ONE DOLLAR AND NO/CENTS (\$1.00)] ("Contract Price").

3. CONTRACT DOCUMENTS.

A. Scope and Incorporation of Bid Documents. The work includes repairing the erosion on the east side of FW No. 123 by driving sheet piling, installing weir concrete cap, backfilling the eroded embankment and adding rip rap canal bank revetment. Vibration monitoring and dewatering activities will be required together with sod stabilization of disturbed areas as described in the Request for Bid No. 2023-23 ("RFB"), including plans, drawings, specifications, addenda, permits, diagrams, and other related documents, as well as the Contractor's response to the RFB (collectively, "Contract Documents"). The Contract Documents are specifically made a part of this Contract and are incorporated by reference. In the event of a conflict between or among the documents or any ambiguity or missing specifications or instruction, the following priority is established:

- (1) This Contract and all attachments and exhibits.
- (2) The RFB, including all attachments and addenda.
- (3) The Contractor's response to the solicitation.
- (4) Specific direction from the City Manager or designee.

4. THE CONTRACTOR'S RESPONSIBILITIES.

A. Supervision.

- (1) The Contractor must supervise and direct all work performed to the best of its ability, give the work all the attention necessary for proper supervision and direction, and only employ workers with sufficient skill to perform the job assigned.

- (2) The Contractor assumes full responsibility for all acts, negligence, or omissions of its employees, for those subcontractors and their employees, and for those of all other persons doing work under a contract with the Contractor in furtherance of this Contract.

B. Labor and Materials.

- (1) The Contractor must provide and pay for all labor, materials, and equipment, including tools, construction equipment, and machinery, as well as all transportation and all other facilities and services necessary for the proper completion of the work in strict conformity with the provisions of this Contract and the Contract Documents.
- (2) The Contractor represents and warrants that all equipment and materials used in the work and made a part of the structures or permanently placed in connection with the work, must be new unless otherwise specified in this Contract or Contract Documents, must be of good quality, free of defects, and in conformity with this Contract and related Contract Documents. The Contractor and the City agree that all equipment and materials not in conformity with this Contract are defective.

C. Public Records Law. In accordance with Florida Statutes Section 119.0701, the Contractor must comply with all public records laws, and must specifically:

- (1) Keep and maintain public records required by the City to perform the service.
 - (a) The timeframes and classifications for records retention requirements must be in accordance with the General Records Schedule GS1-SL for State and Local Government Agencies.
(See <http://dos.state.fl.us/library-archives/records-management/general-records-schedules/>)
 - (b) "Public records" means and includes those items specified in Florida Statutes Section 119.011(12), as amended from time to time, and currently defined as: All documents, papers, letters, maps, books, tapes, photographs, films, sound recordings, data processing software, or other material, regardless of the physical form, characteristics, or means of transmission, made, or received pursuant to law or ordinance or in connection with the transaction of official business with the City. The Contractor's records under this Contract include but are not limited to, supplier/subcontractor invoices and contracts, project documents, meeting notes, e-mails and all other documentation generated during the term and in furtherance of this Contract.
- (2) Upon request from the City's custodian of public records, provide the City, at no cost, with a copy of the requested records or allow the records to be inspected or copied within a reasonable time at a cost that does not exceed the cost provided for by law. All records kept electronically must be provided to the City, upon request from the City's custodian of public records, in a format that is compatible with the information technology systems of the City.
- (3) Ensure that project records that are exempt or confidential and exempt from public records disclosure requirements are not disclosed except as authorized by law for the duration of the Contract term and if the Contractor does not transfer the records to the City following completion of the Contract, the Contractor must maintain the project records for the time specified in General Records Schedule GS1-SL for State and Local Government Agencies.
- (4) Upon completion of the Contract, transfer, at no cost to the City, all public records in the Contractor's possession or keep and maintain public records required by the City to perform the service. If the Contractor

transfers all public records to the City upon completion of the Contract, the Contractor must destroy any duplicate public records that are exempt or confidential and exempt from public records disclosure requirements. If the Contractor keeps and maintains public records upon the completion of the Contract, the Contractor must comply with all applicable requirements for retaining public records.

(5) IF THE CONTRACTOR HAS QUESTIONS REGARDING THE APPLICATION OF FLORIDA STATUTES CHAPTER 119 TO THE CONTRACTOR'S DUTY TO PROVIDE PUBLIC RECORDS RELATING TO THIS CONTRACT, CONTACT THE CUSTODIAN OF PUBLIC RECORDS AT: CITY CLERK, 4970 CITY HALL BOULEVARD, NORTH PORT, FLORIDA 34286, 941.429.7063 OR HOTLINE 941.429.7270, publicrecordsrequest@northportfl.gov.

(6) Failure of the Contractor to comply with these requirements constitutes a breach of this Contract. Further, the Contractor may be subject to penalties under Florida Statutes Section 119.10.

- D. Contractor's Affidavit. When all work contemplated by this Contract has been completed and has been inspected and approved by the City or its authorized agent, the Contractor must furnish the City with a Contractor's Affidavit in a form acceptable to the City. Signed affidavits of payment are required from all subcontractors hired by the Contractor, unless payment is approved by the surety in accordance with Florida Statutes Section 255.05(11). The affidavits must state whether the subcontractor(s) have been paid in full or whether there are payments remaining. A list of all subcontractors must be furnished to the City prior to any payments against the Contract.
- E. Subcontractors and Suppliers. All contracts between the Contractor and any subcontractor that the Contractor hires must conform to the provisions of this Contract and the Contract Documents. The Contractor must incorporate the requirements of this Contract in the subcontracts. The Contractor must furnish the City with a list of all subcontractors and suppliers prior to any payments against the Contract. All subcontractors are subject to the City's approval. No change in subcontractors or suppliers will be made without written consent and approval from the City. All subcontractors must comply with Florida Statutes Section 448.095 for registration and use of the E-Verify system operated by the United States Department of Homeland Security.
- F. Licenses and Permits. The Contractor must pay all taxes required by law in connection with the activities done in furtherance of this Contract including sales, use, and similar taxes, and unless otherwise mutually agreed to in writing, must secure all licenses and permits necessary for proper completion of the work, and pay any related fees.
- G. Laws and Regulations. Violation of any local, state, or federal law in the performance of this Contract constitutes a breach of this Contract. The Contractor must comply with all laws, ordinances, rules, regulations, and orders of all public authorities relating to the performance of the work required. If any of the Contract documents are at variance with any law or regulation, the Contractor must notify the City promptly upon discovery.
- H. E-Verify System. During the term of this Contract, the Contractor must be registered with and use the Department of Homeland Security E-Verify System as required by Florida Statutes Section 448.095, Employment Eligibility, including but not limited to verifying the work authorization status of all newly hired employees, and requiring all subcontractors to provide an affidavit attesting that the subcontractor does not employ, contract with, or subcontract with an unauthorized alien. The Contractor must maintain a copy of the affidavit for the duration of the Contract.

5. PAYMENT.

- A. Payment Requests. The Contractor must use a City approved form for all payment requests, along with an updated work schedule reflecting the progress of all work. Payment requests must be accompanied by either written approval and direction of the surety, or receipt of updated affidavits of payment by subcontractors and/or suppliers, in accordance with Florida Statutes Section 255.05(11). The Contractor's payment request must include any changes approved in previous payment requests.
- B. Payment. The Contract Price is net, and all payment requests are payable according to the Florida Local Government Prompt Payment Act (Florida Statutes Section 218.70, *et seq.*). The City or its authorized agent will make payment to the Contractor for all services or work completed or materials furnished in accordance with this Contract only upon certification and approval of the payment request.
- C. Timing of Payments; Retainage. The City will not make payments to the Contractor more frequently than monthly. Payment must be based on the total value of the work completed and accepted during the preceding month, less five percent (5%) retainage. The City must inform the Contractor's surety of any reduction in retainage. Retainage may be reduced upon issuance of the Certificate of substantial completion by the City if, in the sole opinion of the City, sufficient progress on the schedule has been accomplished, all required affidavits have been provided, and the City has retained adequate coverage for the project through the achievement of Final Completion.
- D. Final Payment. The Contractor's submittal for final payment must include the Contractor affidavit, final waiver and release of lien for all subcontractors, materialmen and suppliers, warranty of work, and consent of surety in the forms acceptable to the City. The City's or its authorized agent's approval is required before making final payment for all work, materials, or services furnished under this Contract.

6. LIQUIDATED DAMAGES.

- A. Generally. The work performed must be completed within the Contract Time.
- B. Amount. The City and the Contractor agree that the City will suffer damages if the work is not substantially completed within the Contract Time, plus any extensions allowed by Change Order(s). The parties further agree determining the exact value of the City's damages due to a delay in the substantial completion of the work would be a difficult, time consuming, and costly process. The parties agree that it is in their mutual interest to establish a figure of _____ **[insert value in alphabetical and \$ numerical format; i.e., ONE DOLLAR and NO CENTS (\$1.00)]** as liquidated damages (but not as a penalty) to be paid by the Contractor to the City for each calendar day that substantial completion is delayed beyond the Contract Time.
- C. Adjustments prohibited. The parties agree that neither will make any claim to increase or reduce the amount to be paid under liquidated damages as the result of any calculation of actual damages the City suffered as the result of delay in the substantial completion of the work.

7. BOND REQUIREMENTS.

- A. Performance and Payment Bond. The Contractor must provide a performance and payment bond in the form prescribed in Florida Statutes Section 255.05, in the amount of one hundred percent (100%) of the Contract Price, the costs of which are to be paid by the Contractor. The bond will be acceptable to the City only if the surety company:
 - 1. Is licensed to do business in the State of Florida;
 - 2. Holds a certificate of authority authorizing it to write surety bonds in the State of Florida;

3. Has twice the minimum surplus and capital required by the Florida Insurance Code at the time the invitation to bid is issued;
 4. Is otherwise in compliance with the provisions of the Florida Insurance Code;
 5. Holds a currently valid certificate of authority issued by the United States Department of Treasury under 31 U.S.C. §§ 9304-9308;
 6. Has a current rating of at least Excellent (A or A-) as reported in the most current Best Key Rating Guide, published by A.M. Best Company, Inc., of 75 Fulton Street, New York, New York 10038; and
 7. Has an underwriting limitation of at least two times the dollar amount of the Contract Price.
- B. Substitute Bond Required. If the surety company for any bond furnished by the Contractor files for bankruptcy, has a receiver appointed, is declared bankrupt, becomes insolvent, has an assignment made for the benefit of creditors, has its right to do business terminated in the State of Florida, or ceases to meet the requirements imposed by this Contract, the Contractor must, within five (5) calendar days thereafter, substitute another bond and surety company, both of which are subject to the City's approval.
- C. Surety Acceptance of Terms. The Contractor warrants that the Contractor delivered this Contract to the surety prior to execution of the bond, and that the surety company acknowledged that it has read the surety qualifications and surety obligations imposed by this Contract and satisfies all conditions.
- D. Delivery of the Bond. The Contractor must provide the required performance and payment bond to the City within ten (10) calendar days of the Effective Date. The Contractor's failure to provide the bond timely constitutes a default. Pursuant to Section 2-404 of the Code of City of North Port, Florida, upon default, the City may immediately award the bid to the next lowest responsive and responsible bidder and recover from the Contractor the difference in cost between the original winning bid and the next lowest responsive and responsible bidder. The default is only curable at the option of the City.
- E. Recording the Bond. The Contractor is responsible and bears all costs associated with recording the required bond or security with the Sarasota County Clerk of the Circuit Court. The Contractor must furnish the receipt for and certified copy of the recorded bond to the Purchasing Division at the time of the pre-construction meeting. The default is only curable at the option of the City.

8. CONTRACTOR'S INSURANCE.

A. Insurance.

- (1) Before performing any work, the Contractor and subcontractors must procure and maintain during the Contract Time the insurance identified in this Section 8 against all claims of injury to persons or damage to property which may arise from or in connection with its performance of the Contract work, unless otherwise specified. The insurance policies must remain in full force and effect until their obligations and warranty periods have been discharged or satisfied.
- (2) The policies of insurance must be primary and written on forms acceptable to the City, placed with insurance carriers approved and licensed by the State of Florida Department of Financial Services, and meet a minimum financial A.M. Best and Company, Inc. rating of no less than "A – Excellent: FSC VII."

- (3) The City Manager or designee may alter the amounts or types of insurance policies required by this Contract upon written agreement with the Contractor.
 - (4) Proof of insurance must be filed by the Contractor with the City within ten (10) calendar days after the Effective Date of this Contract.
 - (5) These insurance requirements are minimum requirements and in no way limit the indemnity covenants contained in this Contract. The City in no way warrants that the minimum limits are sufficient to protect the Contractor from liabilities that might arise out of the performance of the work done by the Contractor, its agents, representatives, employees, or subcontractors. The Contractor is free to purchase additional insurance as it may determine necessary. The extent of the Contractor's liability for indemnity of the City must not be limited by insurance coverage or lack thereof, or unreasonably delayed for any reason, including but not limited to, insurance coverage disputes between the Contractor and its carrier.
- B. Workers' Compensation and Employers' Liability Insurance. Coverage pursuant to Florida Statutes, Chapter 440 must apply to all employees at the statutory limits provided by state and federal laws. The policy must include Employers' Liability with a limit of \$1,000,000 for each accident; \$1,000,000 for each employee; and \$1,000,000 policy limit for bodily injury or disease.
- C. Comprehensive Commercial General Liability Insurance. A comprehensive commercial general liability policy, including but not limited to bodily injury, property damage, broad form contractual liability and Explosion, Collapse and Underground (XCU) coverage.
- (1) The general aggregate limit must apply separately to this Contract, or the general aggregate limit must be twice the required occurrence limit.
 - (2) The policy must include General Liability with a limit of \$1,000,000 for general aggregate; \$1,000,000 for each occurrence; \$1,000,000 for products and completed operations; \$100,000 for damage to rented premises; and \$100,000 for fire damage.
- D. Automobile Liability Insurance. Automobile liability insurance to include all owned, leased, hired, and non-owned vehicles.
- (1) Automobile liability insurance must be written on a standard ISO form (CA 00 01) covering any auto (Code 1), or if the Contractor has no owned autos, hired (Code 8) and non-owned (Code 9) autos.
 - (2) The policy must include liability insurance with a limit of \$1,000,000 for Combined Single Limit (CSL) for each accident; \$1,000,000 per person for bodily injury; \$1,000,000 per accident for bodily injury; and \$1,000,000 per accident for property damage.
- E. Other Insurance. Other insurance is only required if checked below. If not checked, the referenced insurance is not required.
- Builder's Risk Insurance for the Course of Construction or Installation Floater Insurance. The policy must include the "All Risk" (Special Perils) coverage with limits equal to the completed value of the project; and must not include coinsurance penalty provisions.
 - Contractor's Pollution Legal Liability for Projects Involving Environmental Hazards. The policy must include

liability insurance with a limit of \$1,000,000 for each occurrence or claim and \$2,000,000 for policy aggregate.

[] Environmental/Pollution Liability. Required when chemicals being used are listed as “hazardous” on www.epa.gov website. The Environmental/Pollution Liability policy must include a limit of \$500,000 general aggregate, and \$500,000 each occurrence. The Contractor must notify the City prior to usage of hazardous chemicals so that adequate insurance coverage is provided prior to use. Failure to notify the City shall be deemed a material breach of this Contract.

F. Waiver of Subrogation. All required insurance policies, except for Workers’ Compensation, are to be endorsed with a Waiver of Subrogation. The insurance companies, by proper endorsement or through other means, must agree to waive all rights of subrogation against the City, its Commissioners, officers, officials, employees, volunteers, and the City’s insurance carriers, for losses paid under the terms of these policies that arise from the contractual relationship or work performed by the Contractor for the City. It is the Contractor’s responsibility to notify its insurance company of the Waiver of Subrogation and request written authorization or the proper endorsement. ADDITIONALLY, THE CONTRACTOR, ITS OFFICERS, OFFICIALS, AGENTS, EMPLOYEES, VOLUNTEERS, AND ANY SUBCONTRACTORS, AGREE TO WAIVE ALL RIGHTS OF SUBROGATION AGAINST THE CITY AND ITS INSURANCE CARRIERS FOR ANY LOSSES PAID, SUSTAINED, OR INCURRED, BUT NOT COVERED BY INSURANCE, THAT ARISE FROM THE CONTRACTUAL RELATIONSHIP OR WORK PERFORMED. THIS WAIVER APPLIES TO ANY DEDUCTIBLES OR SELF-INSURED RETENTIONS FOR WHICH THE CONTRACTOR OR ITS AGENTS MAY BE RESPONSIBLE.

G. Policy Form.

(1) All policies required by this Contract, except for Workers’ Compensation, or unless specific approval is given by Risk Management through the City’s Purchasing Division, are to be written on an occurrence basis, and must name the City of North Port, Florida, its Commissioners, officers, agents, employees, and volunteers as additional insured as their interest may appear under this Contract. Claims made policies may be accepted for professional liability, hazardous materials and other risks as are authorized by the City’s Purchasing Division. All claims made policies contributing to the satisfaction of the insurance requirements must have an extended reporting period option or automatic coverage of not less than two (2) years. If provided as an option, the Contractor must purchase the extended reporting period on cancellation or termination unless a new policy is affected with a retroactive date, including at least the last policy year.

(2) Insurance requirements itemized in this Contract, and required of the Contractor, must be provided by or on behalf of all subcontractors to cover their operations performed under this Contract. The Contractor is responsible for any modifications, deviations, or omissions in these insurance requirements as they apply to its subcontractors.

(3) Each insurance policy required by this Contract must:

(a) Apply separately to each insured against whom claim is made and suit is brought, except with respect to limits of the insurer’s liability.

(b) Be endorsed to state that coverage must not be suspended, voided, or cancelled by either party except after notice is delivered in accordance with the policy provisions. The Contractor is to notify the City’s Purchasing Division of any occurrence by written notice via certified mail, return receipt requested.

(4) The City retains the right to review, at any time, coverage, form, and amount of insurance.

- (5) The Contractor is solely responsible for payment of all premiums for insurance required in this Contract and is solely responsible for the payment of all deductibles, SIR (self-insured retentions), any loss or portion of any loss that is not covered by any available insurance policy, and retention as set forth in the policies, whether the City is an insured under the policy. The Contractor's insurance is considered primary for any loss, regardless of any insurance maintained by the City.
- (6) All certificates of insurance must be approved by the City before commencement of any work. All required certificates of insurance must be accompanied by a copy of the additionally insured documents/endorsements (CG 20101185 or combination of CG 2010370704 and CG 20370704). Certificates of insurance evidencing claims made or occurrences form coverage and conditions to this Contract, as well as the contract number and description of work, are to be furnished to the City's Purchasing Division at 4970 City Hall Boulevard, Suite 337, North Port, FL 34286 prior to commencement of the work and a minimum of thirty (30) calendar days prior to expiration of the insurance contract when applicable. The certificate of insurance issued by the underwriting department of the insurance carrier must certify compliance with the insurance requirements of this Contract. No changes may be made to these specifications without prior written approval by the City Manager or designee.
- H. Notices. Notices of Accidents (Occurrences) and Notices of Claims associated with work being performed must be provided to the Contractor's insurer(s) and the City's Purchasing Division as soon as practicable after notice to the insured Contractor.

9. INDEMNITY, DEFENSE, AND RELEASE.

- A. **TO THE EXTENT PERMITTED BY FLORIDA LAW, THE CONTRACTOR ASSUMES ALL LIABILITY FOR, AND RELEASES AND AGREES TO DEFEND, INDEMNIFY, PROTECT, AND HOLD HARMLESS THE CITY, ITS COMMISSIONERS, OFFICERS, AGENTS AND EMPLOYEES, FROM ALL LIABILITIES, FINES, CLAIMS, ASSESSMENTS, SUITS, JUDGMENTS, DAMAGES, LOSSES AND COSTS, INCLUDING CONSEQUENTIAL, SPECIAL, INDIRECT, AND PUNITIVE DAMAGES, (INCLUDING, BUT NOT LIMITED TO, REASONABLE ATTORNEYS' FEES AND COURT COSTS, WHETHER THE FEES AND COSTS ARE INCURRED IN NEGOTIATIONS, AT THE TRIAL LEVEL OR ON APPEAL, OR IN THE COLLECTION OF ATTORNEYS' FEES), ARISING OUT OF ANY ACTS, ACTIONS, BREACHES, NEGLIGENCE OR OMISSIONS OF THE CONTRACTOR, OR THE CONTRACTOR'S OFFICERS, EMPLOYEES, AGENTS, SUB-CONTRACTORS, SUB-CONSULTANTS, AND OTHER PERSONS EMPLOYED OR UTILIZED BY THE CONTRACTOR IN THE PERFORMANCE OF, OR THE FAILURE TO PERFORM, THIS CONTRACT. THIS CONTRACT DOES NOT CONSTITUTE A WAIVER OF SOVEREIGN IMMUNITY OR CONSENT BY THE CITY OR ITS SUBDIVISIONS TO SUIT BY THIRD PARTIES.**
- B. **FURTHER, THE CONTRACTOR MUST FULLY INDEMNIFY, DEFEND, AND HOLD HARMLESS THE CITY OF NORTH PORT, FLORIDA, FROM ANY SUITS, ACTIONS, DAMAGES, AND COSTS OF EVERY NAME AND DESCRIPTION, INCLUDING ATTORNEYS' FEES, ARISING FROM, OR RELATING TO VIOLATION OR INFRINGEMENT OF A TRADEMARK, COPYRIGHT, PATENT, TRADE SECRET, OR INTELLECTUAL PROPERTY RIGHT.**
- C. The City must provide all available information and assistance that the Contractor may reasonably require regarding any claim. In the event of a claim, the City must promptly notify the Contractor in writing by prepaid certified mail (return receipt requested) or by delivery through any nationally recognized courier service (Federal Express, UPS, USPS, or others) which provides evidence of delivery, at the address provided for receipt of notices in this Contract.
- D. The insurance coverage and limits required in this Contract may or may not be adequate to protect the City and the insurance coverage must not be deemed a limitation on the Contractor's liability under the indemnity provided in this section. In any proceedings between the parties arising out of or related to this indemnity provision, the

prevailing party must be reimbursed all costs, expenses, and reasonable attorney fees through all proceedings (at both trial and appellate levels).

- E. This Contract must not be deemed to affect the rights, privileges, and immunities of the City as set forth in Florida Statutes Section 768.28.
- F. The terms of this section survive the termination or completion of this Contract.

10. TERMINATION.

- A. Termination With or Without Cause. The City Manager or designee may terminate the work under this Contract with or without cause, in whole or in part, whenever the City Manager or designee determines that termination is in the City's best interest.
 - (1) Any termination must be effective by delivery to the Contractor of a written notice of termination at least thirty (30) calendar days before the date of termination, specifying the extent to which performance of the work is terminated and the date upon which the termination becomes effective.
 - (2) Except as otherwise directed, the Contractor must cease all work on the date of receipt of the notice of termination or other date specified in the notice; place no further orders or subcontracts for materials, services, or facilities except as necessary for completion of the portion of the work not terminated; terminate all vendors and subcontracts; and settle all outstanding liabilities and claims.
 - (3) The Contractor must deliver to the City all documents (including but not limited to reports, designs, specifications, and all other data) prepared or obtained by the Contractor in connection with its services.
 - (4) The City must pay the Contractor in full settlement of all claims by it hereunder as the work actually completed bears to the entire work under this Contract, as determined by the City, less payments already made to the Contractor, and any amounts withheld by the City to settle claims or to pay indebtedness of the Contractor in accordance with the provisions of this Contract. The City has no obligation under any circumstance to make any payment to the Contractor for services that have not been performed or that are performed after the termination date.
- B. Termination for Non-Appropriation. The parties acknowledge and agree that the financial obligations of the City in this Contract, or any subsequent contract entered into or referenced when the City is a party, are subject to the provisions of Florida Statutes Section 166.241, as amended, regardless of whether a particular obligation has been expressly so conditioned. Since funds are appropriated annually by the City Commission on a fiscal year basis, the City's legal liability for the payment of any costs must not arise unless and until appropriations for the costs are approved for the applicable fiscal year by the City Commission; nor will liability arise if a request for the appropriations is excluded from the budget approved by the City Commission. Notwithstanding the foregoing, no Commissioner, officer, employee, director, member or other natural person or agent of the City will have any personal liability in connection with a breach of the provisions of this Section or in the event of a default by the City under this Section. This Contract does not constitute an indebtedness of the City nor an obligation of the City to levy or pledge any form of taxation nor an obligation for which the City has levied or pledged any form of taxation.
- C. Termination for Abandonment. If the Contractor abandons performance under this Contract, the City Manager or designee may terminate this Contract upon three (3) calendar days' written notice to the Contractor indicating the intention to do so. The written notice must state the evidence indicating the Contractor's abandonment.

- D. Contractor's Termination. The Contractor may terminate this Contract only in the event of the City failing to pay the Contractor's properly documented and submitted payment request within ninety (90) calendar days of the approval by the City's Administrative Agent, or if the project is suspended by the City for a period greater than ninety (90) calendar days.
- E. Court Proceedings. The City Manager or designee reserves the right to terminate this Contract in the event the Contractor is placed in either voluntary or involuntary bankruptcy, a receiver is appointed for the Contractor, or an assignment is made for the benefit of creditors.
- F. Breach. In the event the Contractor is in breach of this Contract, the City must provide written notice of the breach and the Contractor will have ten (10) calendar days to cure, calculated from the date the Contractor receives the notice. If the Contractor fails to cure within the ten (10) calendar days, the City Manager or designee may immediately terminate the Contract and/or refuse to make any additional payment, in whole or in part, and may demand the return of a portion or the entire amount previously paid to the Contractor due to:
- (1) The quality of a portion or all the Contractor's work not being in accordance with the requirements of this Contract;
 - (2) The quantity of the Contractor's work not being as represented in the Contractor's payment request, or otherwise;
 - (3) The Contractor's rate of progress is, in the City's opinion, whether substantial or final completion, or both, inexcusably delayed;
 - (4) The Contractor's failure to pay the Contractor's project related obligations including, but not limited to, subcontractors, laborers, materialmen, equipment, and other suppliers;
 - (5) Claims made, or likely to be made, against the City or its property;
 - (6) Loss caused by the Contractor;
 - (7) The Contractor's failure or refusal to perform any of the obligations to the City, after written notice and a reasonable opportunity to cure, as set forth above; or
 - (8) Violation of any local, state, or federal law in the performance of this Contract constitutes a breach of this Contract.
- G. Waiver. Any delay or failure to enforce any breach of this Contract by either the City or the Contractor will not be binding upon the waiving party unless the waiver is in writing. In the event of a written waiver, the waiver will not affect the waiving party's rights with respect to any other or further breach. The making or acceptance of a payment by either party with knowledge of the existence of a default or breach must not operate or be construed to operate as a waiver of any subsequent default or breach.
- H. Payment Adjustments. If the City makes written demand upon the Contractor for amounts previously paid by the City, the Contractor must promptly comply with the demand. The City's rights hereunder survive the term of this Contract and are not waived by final payment and/or acceptance.
- I. E-Verify Violation.

- (1) If the City has a good faith belief that the Contractor has knowingly violated Florida Statutes Section 448.09(1), then this Contract may be terminated by the City.
- (2) If the City has a good faith belief that a subcontractor has knowingly violated Florida Statutes Section 448.09(1), but the Contractor has otherwise complied, then the City must promptly notify the Contractor and order the Contractor to immediately terminate this Contract with the subcontractor.
- (3) The Contractor must comply with Florida Statutes Section 448.095(2) for any challenge to termination of this Contract under this Section.

J. Remedies. In the event of a default or breach of the Contract terms, the City may avail itself of every remedy specifically given to it now existing at law or in equity, and every remedy must be in addition to every other remedy so specifically given or otherwise so existing and may be exercised from time to time and as often and in the order as may be deemed expedient by the City. The exercise, or the beginning of the exercise, of one remedy must not be deemed to be a waiver of the right to exercise, at the same time or thereafter, any other remedy. The City's rights and remedies as set forth in this Contract are not exclusive and are in addition to any other rights and remedies available to it in law or in equity.

11. EQUAL EMPLOYMENT OPPORTUNITY.

The City of North Port, Florida, consistent with the provisions of Title VII of the Civil Rights Act of 1964 ("Title VII") and the regulations issued pursuant to Title VII and Florida Statutes Section 287.09451, states that in any contract entered into pursuant to the advertisement, minority business enterprises will be afforded full opportunity to submit replies in response to the advertisement and will not be discriminated against on the grounds of race, color or national origin in consideration for an award.

12. NOTICES.

Any notice, demand, communication, or request required or permitted by this Contract must be sent by certified mail, return receipt requested, or by delivery through any nationally recognized courier service (Federal Express, UPS, USPS, and others) that provides evidence of delivery, at the address provided for receipt of notices in this Contract and e-mailed to:

As to the City: Elizaebth Wong, Project Manager
 City of North Port
 Department of Public Works
 1100 N. Chamberlain Boulevard
 North Port, Florida 34286
 (941)240-8321
 ewong@northportfl.gov

With copies of claims and demands sent to: City of North Port, Florida
 City Attorney's Office
 4970 City Hall Boulevard
 North Port, Florida 34286
 northportcityattorney@northportfl.gov

As to Contractor: _____ [insert name of Contractor]
_____ [insert name of person signing]
_____ [insert address]
_____ [insert city, state, and zip code]
_____ [insert telephone]
_____ [insert email address]

Notices are effective when received at the addresses specified above. Changes to the respective addresses may be made from time to time by either party by written notice. This Section must not be construed to restrict the transmission of routine communications between representatives of the Contractor and the City.

13. ATTORNEYS' FEES.

In any proceedings between the parties arising out of or related to this Contract, the prevailing party must be reimbursed all costs, expenses, and reasonable attorneys' fees through all proceedings, at both trial and appellate levels.

14. SCRUTINIZED COMPANIES.

- A. Certification. As required by Florida Statutes Section 287.135(2), for contracts of any amount, the Contractor must certify on a form provided by the City, that it is not on the Scrutinized Companies that Boycott Israel List, created pursuant to Florida Statutes Section 215.4725, and that it is not engaged in a boycott of Israel.
- B. Requirements. As required by Florida Statutes Section 287.135(5), for contracts of \$1,000,000 or more, the Contractor must certify on a form provided by the City, that all of the following are true:
 - (1) The Contractor is not on the Scrutinized Companies that Boycott Israel List, created pursuant to Florida Statutes Section 215.4725, and that it is not engaged in a boycott of Israel; and
 - (2) The Contractor is not on the Scrutinized Companies with Activities in Sudan list or the Scrutinized Companies with Activities in Iran Petroleum Energy Sector list, created pursuant to Florida Statutes Section 215.473; and
 - (3) The Contractor is not engaged in business operations in Cuba or Syria.
- C. Termination. If the Contractor provides a false certification or has been placed on one of the above-noted Lists of Scrutinized Companies or has engaged in business operations in Cuba or Syria, the Contractor will be in breach of this Contract and the City may terminate this Contract.
- D. Penalty.
 - (1) A Contractor that has been found to have provided a false certification may be subject to a civil penalty equal to the greater of \$2 million or twice the amount of this Contract, plus all reasonable attorneys' fees and costs, including any costs for investigations that led to the finding of the false certification; and
 - (2) Will be ineligible to bid on any contract with the City for three (3) years after the date the City determined that the Contractor submitted a false certification.

15. FORCE MAJEURE.

- A. Should performance of any obligation created under this Contract become illegal or impossible by reason of:
- (1) A strike or work stoppage, unless caused by a negligent act or omission of either party;
 - (2) An act of God, tornado, hurricane, flood, sinkhole, fire, explosion, landslide, earthquake, epidemic, pandemic, quarantine, pestilence, or extremely abnormal and excessively inclement weather;
 - (3) An act of a public enemy, act of war, terrorism, effect of nuclear radiation, blockage, insurrection, riot, civil disturbance, state of martial law, or national or international calamity;
 - (4) A declared emergency of the federal, state, or local government; or
 - (5) Any other like event that is beyond the reasonable control of the non-performing party;
- then the performance of the obligation is suspended during the period of, and only to the extent of, the prevention or hindrance, provided that:
- (6) The non-performing party provides written notice within five (5) calendar days of the event of *force majeure*, describing the event in sufficient detail, including but not limited to: the nature of the occurrence, a good faith estimate of the duration of the delay, proof of how the event has precluded the non-performing party from performing, and the means and methods for correcting the delay; and continues to furnish timely reports of all actions required for it to commence or resume performance of its obligations under this Contract;
 - (7) The excuse of performance is no greater in scope or duration than required by the event of *force majeure*;
 8. No obligations of either party that arose before the *force majeure* are excused as a result of the event of *force majeure*; and
 9. The non-performing party uses all reasonable diligence to remedy its inability to perform.
- B. Economic hardship of a party does not constitute an event of *force majeure*. A party must not be excused from performance due to forces that it could have reasonably prevented, removed, or remediated prior to, during, or immediately after their occurrence.
- C. The non-performing party's affected obligations under this Contract will be temporarily suspended during, but not longer than, the continuance of the event of *force majeure* and a reasonable time thereafter as may be required to commence or resume performance of its obligations. Notwithstanding the above, performance will not be excused under this Section for a period exceeding two (2) consecutive months, provided that in extenuating circumstances, the City may excuse performance for a longer term.
- D. The term of this Contract will be extended by a period equal to that during which the non-performing party's performance is suspended under this Section.

16. MISCELLANEOUS.

- A. Authority to Execute. The signature by any person to this Contract will be deemed a personal warranty that the person has the full power and authority to bind any corporation, partnership, or any other business or governmental entity for which the person purports to act hereunder.
- B. Binding Effect/Counterparts. By the signatures affixed hereto, the parties intend to be bound by the terms and conditions hereof. This Contract is binding upon and will inure to the benefit of the parties and their respective heirs, executors, administrators, successors, and assigns. It may be signed in counterparts.
- C. Governing Law and Venue. The laws of the State of Florida govern the rights, obligations, and remedies of the parties under this Contract. The exclusive venues for any legal or judicial proceedings in connection with the enforcement or interpretation of this Contract are the Circuit Court of the Twelfth Judicial Circuit in and for Sarasota County, Florida, and the United States District Court for the Middle District of Florida.
- D. No Agency. Nothing contained herein must be deemed or construed as creating the relationship of principal and agent, or of partnership or joint venture, between the parties, it being understood and agreed that no provision, or any acts of the parties will be deemed to create any relationship between them other than that as detailed.
- E. Severability. In the event any court holds any provision of this Contract to be illegal, invalid, or unenforceable, the remaining provisions must be valid and binding upon the parties. One or more waivers by either party of any breach of any provision, term, condition, or covenant must not be construed as a waiver of a subsequent breach by the other party.
- F. Headings. The descriptive titles appearing in each respective paragraph are for convenience only and are not a part of this Contract and do not affect its construction.
- G. Complete Contract. This Contract incorporates and includes all prior negotiations, correspondence, agreements, or understandings between the parties, and the parties agree that there are no commitments, agreements, or understandings concerning the subject matter of this Contract that are not contained in this document. This Contract supersedes all other agreements between the parties, whether oral or written, with respect to the subject matter.
- H. Amendment. No amendment, change, or addendum to this Contract is enforceable unless agreed to in writing by both parties and incorporated into this Contract. Any amendments changing the City's financial obligations under this Contract will require approval by the City Commission. The City Commission hereby authorizes the City Manager or designee to approve and execute all Contract amendments on behalf of the City that do not change the City's financial obligations under this Contract.
- I. Assignment. The Contractor must not assign this Contract or any right or responsibility without the written consent of the City.
- J. Non-Discrimination. The City of North Port, Florida does not discriminate on the basis of race, color, national origin, sex, age, disability, family, or religious status in administration of its programs, activities, or services. The Contractor must not administer this Contract in an unlawfully discriminatory manner, nor deny participation in or the benefits of same to any individual based on that individual's race, color, national origin, sex, age, disability, family or religious status, marital status, sexual orientation, gender identity or expression, or physical characteristic.

17. SUPPLEMENTAL DOCUMENTS - The following supplemental documents are attached and incorporated fully as part of this Contract.

ATTACHMENT 1.1: Insurance

(N/A) ATTACHMENT 1.2: Professional Liability

(N/A) ATTACHMENT 1.3: Environmental and Pollution Liability

(N/A) ATTACHMENT 1.4: Builder's Risk

(N/A) ATTACHMENT 2.1: Indemnity Terms - General

ATTACHMENT 2.2: Indemnification – Construction

ATTACHMENT 3: FEMA Provisions

(N/A) ATTACHMENT 4: Davis Bacon – Min Wage Rate

ATTACHMENT 5: Certification Regarding Lobbying

ATTACHMENT 6: Non-Collusive Affidavit

ATTACHMENT 7: Conflict of Interest Form

ATTACHMENT 8: Public Entity Crime Information

ATTACHMENT 9: Drug-Free Workplace Form

ATTACHMENT 10: The Florida Trench Safety Act

ATTACHMENT 11: Scrutinized Company Certification Form

ATTACHMENT 12: Vendor's Certification For E-Verify System

ATTACHMENT 13: Performance and Payment Bond Terms

ATTACHMENT 14: Performance and Payment Bond Requirements and Form

ATTACHMENT 15: Debarment Form

ATTACHMENT 16: Contract Changes

ATTACHMENT 17: Sanctions and Penalties

ATTACHMENT 18: Termination for Convenience

IN WITNESS WHEREOF, the parties have executed this Contract on the dates as indicated below.

CONTRACTOR

_____ [insert name of legal entity as reflected in Sunbiz.org]

By: _____
_____ [Insert name of authorized agent as reflected in Sunbiz.org]
_____ [insert title of authorized agent as reflected in Sunbiz.org]

ACKNOWLEDGEMENT

STATE OF _____
COUNTY OF _____

The foregoing instrument was acknowledged before me by means of physical presence or online notarization, on this _____ day of _____ 20____, by _____ [insert person's name] as _____ [insert title] for [insert Contractor's name].

Notary Public

___ Personally Known OR ___ Produced Identification
Type of Identification Produced _____

Approved by the City Commission of the City of North Port, Florida on _____, 2023. **[insert date]**.

IN WITNESS WHEREOF, the parties have executed the Contract as of the date first above written.

APPROVED by the City Commission of the City of North Port, Florida on _____, 2023.

CITY OF NORTH PORT, FLORIDA

A. Jerome Fletcher II, ICMA-CM, MPA
City Manager

ATTEST

Heather Faust, MMC
City Clerk

APPROVED AS TO FORM AND CORRECTNESS

Amber L. Slayton, B.C.S.
City Attorney

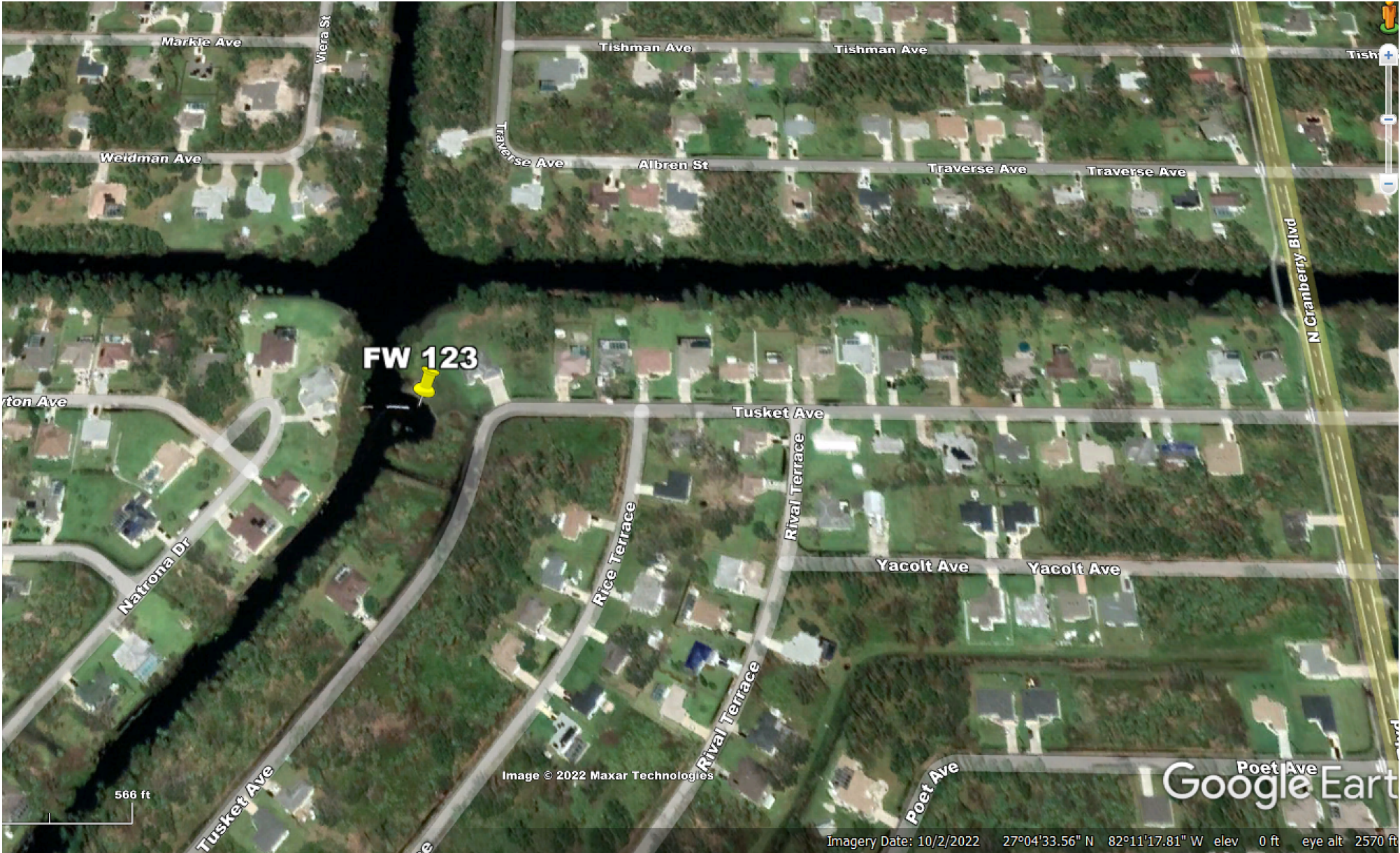

FW 123

566 ft

Image © 2022 Maxar Technologies

Google Earth

Imagery Date: 10/2/2022 27°04'33.56" N 82°11'17.81" W elev 0 ft eye alt 2570 ft

FIXED WEIR 123 EROSION REPAIR CITY OF NORTH PORT

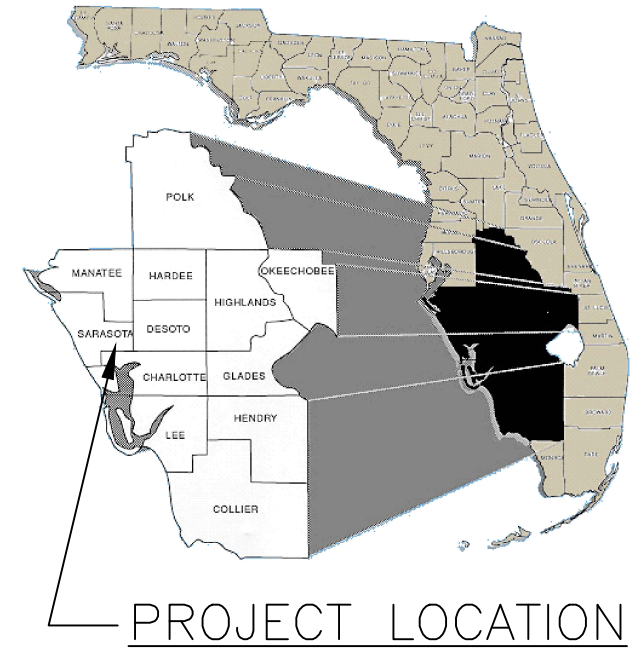

INDEX OF SHEETS

Sheet No.	Description
1	Cover Sheet with Index of Sheets
2	Existing Conditions
3	Proposed Plan
4	Details and Notes

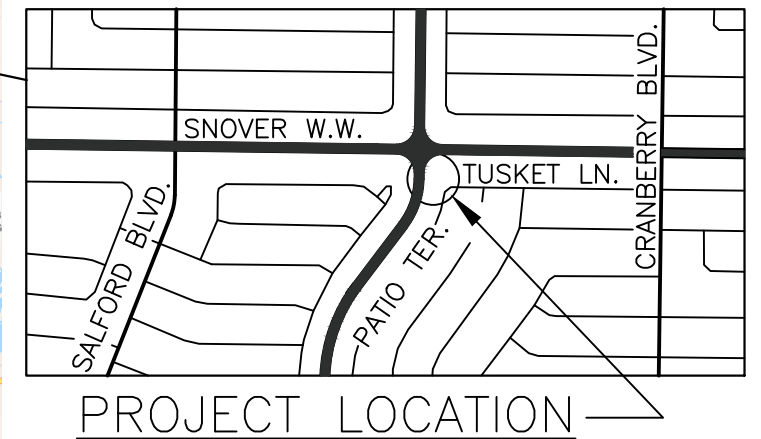
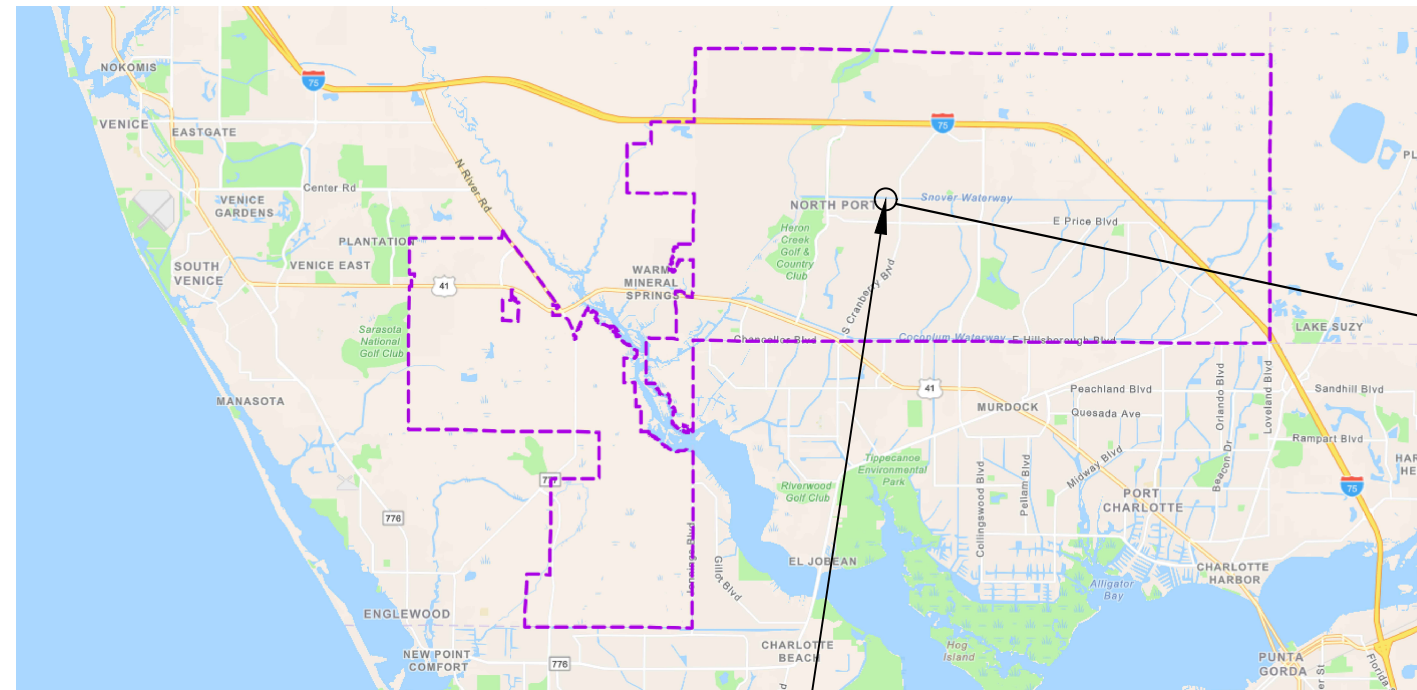

PROJECT LOCATION

Lots 21 and 22, Blk 403, 9th Add. to Port Charlotte
Patio Terrace, North Port, FL 34286

Revisions:

Date	Description



FIXED WEIR 123 EROSION REPAIR

City of North Port | Sarasota County, Florida
4970 City Hall Blvd., North Port, FL 34286

Drawn By: AMF

Date: 12/21/2022

Sheet 1 of 4

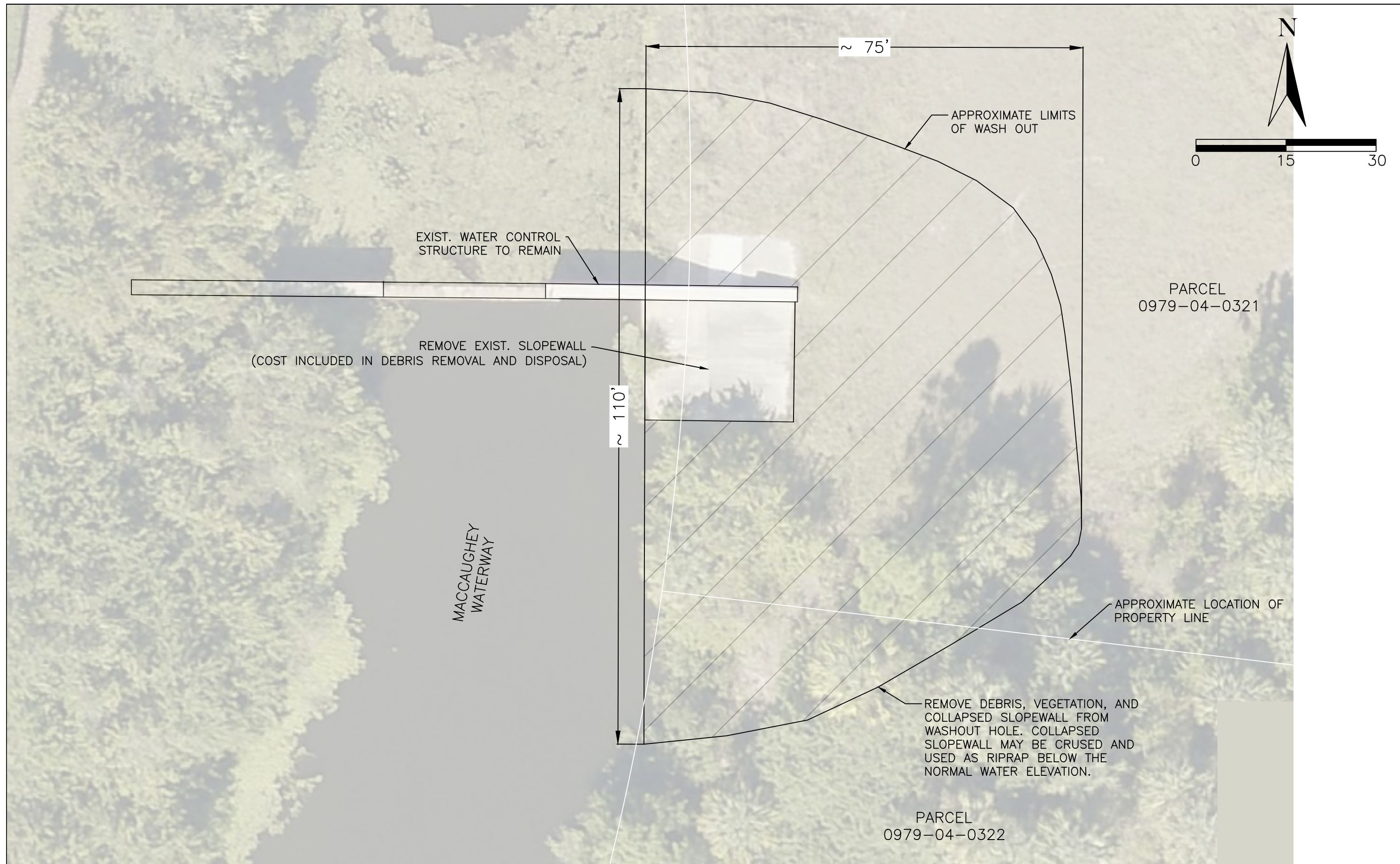

FIXED WEIR 123 EROSION REPAIR
EXISTING CONDITIONS

City of North Port | Sarasota County, Florida
4970 City Hall Blvd., North Port, FL 34286

Drawn By: AMF

Date: 12/21/2022

Scale: 1"=15'

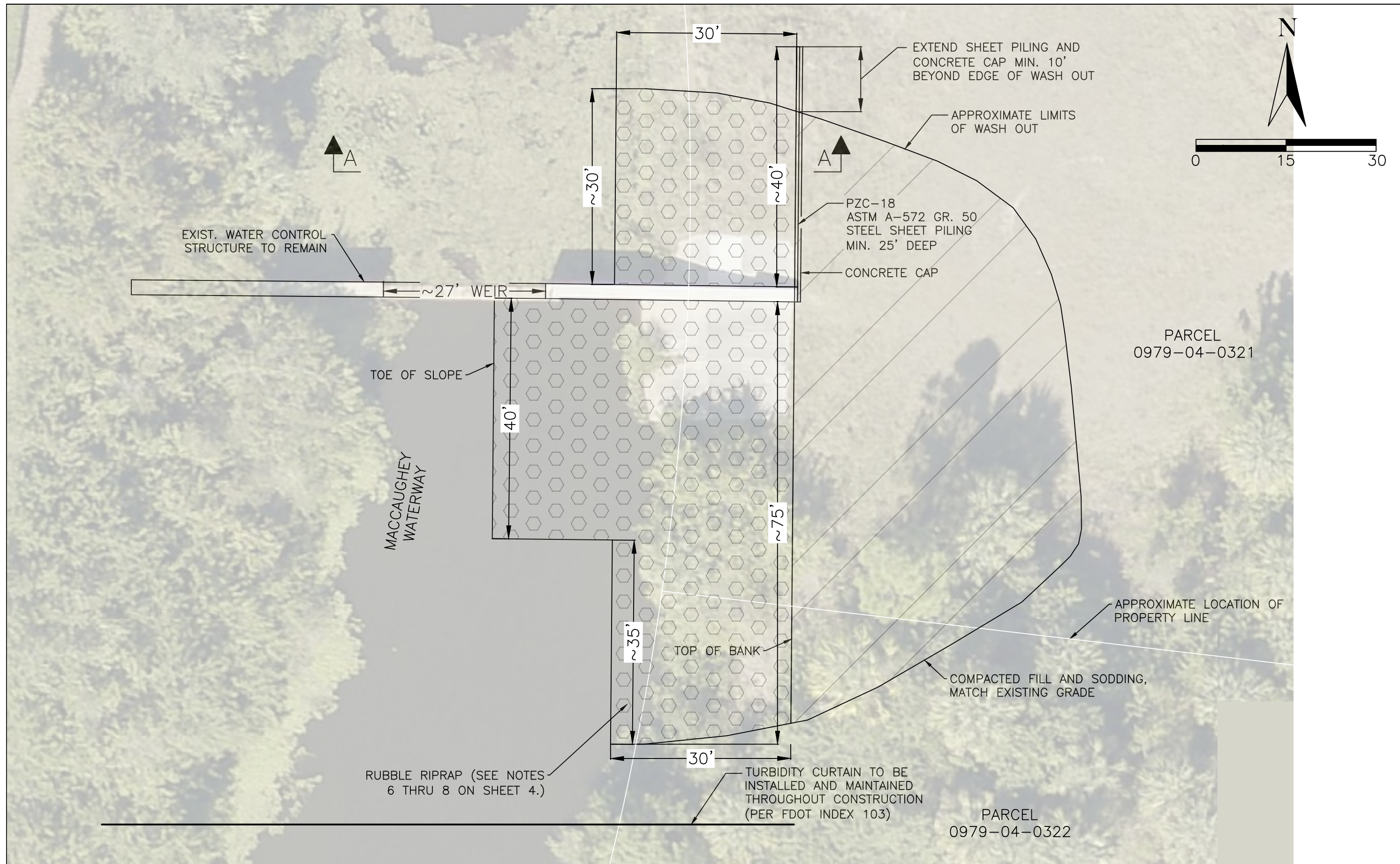

FIXED WEIR 123 EROSION REPAIR
PROPOSED PLAN

City of North Port | Sarasota County, Florida
4970 City Hall Blvd., North Port, FL 34286

Drawn By: AMF

Date: 12/21/2022

Scale: 1"=15'

Sheet 3 of 4

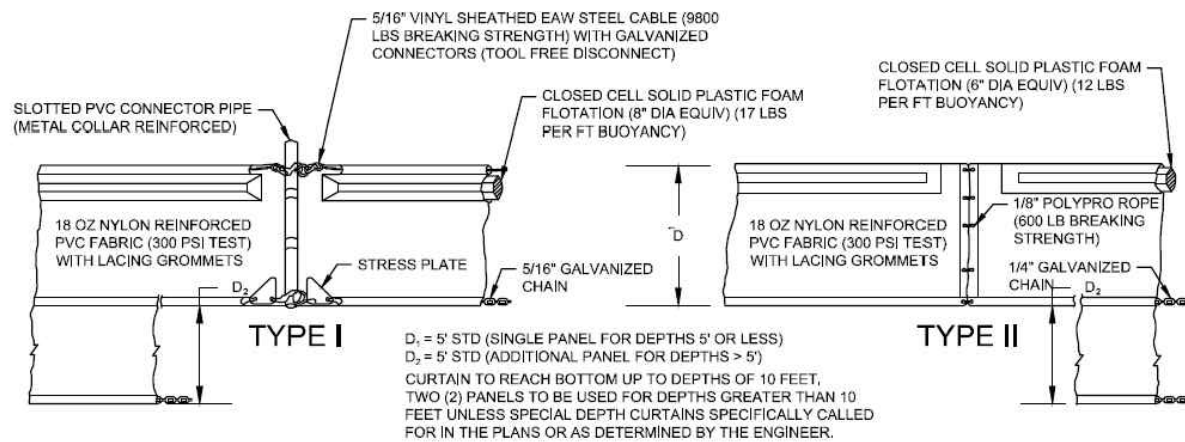
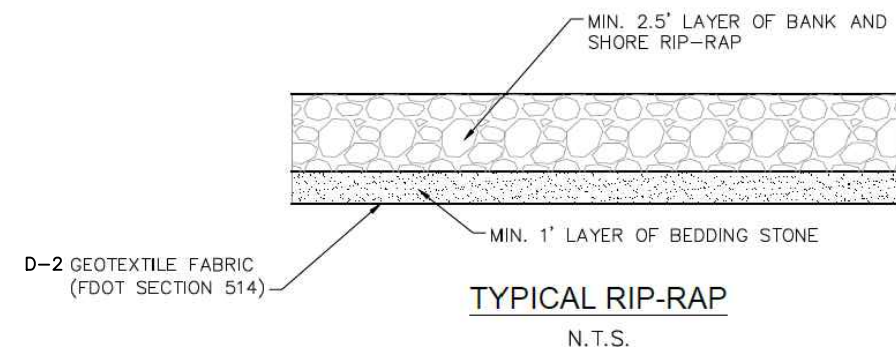
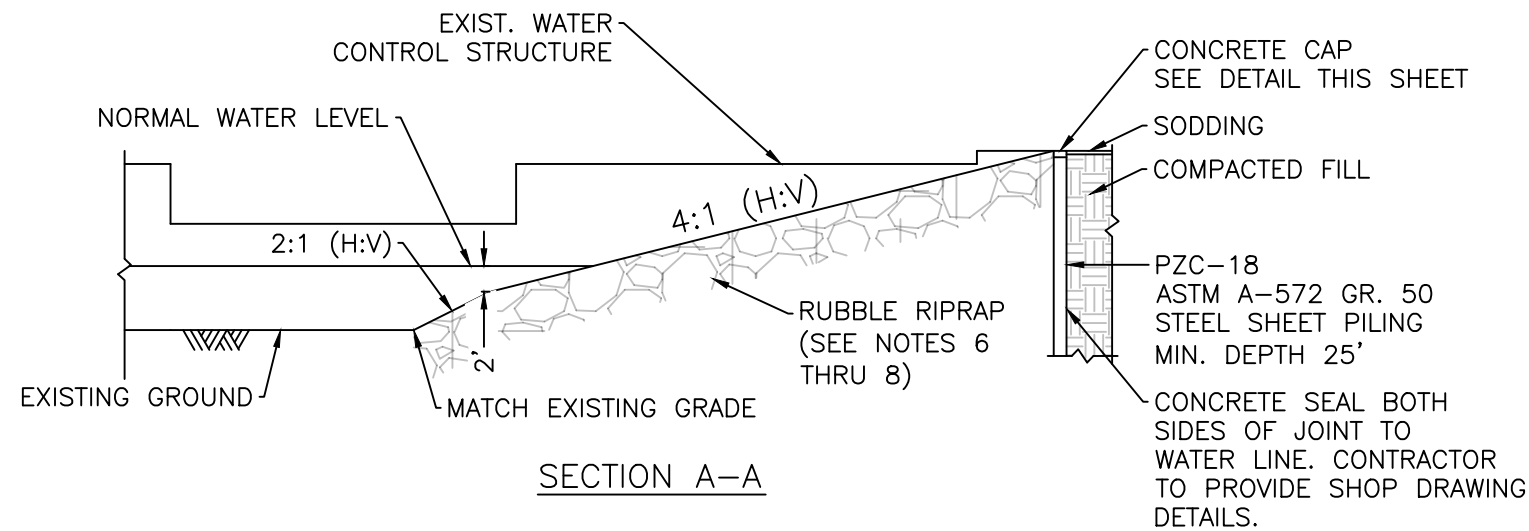

NOTICE: COMPONENTS OF TYPES ~ AND -- MAY BE SIMILAR OR IDENTICAL TO PROPRIETARY DESIGNS. ANY INFRINGEMENT ON THE PROPRIETARY RIGHTS SUBSTITUTIONS FOR TYPES ~ AND -- SHALL BE AS APPROVED BY THE ENGINEER.

FLOATING TURBIDITY BARRIERS

GENERAL NOTES:

1. FLOATING TURBIDITY BARRIERS ARE TO BE PAID FOR UNDER THE CONTRACT UNIT PRICE FOR FLOATING TURBIDITY BARRIER, LF.
2. STAKED TURBIDITY BARRIERS ARE TO BE PAID FOR UNDER THE CONTRACT UNIT PRICE FOR STAKED TURBIDITY BARRIER, LF.

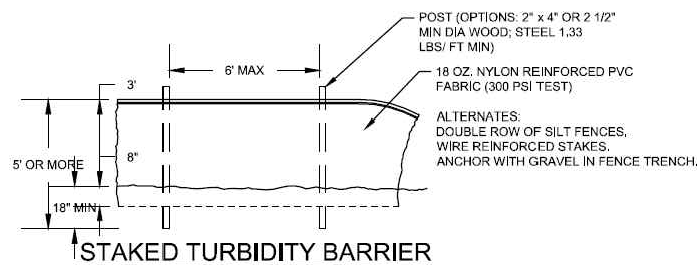

TURBIDITY BARRIER DETAILS
PER FDOT INDEX 103

NOTES:

1. THIS DRAWING IS INTENDED ONLY TO PROVIDE INFORMATION, AND IS NOT TO BE CONSIDERED A COMPLETE DESIGN FOR CONSTRUCTION. THE CONTRACTOR IS RESPONSIBLE FOR VERIFYING FIELD CONDITIONS AND PROVIDING TO THE CITY THE MEANS AND METHODS TO COMPLETE THE PRODUCT INCLUDING A DETAIL TO SHOW PROPOSED INTERFACE BETWEEN EXISTING STRUCTURE AND PROPOSED SHEET PILE.
2. THE QUANTITIES SHOWN ARE APPROXIMATE AND FOR REFERENCE ONLY.
3. THE CONTRACTOR IS TO RESTORE ANY DISTURBED AREAS TO AN EQUAL OR BETTER CONDITION THAN EXISTING.
4. THE CONTRACTOR IS TO FIELD VERIFY PROPERTY LINES SOUTH OF THE STRUCTURE TO ENSURE THAT ALL WORK IS ON CITY OWNED PROPERTY.
5. CONTRACTOR SHALL FURNISH ALL LABOR, EQUIPMENT AND MATERIALS NECESSARY TO CONSTRUCT THE BANK AND SHORE RIPRAP TO LINE AND GRADE AS SHOWN ON THE PLANS AND IN ACCORDANCE WITH THE PLANS AND FDOT STANDARD SPECIFICATIONS FOR ROAD AND BRIDGE CONSTRUCTION, FY 2023-24 EDITION, SECTION 530. THE RIPRAP IS TO HAVE A MINIMUM THICKNESS OF 2.5 FEET WITH A MINIMUM SPECIFIC GRAVITY OF 2.2 AND SHALL INCLUDE A FABRIC FILTER CAREFULLY AND PROPERLY PLACE UNDER IT. THE RIPRAP STONE SHALL MEET THE GRADATION AND THICKNESS REQUIREMENTS SET FORTH IN 530-2.1.3.1.
6. CONTRACTOR SHALL PLACE A 1 FOOT MINIMUM THICK LAYER OF BEDDING STONE UNDER THE RIPRAP PER SECTION 530-2.2.4.
7. RIPRAP AND BEDDING STONE SHALL BE PLACED OVER A GEO-TEXTILE FILTER FABRIC MEETING THE REQUIREMENTS OF FDOT SECTION 514 AND SECTION 985 D-2 CRITERIA AND PLACED IN ACCORDANCE WITH MANUFACTURER'S RECOMMENDATIONS.
8. THE D-2 GEOTEXTILE FILTER FABRIC, RIPRAP, AND BEDDING STONE SHALL BE INSTALLED UNDER DEWATERED (DRY) CONDITIONS FOR VERIFICATION OF PROPER INSTALLATION.
9. ALL BMP'S MUST BE INSPECTED EITHER WEEKLY OR AFTER EVERY 1/2" OF RAIN, WHICHEVER COMES FIRST.
10. THE TURBIDITY LIMIT IS 29 NTU ABOVE BACKGROUND LEVEL. IF TURBIDITY EXCEEDS THIS LIMIT, WORK MUST BE CEASED AND BMP'S MUST BE REPAIRED OR IMPROVED UNTIL THIS CRITERIA IS MET.

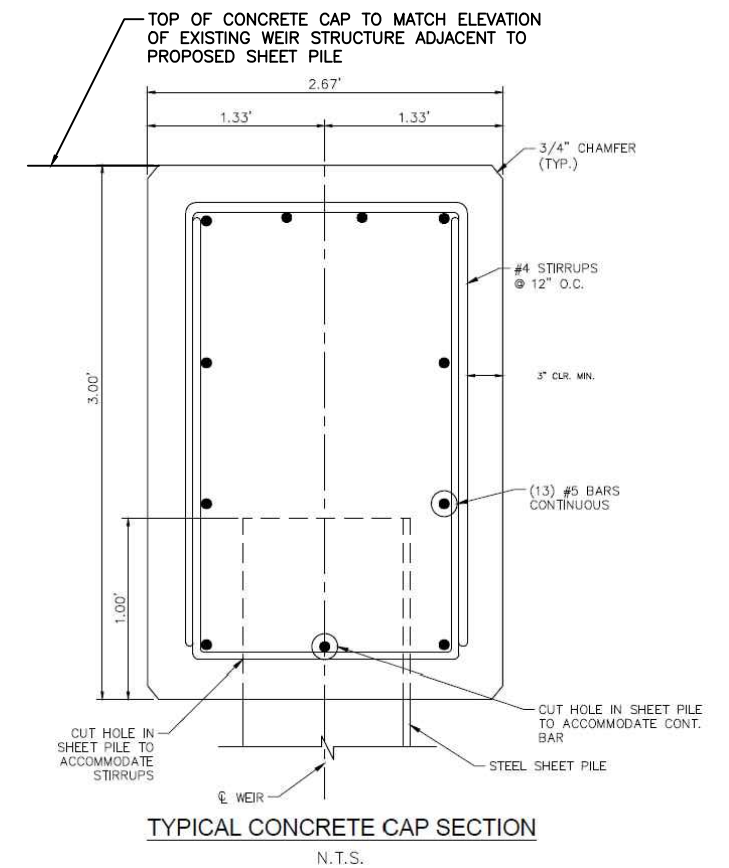

**FIXED WEIR 123 EROSION REPAIR
DETAILS AND NOTES**

City of North Port | Sarasota County, Florida
4970 City Hall Blvd., North Port, FL 34286

Drawn By: AMF

Date: 12/21/2022

Scale: 1"=15'

Sheet 4 of 4