

# City of North Port



## Request for Bid No. 2023-04

RENOVATION OF LIFT STATIONS 29, 45 AND 73

COMMUNITY DEVELOPMENT BLOCK GRANT



**NOTICE OF AVAILABILITY OF BID SPECIFICATIONS  
RFB NO. 2023-04  
RENOVATION OF LIFT STATIONS 29, 45 AND 73  
COMMUNITY DEVELOPMENT BLOCK GRANT**

The City of North Port is requesting sealed bids to secure the services of an experienced, professional, licensed, and qualified Contractor capable of providing construction services in accordance with the Renovation of Lift Stations 29, 45 and 73. The City intends to select one Contractor for renovation project associated with a Community Development Block Grant that the City has received. This is a federally funded project under Community Development Block Grant (CDBG) funding by the Department of Housing and Urban Development (HUD), Subrecipient Agreement Number B-21-UC-12-0014. All HUD federal rules and regulations pertaining to this project are applicable. Federal Davis-Bacon Wage Rates for work classifications are specified and must be complied with. Fringe benefits must be added to the prevailing hourly rates where applicable. The types of renovation work anticipated includes furnishing and installing new pumps, panels, piping, valves, fitting as shown on the construction plans and specified herein. The project includes bypass pumping and installation of fencing. Please see specification 011000, Summary of Work, for a detailed description of the work for each station.

**NON-MANDATORY PRE-BID MEETING: AUGUST 3, 2022, AT 2:00 PM  
4970 CITY HALL BOULEVARD, ROOM 244, NORTH PORT, FLORIDA 34286**

All potential Bidders are recommended to attend the non-mandatory pre-bid conference; and site visit will be conducted to answer questions regarding the bid requirements. The purpose of the Pre-Bid Meeting is to provide a briefing on the City's expectations and performance requirements for submission of Bid documents. Site visit will follow.

**BID OPENING: AUGUST 24, 2022, AT 2:00 PM  
4970 CITY HALL BOULEVARD, ROOM 337A, NORTH PORT, FLORIDA 34286**

**\*\*ALL BIDS ARE DATE AND TIME STAMPED IN THE FINANCE DEPARTMENT, SUITE 337 FIRST AND THEN ARE OPENED IN SUITE 337A\*\***

Information regarding this project may be viewed and downloaded from Demandstar's website at [www.demandstar.com](http://www.demandstar.com). The only place to obtain the addenda is on [www.demandstar.com](http://www.demandstar.com). Links to DemandStar are also available from the City website at [www.Cityofnorthport.com](http://www.Cityofnorthport.com). Bid specifications, attachments/exhibits are posted on the City FTP site at <https://www.cityofnorthport.com/fileshare> (**select the Purchasing Folder and scroll to Project RFB 2023-04**). If you have any questions, concerns, or problems accessing the bid package using the link, please contact Keith Raney, Contract Administrator II at 941.429.7103. Requests for additional information or clarification regarding the specifications must be sent via email to [purchasing@Cityofnorthport.com](mailto:purchasing@Cityofnorthport.com). No verbal requests will be honored. All questions and clarifications must be submitted via e-mail by **August 17, 2022 at 2:00 PM**

The City of North Port does not discriminate on the basis of race, color, national origin, sex, age, disability, family or religious status in administration of its programs, activities or services.

This is a federally assisted project and is subject to Federal Labor Standards which include, the Davis-Bacon Act (payment of prevailing wage rates) and the Copeland Act (anti-kickback of wages & submission of weekly certified payroll reports), as well as other provisions including 24 CFR 85.36 (bonding requirements), and Section 3 & M/WBE. Laborers and mechanics employed by primary contractors and sub-contractors performing construction work on this project shall be

**RFB No. 2023-04 RENOVATION OF LIFT STATIONS 29, 45 AND 73**

paid wages at rates not less than the prevailing rates as determined by the Secretary of Labor in accordance with the Davis-Bacon Act. The prime contractor is responsible for the enforcement of wage compliance and support documentation for the duration of the project and may be held liable for wage restitution. The applicable information regarding the laws and regulations stated above are included in the bid packet.

**PUBLISH DATES: August 22, 2022**

- Herald Tribune & Department of Labor
- [www.cityofnorthport.com](http://www.cityofnorthport.com) & [www.demandstar.com](http://www.demandstar.com)
- [Small Business Administration, Minority Business Development Agency of the Department of Commerce](#)

TABLE OF CONTENTS

<u>TITLE</u>	<u>PAGE NUMBERS</u>
NOTICE OF AVAILABILITY OF BID SPECIFICATIONS (LEGAL NOTICE)	2
TABLE CONTENTS	3
STATEMENT OF NON-SUBMITTAL	4
SECTION I: INSTRUCTION TO BIDDERS	5
SECTION II: GENERAL PROVISION	19
SECTION III: SPECIAL PROVISIONS	
SECTION IV: CDBG SPECIAL PROVISIONS	32
SECTION IV: CHECK LIST FOLLOWED BY ATTACHMENTS 1-18 TO BE COMPLETED AND RETURNED WITH BID	44
<i>SAMPLE CONTRACT: "THIS IS A 'SAMPLE CONTRACT' ISSUED FOR INFORMATIONAL PURPOSES ONLY AND AS SUCH IS SUBJECT TO CHANGE"</i>	72

EXHIBITS

ATTACHMENTS:

- 1A. Technical Specifications (268 Pages)
- 1B. Bid Form (1 page, also available in Excel format)
- 1C. Standard City of North Port Utilities Department Lift Station Detail Sheets (14 Pages)
- 1D. Key 21 Lift Station Information (1 Page)
- 1E. CDBG Wage Determination Rates-Heavy

STATEMENT OF NON-SUBMITTAL

If you **do not** intend to submit a bid on this service, please return this form (see information below) immediately.

We, the undersigned, have declined to submit a bid on the requested Request for Bid **2023-04 RENOVATION OF LIFT STATIONS 29, 45 AND 73**

\_\_\_\_\_ Insufficient time to respond to the Request for Bid.

\_\_\_\_\_ We do not offer this product/service.

\_\_\_\_\_ Our schedule would not permit us to perform.

\_\_\_\_\_ Unable to meet bond/insurance requirements.

\_\_\_\_\_ Specifications are unclear (explain below).

\_\_\_\_\_ OTHER (please specify below).

REMARKS: \_\_\_\_\_  
\_\_\_\_\_

COMPANY NAME: \_\_\_\_\_

ADDRESS: \_\_\_\_\_

CITY: \_\_\_\_\_ STATE: \_\_\_\_\_ ZIP CODE: \_\_\_\_\_

TELEPHONE: \_\_\_\_\_ FAX: \_\_\_\_\_

E-MAIL ADDRESS: \_\_\_\_\_

SIGNATURE: \_\_\_\_\_

DATE: \_\_\_\_\_

Note: "Statement of No Bid" may be faxed or e-mailed to the Purchasing Division at [purchasing@Cityofnorthport.com](mailto:purchasing@Cityofnorthport.com).

## SECTION I. INSTRUCTIONS TO BIDDERS

THESE CONDITIONS ARE STANDARD FOR ALL BIDS FOR COMMODITIES/SERVICES ISSUED BY THE CITY OF NORTH PORT. THE CITY OF NORTH PORT MAY DELETE, SUPERSEDE OR MODIFY ANY OF THESE GENERAL CONDITIONS FOR A PARTICULAR CONTRACT BY INDICATING SUCH CHANGE IN SPECIAL CONDITIONS TO BIDDERS OR IN THE BID SHEETS. ANY AND ALL SPECIAL CONDITIONS THAT MAY VARY FROM THE GENERAL CONDITIONS SHALL HAVE PRECEDENCE. BIDDER AGREES THAT THE PROVISIONS INCLUDED WITH THIS REQUEST FOR BID SHALL PREVAIL OVER ANY CONFLICTING PROVISIONS WITHIN ANY STANDARD FORM CONTRACT OF THE BIDDER REGARDLESS OF ANY LANGUAGE IN BIDDER'S CONTRACT TO THE CONTRARY.

**DEFINITIONS:** Terms used in these Instructions to Bidders are defined and have the meanings assigned to them.

- **Addenda:** a written change to a solicitation
- **Bid:** any offer submitted in response to this request for Bid.
- **Bidder:** One that submits a bid in response to this Request for Bid.
- **Bid Documents:** Includes the General Terms and Conditions: Special Conditions: Technical Specifications, the Bid Form: Non-Collusive Affidavit: Public Entity Crime Form: Certificate(s) of Insurance, if required: Payment and Performance Bonds, if required: Corporate Resolution: Bid Bond, if required: Local Business Affidavit, Scrutinized Company Affidavit and Certification and all Addendums issued prior to receipt of bids.
- **City:** Shall refer to City of North Port, a municipal corporation of the State of Florida.
- **Contract:** The agreement to perform the services set forth in this solicitation. The Contract will be comprised of the Bid documents signed by both parties including any addenda and other attachments specifically incorporated.
- **Responsible:** Refers to a Bidder that has the capacity and capability to perform the work required under a Request for Bid and is otherwise eligible for award.
- **Responsive:** Refers to a bid that contains no exceptions or deviations from the terms, conditions, and specifications set forth in the Request for Bid.
- **Request for Bid (RFB):** Shall mean this solicitation document, including any and all addenda. A RFB contains well-defined terms, conditions, and specifications, and is awarded to the lowest priced responsive and responsible Bidder.
- **Solicitation:** The written document requesting either bids or proposals from the marketplace.
- **Successful Bidder(s):** The lowest responsive, responsible Bidder(s) to whom City (on basis of City's evaluation) makes an award.
- **Vendor or Contractor:** A general reference to any entity responding to this solicitation or performing under any resulting Contract.

The City has established for purposes of this Request for Bid (RFB) that the words "shall," "must," or "will" are equivalent and indicate a mandatory requirement or condition, the material deviation from which shall not be waived by the City. A deviation is material if, in the City's sole discretion, the deficient response does not substantially satisfy this RFB's mandatory requirements. The words "should" or "may" are equivalent in this RFB and indicate very desirable conditions, or requirements that are permissive in nature.

### 1. INSTRUCTIONS TO BIDDERS

**A. QUALIFICATIONS OF BIDDER:** It is intent to the City to award this Contract to the lowest responsible Bidder, qualified by experience and solvency, with proven reliability and the ability to provide the services or items required under this Contract within a reasonable time frame acceptable to the City. Bidder may be required to supply information in writing at the request and discretion of the City prior to award of bids, in order to verify above requirements.

**B. EXAMINATION OF BID DOCUMENTS:** Prior to submission of a bid form, Bidders shall carefully examine the General Terms and Conditions, Special Conditions, Technical Specifications, and all other related bid documents, including all modifications thereof, incorporated in the bid package, plus fully informing themselves as to all existing conditions and limitations that effect the work to be performed under this Contract.

## RFB No. 2023-04 RENOVATION OF LIFT STATIONS 29, 45 AND 73

Discrepancies, omissions, or questions about the intent of the documents should be submitted to the Purchasing Division in written form as a request for interpretation no later than five business (5) days prior to bid opening (or shall be verbally addressed at the pre-bid conference, if applicable).

It shall be the responsibility of the Bidder, prior to submitting their response, to either visit [www.demandstar.com](http://www.demandstar.com) to view the solicitation and download all issued addenda or contact Purchasing to determine if addenda were issued.

**Examination of site:** Prior to submitting a bid form, each Bidder may examine the site and all conditions thereon. All bid forms shall be presumed to include all such existing conditions as may affect any work to be done on this project. Failure to familiarize himself with such conditions will in no way relieve the successful Bidder from the necessity of furnishing any materials or performing any work that may be required to complete the work in accordance with the Specifications.

**C. CLARIFICATION AND ADDITIONAL INFORMATION:** Discrepancies, omissions, or questions about the intent of the documents will be submitted to the City of North Port Purchasing Manager, or his/her designee in written form as a request for interpretation no later than five (5) business days prior to the bid opening (or may be verbally addressed at the pre-bid meeting, if applicable).

Interpretations made will be in the form of an addendum to the documents, which will be forwarded to all Bidders. Receipt by each Bidder must be acknowledged on the bid form, indicating the addendum number and date of issue, therein becoming part of the Contract. No oral explanations shall be binding. The City will attempt to notify all prospective Bidders of addenda issued to the bid documents: however, it shall be the responsibility of the Bidder, prior to submitting their bid, to contact the Purchasing Manager, or his/her designee, to determine if addenda were issued, acknowledging and incorporating it into their bid.

**D. MODIFICATION OR WITHDRAWAL OF BIDS:** Bid modifications will be accepted from a Bidder only if received in writing, properly signed by an officer of the Bidder, and received prior to the opening of bids. Bid modifications must be identified as such and will be opened with the Bidder's bid form.

Bids may be withdrawn by request of the Bidder prior to the time fixed for opening. Error or negligence on the part of the Bidder in preparing the bid confers no right for the withdrawal of the bid after it has been opened.

**E. NO BID:** A respondent who is on the bid notification list and decides not to submit a response is requested to complete the Statement of Non-Submittal Form and return it to the City.

**F. CONFLICTS WITHIN SOLICITATION:** Where there appears to be a conflict between the General Terms and Conditions, Special Conditions, the Technical Specifications, the Bid Form, or any addendum issued, the order of precedence shall be: the last addendum issued, the Bid Form, the Technical Specifications, the Special Conditions, and then the General Terms and Conditions. It is incumbent upon the vendor to identify such conflicts to the designated purchasing representative prior to the bid or proposal response date.

**G. PROMPT PAYMENT:** It is the policy of the City that payment for all purchases by the City shall be made in a timely manner and that interest payments will be made on late payments in accordance with Part VII, Chapter 218, Florida Statutes, known as the Local Government Prompt Payment Act. The Bidder may offer cash discounts for prompt payments: however, such discounts will not be considered in determining the lowest price during bid evaluation.

## 2. PREPARATION AND SUBMISSION OF BID FORM

***Bid Form:*** Bids shall be made on forms supplied by the City, or as otherwise specified. Each bid must state the name of the Bidder, the Bidder's full business address and state the type of business entity, followed by the original signature and designation of the officer or other person authorized to bind the corporation. Any erasures or other corrections in the bid form must be explained or noted over the signature of the Bidder. Bid forms containing any conditions, omissions, unexplained erasures, alterations, or irregularities of any kind may be rejected by the City.

## RFB No. 2023-04 RENOVATION OF LIFT STATIONS 29, 45 AND 73

**Bid Bond:** Each bid must be accompanied by a Bidder's bond or Cashier's check with their bid in the amount of NOT LESS THAN 5% of their total amount of the bid. This security shall ensure that the Bidder does not revoke the bid after bid opening or fails to execute any necessary additional documents. Cashier's checks will be returned to all Bidders after award of bid. If using a bid bond use the City of North Port bid bond form.

**Bid Documents:** Bid documents and forms shall be submitted sealed to the City of North Port, Purchasing, 4970 City Hall Boulevard, Suite 337, North Port, Florida 34286. The envelope/package shall be clearly marked with the Bid Number, Name and Business Address of the Bidder. All interested firms are required to submit one (1) original and one (1) copy of their completed bid offer.

Submission of a response constitutes a binding offer and shall be subject to all terms and conditions specified in the solicitation.

For your bid to be acceptable, **all blank spaces** must be completely annotated where and when requested. All bids must contain a manual signature of the authorized representative of the Bidder in the space provided on the Bid Certification Form.

Responsibility for getting this bid to the City on or before the specified date and time is solely and strictly the responsibility of the Bidder. The City will not be responsible for any delay, for any reason whatsoever. Bids must be received and stamped with the date and time on the outside of the envelope and must be in the City Purchasing Office by the date and time specified for opening.

Bids postmarked prior to said date and time but not received shall not be considered and will be returned to Bidder unopened.

**Bid Guarantee:** The bid form shall be signed where indicated constituting an agreement that the Bidder will not withdraw his/her bid for a period of ninety (90) days after the opening of the bids.

**Source of Supply and Subcontractors:** Bidders are to complete the attached Source of Supply and subcontractors form. This form must be completed and included with the bid form. If Bidder does not have a source of supply or subcontractor, insert "to be determined". When source or subcontractor is determined, selection will be subject to City approval.

**Bid Opening:** All bids received by the date and time so specified shall be opened and **the name of each Bidder and total bid price of each Bidder** read aloud within the designated room at City Hall, at the bid opening. The opening and reading shall be in the presence of the City Clerk and the Purchasing Manager or their designees. Bidders and the general public are not required to be present but are invited to attend.

**Late Bids:** Bids received after the date and time of bid opening will not be considered and will not be opened. It will be the Bidder's responsibility to make arrangements for the return of the bid package at their expense.

**3. CITY RIGHTS:** The City of North Port reserves the right to accept or reject any and/or all bids in whole or in part, to waive irregularities and technicalities, and to request resubmission with or without cause and/or to accept the bid that, in its judgment, will be in the best interest of the City. Also, the City reserves the right to accept all or any part of the bid and to increase or decrease quantities to meet additional or reduced requirement of the City. In the event the City receives only one response: the bid may be either accepted or rejected by the City depending on available competition and the timely needs of the City.

**4. AWARD OF BID:** The award shall be let to the lowest responsive, responsible Bidder who fulfills all criteria and specifications with consideration to favorable references and local preference and whose evaluation by the City indicates that the award will be in the best interest of the City.

**5. ERRORS:** For the purpose of the initial evaluation of bids, the following will be utilized in resolving arithmetic



**RFB No. 2023-04 RENOVATION OF LIFT STATIONS 29, 45 AND 73**

discrepancies found on the face of the bidding schedule as submitted by Bidders:  
Obviously misplaced decimal points will be corrected.

In case of discrepancy between unit price and extended price, the unit price will govern. Apparent errors in extension will be corrected.

Apparent errors in addition of lump sum and extended prices will be corrected. For the purpose of bid evaluation, the City will proceed on the assumption that the Bidder intends his/her bid be evaluated on the basis of the unit prices, extensions, and totals arrived at by resolution of arithmetic discrepancies as provided above and the bid will be so reflected on the tabulation of bids.

**6. BID TABULATIONS:** Pursuant to Florida Statute §119.071(1)(b), all bid tabulations shall be posted in the City Hall, 4970 City Hall Boulevard, North Port, Florida and on DemandStar's website at [www.demandstar.com](http://www.demandstar.com) within thirty (30) days after bid opening or at such time as the agency provides notice of a decision or intended decision, whichever is earlier.

**7. WARRANTY:** All warranties express and implied, shall be made available to the City for goods and services covered by this solicitation. All goods furnished shall be fully guaranteed by the vendor against factory and workmanship defects. At no expense to the City, the vendor shall correct any and all apparent and latent defects that may occur within the manufacturer's standard warranty period. The special conditions of the solicitation may supersede the manufacturer's standard warranty.

**8. DESCRIPTIVE INFORMATION:** Unless otherwise specifically provided in the Technical specifications, all equipment, materials and articles incorporated in the work covered by this Contract are to be new and of the most suitable grade for the purpose intended. Unless otherwise specifically provided in the Technical specifications, reference to any equipment, material, article or patented process, by trade name, make or catalog number, shall be regarded as establishing a standard of quality and shall not be construed as limiting competition. If the Bidder wishes to make a substitution to the specifications, the Bidder shall furnish the City the name of the manufacturer, the model number and other identifying data and information necessary to aid in the City in evaluating the substitution. Such substitution shall be subject to City approval. Substitutions shall be approved only if determined by the City to be equivalent to the specifications. A bid containing substitution is subject to disqualification if the City does not approve the substitution.

**9. TAXES/FREIGHT:** The bid shall include any freight, handling, delivery, surcharges or other incidental charges. Unless otherwise specified in the solicitation, prices quoted shall be F.O.B. Destination. The City is exempt from the payment of Federal and State taxes, including sales tax. The bid offer shall not include sales tax to be collected from the City. The City's sales tax exemption is not available to vendor for items vendor purchases, regardless of whether these items will be transferred to the City.

In the event the project is declared a sales tax recovery project by the City, the following procedure shall apply:

- (a) The City representative shall make a recommendation to the Division of Procurement Services regarding the materials to be purchased:
- (b) When those materials are purchased by the City, all purchase orders shall be issued directly from Purchasing:
- (c) The City shall take title to those materials directly from the manufacturer/supplier and shall bear the risk of loss or damage to the materials which are delivered directly from the manufacturer/supplier:
- (d) The City shall be invoiced directly for the materials from the manufacturer/supplier and shall pay the invoices directly to the manufacturer/supplier, presenting its sales tax exemption certificate at the time of payment.

The cost of any materials purchased through the sales tax recovery program shall be deducted from the Contract amount and the vendor shall no longer be responsible for providing those materials. A written change order shall be executed.

**10. CONTINUATION OF WORK:** Any work that commences prior to and will extend beyond the expiration date of the

## RFB No. 2023-04 RENOVATION OF LIFT STATIONS 29, 45 AND 73

current Contract period shall, unless terminated by mutual written agreement between the City and the vendor, continue until completion without change to the then current prices, terms and conditions.

### 11. TERMINATION OF CONTRACT:

Funding in Subsequent Fiscal Years: It is expressly understood by the City and the vendor that funding for any successive fiscal years of the Contract is contingent upon appropriation of monies by the City Commissioners. In the event that funds are not available or appropriated, the City reserves the right to terminate the Contract. The City will be responsible for payment of any outstanding invoices and work completed by the vendor prior to such termination.

Termination With or Without Cause: The City shall have the right to unilaterally cancel, terminate or suspend this Contract, in whole or in part, by providing the Contractor thirty (30) days written notice by certified mail.

The City reserves the right to terminate this Contract, in part or in whole, in the event the vendor fails to perform in accordance with the terms and conditions stated herein. The vendor will be notified by letter of the City's intent to terminate. In the event of termination for default, the City may procure the required goods and/or services from any source and use any method deemed in its best interest. All re-procurement cost shall be borne by the vendor.

Termination by Vendor: Vendor shall have the right to terminate services only in the event of the City failing to pay Vendor's properly documented and submitted invoice within ninety (90) calendar days of the approval by the City's Administrative Agent, or if the project is suspended by the City for a period greater than ninety (90) calendar days.

**12. PROPRIETARY OR CONFIDENTIAL INFORMATION:** Bidders are hereby notified that all information submitted as part of, or in support of bid submittals will be available for public inspection after opening of bids in compliance with Chapter 119 of the Florida Statutes, the Public Record Act. The Bidder should not submit any information in response to this solicitation which the Bidder considers proprietary or confidential. The submission of any information to the City in connection with this solicitation shall be deemed conclusively to be a waiver of any protection from release of the submitted information unless such information is exempt from disclosure under the Public Records Act, and such information is marked as exempt. Failure to mark a trade secret as exempt waives the exemption.

**13. RULES, REGULATIONS AND LICENSES:** The vendor shall comply with all federal, state, and local laws and regulations applicable to provision of the goods and/or services specified in this solicitation.

It shall be the responsibility of the Contractor to assure compliance with OSHA, EPA and/or other local, federal, or State of Florida rules, regulations or other requirements, as each may apply.

When applicable and as required by law, the Bidder will provide a material safety data sheet with each delivery of a toxic substance.

The vendor shall maintain books, records, documents, and other evidence directly pertaining to or connected with the services under this Agreement which shall be available and accessible at the Vendor's offices for the purpose of inspection, audit, and copying during normal business hours by the City, or any of its authorized representatives. Such records shall be retained for a minimum of five (5) years after completion of the services.

**14. CODE OF ETHICS:** With respect to this bid, if any Bidder violates or is a party to a violation of the Florida Statutes, Chapter 112, Part III, Code of Ethics for Public Officers and Employees, such Bidder may be disqualified from furnishing the goods or services for which the bid is submitted and shall be further disqualified from submitting any future bids for goods or services for the City.

**15. COLLUSION:** By offering a submission to this RFB, the Bidder certifies that the Bidder has not divulged to, discussed or compared his/her bid with other Bidders and has not colluded with any other Bidder or parties to this bid whatsoever. Also, Bidder certifies, and in the case of a joint bid each party thereto certifies as to his/her own organization, that in connection with this bid: any prices and/or cost data submitted have been arrived at independently, without

**RFB No. 2023-04 RENOVATION OF LIFT STATIONS 29, 45 AND 73**

consultation, communication, or agreement, for the purpose of restricting competition, as to any matter relating to such prices and or cost data, with any other Bidder or with any competitor: any prices and/or data quoted for this bid have not been knowingly disclosed by the Bidder and will not knowingly be closed by the Bidder prior to the scheduled opening directly or indirectly to any other Bidder or to any competitor: no attempt has been made or will be made by the Bidder to induce any other person or firm to person or persons interested in this bid, principal or principals is/are named therein and that no person other than therein mentioned has any interest in this bid or in the Contract to be entered into: and no person or agency has been employed or retained to solicit or secure this Contract upon an agreement or understanding for a commission, percentage, brokerage, or contingent fee excepting bona fide employees of the Bidder.

**16. PUBLIC ENTITY CRIMES:** In accordance with Florida Statutes Sec. 287.133(2)(a), "A person or affiliate who has been placed on the convicted vendor list following a conviction for a public entity crime may not submit a bid on a Contract to provide any goods/services to public entity, may not submit a bid on a Contract with a public entity for construction or repair of public building or public work, may not submit bids on leases of real property to a public entity, may not be awarded or perform work as a Contractor, supplier, subcontractor, or consultant under a Contract with any public entity, and may not transact business with any public entity in excess of the threshold amount provided in Sections 287.017, for Category Two, for a period of 36 months from the date of being placed on the convicted vendor list." By submitting a bid, vendor certifies that vendor is not currently prohibited from transacting business with the City due to the above statute. The vendor shall comply with the terms of this statute both before and during the term of this Contract.

**17. DRUG FREE WORKPLACE PREFERENCE:** The City has adopted a policy in observation of the Drug Free Workplace Act of 1988. Therefore, it is unlawful to manufacture, distribute, dispense, possess, or use any controlled substance in the City workplace.

The City requests that the attached Drug Free Workplace Affidavit accompany the bid response. This form has been adopted by the City in accordance with the Drug Free Workplace Act. The City will not disqualify any Bidder who does not sign the affidavit. The Drug Free Workplace Affidavit is primarily used as a tie breaker when two or more separate entities have submitted bids at the same price, terms and conditions, with preference given to the Bidder who has signed the affidavit.

**18. EQUAL EMPLOYMENT OPPORTUNITY:** The City of North Port, Florida, in accordance with the provisions of Title VII of the Civil Rights Act of 1964 (78 Stat. 252) and the Regulations of the Department of Commerce (15 CFR, Part 8) issued pursuant to such Act, hereby notifies all Bidders that it will ensure that in any Contract entered into pursuant to this advertisement, minority business enterprises will be afforded full opportunity to submit replies in response to this advertisement and will not be discriminated against on the ground of race, color or national origin in consideration for an award.

**19. NON-DISCRIMINATION:** The City of North Port does not discriminate on the basis of race, color, national origin, sex, age, disability, family or religious status in administration of its programs, activities or services. Pursuant to F.S §287.134(2)(a), an entity or affiliate who has been placed on the discriminatory vendor list may not submit a bid, proposal, or reply on a Contract to provide any goods or services to a public entity: may not submit a bid, proposal, or reply on a Contract with a public entity for the construction or repair of a public building or public work: may not submit bids, proposals, or replies on leases of real property to a public entity: may not be awarded or perform work as a Contractor, supplier, subcontractor, or consultant under a Contract with any public entity: and may not transact business with any public entity.

**20. DECLARATION OF EXEMPTION FROM PUBLIC RECORD:** Pursuant to Florida Statute §119.07(1)(b)(2), all bid documents are exempt from public record until such time as the City provides notice of an intended decision or until 30 days after opening the bids, whichever is earlier.

In accordance with Florida Statutes 119.0701, Contractor shall comply with all public records laws, and shall specifically:

20.1. Keep and maintain public records required by the City to perform the service.

a. The timeframes and classifications for records retention requirements must be in accordance with the General Records Schedule GS1-SL for State and Local Government Agencies.  
(See <http://dos.state.fl.us/library-archives/records-management/general-records-schedules/> ).

b. "Public records" means and includes those items specified in Florida Statutes 119.011(12), as amended from time to time, and currently defined as: All documents, papers, letters, maps, books, tapes, photographs, films, sound recordings, data processing software, or other material, regardless of the physical form, characteristics, or means of transmission, made or received pursuant to law or ordinance or in connection with the transaction of official business with the City. Contractor's records under this Contract include but are not limited to, supplier/subcontractor invoices and Contracts, project documents, meeting notes, e-mails and all other documentation generated during this Contract.

20.2. Upon request from the City's custodian of public records, provide the City, at no cost, with a copy of the requested records or allow the records to be inspected or copied within a reasonable time at a cost that does not exceed the cost provided for by law. All records kept electronically must be provided to the City, upon request from the City's custodian of public records, in a format that is compatible with the information technology systems of the City.

20.3. Ensure that project records that are exempt or confidential and exempt from public records disclosure requirements are not disclosed except as authorized by law for the duration of the Contract term and, if the Contractor does not transfer the records to City following completion of the Contract, for the time period specified in General Records Schedule GS1-SL for State and Local Government Agencies.

20.4. Upon completion of the Contract, transfer, at no cost, to the City all public records in Contractor's possession or keep and maintain public records required by the City to perform the service. If the Contractor transfers all public records to the City upon completion of the Contract, the Contractor shall destroy any duplicate public records that are exempt or confidential and exempt from public records disclosure requirements. If the Contractor keeps and maintains public records upon the completion of the Contract, the Contractor shall meet all applicable requirements for retaining public records.

**20.5. IF THE CONTRACTOR HAS QUESTIONS REGARDING THE APPLICATION OF CHAPTER 119, FLORIDA STATUTES, TO THE CONTRACTOR'S DUTY TO PROVIDE PUBLIC RECORDS RELATING TO THIS CONTRACT, CONTACT THE CUSTODIAN OF PUBLIC RECORDS AT CUSTODIAN OF PUBLIC RECORDS, 4970 CITY HALL BOULEVARD, NORTH PORT, FLORIDA 34286, 941.429.7063 OR HOTLINE 941.429.7270: E-MAIL: [publicrecordsrequest@Cityofnorthport.com](mailto:publicrecordsrequest@Cityofnorthport.com).**

20.6. Failure of the Contractor to comply with these requirements shall be a material breach of this Contract. Further, Contractor may be subject to penalties under Florida Statutes 119.10.

**21. FORCE MAJEURE:** Should performance of any obligation created under this Agreement become illegal or impossible by reason of:

- a. A strike or work stoppage, unless caused by a negligent act or omission of either Party;
- b. An act of God, tornado, hurricane, flood, sinkhole, fire, explosion, landslide, earthquake, epidemic, pandemic, quarantine, pestilence, or extremely abnormal and excessively inclement weather;
- c. An act of a public enemy, act of war, terrorism, effect of nuclear radiation, blockage, insurrection, riot, civil disturbance, state of martial law, or national or international calamity;
- d. A declared emergency of the federal, state, or local government; or
- e. Any other like event that is beyond the reasonable control of the non-performing party;

**RFB No. 2023-04 RENOVATION OF LIFT STATIONS 29, 45 AND 73**

then the performance of any such obligation is suspended during the period of, and only to the extent of, such prevention or hindrance, provided that:

- f. The non-performing party provides written notice within five (5) days of the event of *force majeure*, describing the event in sufficient detail, including but not limited to: the nature of the occurrence, a good faith estimate of the duration of the delay, proof of how the event has precluded the non-performing party from performing, and the means and methods for correcting the delay; and continues to furnish timely reports of all actions required for it to commence or resume performance of its obligations under this Agreement;
- g. The excuse of performance is no greater in scope or duration than required by the event of *force majeure*;
- h. No obligations of either party that arose before the *force majeure* are excused as a result of the event of *force majeure*; and
- i. The non-performing party uses all reasonable diligence to remedy its inability to perform.

Economic hardship of a party does not constitute an event of *force majeure*. A party will not be excused from performance due to forces that it could have reasonably prevented, removed, or remediated prior to, during, or immediately after their occurrence.

The non-performing party's affected obligations under this Agreement will be temporarily suspended during, but not longer than, the continuance of the event of *force majeure* and a reasonable time thereafter as may be required to commence or resume performance of its obligations. Notwithstanding the above, performance shall not be excused under this Section for a period exceeding two (2) months, provided that in extenuating circumstances, the City may excuse performance for a longer term.

**22. GOVERNING LAWS:** The interpretation, effect, and validity of any Contract resulting from this RFB shall be governed by the laws and regulations of the State of Florida. Exclusive venue of any court action shall be in Sarasota County, Florida.

**23. SUBCONTRACTING:** Unless otherwise specified in this solicitation, the vendor shall not subcontract any portion of the work without the prior written consent of the City. The ability to subcontract may be further limited by the Special Conditions. Subcontracting without the prior consent of the City may result in termination of the Contract for default.

**24. MODIFICATION OF CONTRACT:** Any Contract resulting from this solicitation may be modified by mutual consent of duly authorized parties, in writing through the issuance of a modification to the Contract and/or change order as appropriate. This presumes the modification itself is in compliance with all applicable City procedures.

**25. SUCCESSORS AND ASSIGNS:** The vendor shall not assign any interest in any Contract resulting from this solicitation and shall not transfer any interest in same (whether by assignment or novation) without prior written consent of the City, except that claims for the money due or to become due to the vendor from the City under any Contract may be assigned to a financial institution or to a trustee in bankruptcy without such approval from the City. Notice of such transfer or assignment due to bankruptcy shall be promptly given to the City.

**26. CONTRACTING WITH CITY EMPLOYEES OR BOARD MEMBERS:** Any City employee, Board member or member of his or her immediate family seeking to Contract with the City shall seek a conflict of interest opinion from the purchasing manager or their designated representative prior to submittal of a response or application of any type to Contract with the City. The affected employee or Board member shall disclose his or her assigned function within the City and interest or the interest of his or her immediate family in the proposed Contract and the nature of the intended Contract.

Florida Statute §112.313(12) Standards of Conduct for Public Officers, Employees of Agencies, and Local Government Attorneys controls Contracting with City employees or board members, and provides as follows:

(12) EXEMPTION. --The requirements of subsections (3) and (7) as they pertain to persons serving on advisory boards may be waived in a particular instance by the body which appointed the person to the advisory board, upon a full disclosure of the transaction or relationship to the appointing body prior to the waiver and an affirmative vote in favor of waiver by two-thirds vote of that body. In instances in which appointment to the advisory board is made by an

**RFB No. 2023-04 RENOVATION OF LIFT STATIONS 29, 45 AND 73**

individual, waiver may be effected, after public hearing, by a determination by the appointing person and full disclosure of the transaction or relationship by the appointee to the appointing person. In addition, no person shall be held in violation of subsection (3) or subsection (7) if:

- (b) The business is awarded under a system of sealed, competitive bidding to the lowest or best Bidder and:
1. The official or the official's spouse or child has in no way participated in the determination of the bid specifications or the determination of the lowest or best Bidder;
  2. The official or the official's spouse or child has in no way used or attempted to use the official's influence to persuade the agency or any personnel thereof to enter such a Contract other than by the mere submission of the bid; and
  3. The official, prior to or at the time of the submission of the bid, has filed a statement with the Commission on Ethics, if the official is a state officer or employee, or with the supervisor of elections of the county in which the agency has its principal office, if the official is an officer or employee of a political subdivision, disclosing the official's interest, or the interest of the official's spouse or child, and the nature of the intended business.

**27. TRUTH-IN-NEGOTIATIONS CERTIFICATE:** If applicable, execution and signature by the vendor of the Bid Form shall act as the execution of a truth-in-negotiation certificate certifying that the wage rates and costs used to determine the compensation provided for in this Contract are accurate, complete, and current as of the date of the Contract.

For professional service Contracts, the original Contract price and any additions thereto will be adjusted to exclude any significant sums by which the City determines the Contract price was increased due to inaccurate, incomplete, or noncurrent wage rates and other factual unit costs. The City shall exercise its rights under this "Certificate" within one (1) year following payment.

**28. GRANT FUNDING:** In the event any part of the Contract is to be funded by federal, state, or other local agency monies, the vendor hereby agrees to comply with all requirements of the funding entity applicable to the use of the monies, including full application of requirements involving the use of minority firms, women's business enterprises, and labor surplus area firms. Vendors are advised that payments under the Contract may be withheld pending completion and submission of all required forms and documents required of the vendor pursuant to the grant funding requirements. A copy of the requirements shall be supplied to the vendor by the City upon request.

**29. PERFORMANCE/PAYMENT BOND:** The successful Bidder shall provide the required performance and payment bond or other acceptable security to the City within **ten (10) business days of being awarded the bid. Failure by the successful Bidder to provide the bond within ten (10) business days shall be considered a default under Sec. 2-404 of the City of North Port Administrative Code.** Such default shall only be curable at the option of the City. In addition, the Contractor shall be responsible and bear all costs associated to record Performance and Payment Bond with Sarasota County Clerk's Office. Receipt of said recording and certified copy of the bond shall be furnished to the Purchasing Department at the time of the pre-construction meeting. Such default shall only be curable at the option of the City.

In addition, the Contractor shall be responsible and bear all costs associated to record Performance and Payment Bond with Sarasota County Clerk's Office. Receipt of said recording and certified copy of the bond shall be furnished to the Purchasing Department at the time of the pre-construction meeting. Such default shall only be curable at the option of the City.

Upon such default, the City may immediately award the bid to the next lowest responsive and responsible Bidder and recover from the original successful Bidder the difference in cost between the original winning bid and the next lowest responsive and responsible Bidder.

**PERFORMANCE/PAYMENT BOND REQUIREMENTS:** The Contractor shall provide a Performance Bond and a Payment Bond, in the form prescribed in Section 3, Contract Documents, each in the amount of 100% of the Contract amount,

**RFB No. 2023-04 RENOVATION OF LIFT STATIONS 29, 45 AND 73**

the costs of which are to be paid by the Contractor. The bonds will be acceptable to the City only if the following minimum conditions are met:

- a. is licensed to do business in the State of Florida:
- b. holds a certificate of authority authorizing it to write surety bonds in this state:
- c. has twice the minimum surplus and capital required by the Florida Insurance Code at the time the invitation to bid is issued:
- d. is otherwise in compliance with the provisions of the Florida Insurance Code: and holds a currently valid certificate of authority issued by the United States Department of Treasury under 31 U.S.C. §§ 9304-9308.
- e. The Surety Company must have a current rating of at least Excellent (A or A-) as reported in the most current Best Key Rating Guide, published by A.M. Best Company, Inc., of 75 Fulton Street, New York, New York 10038, with an underwriting limitation **of at least two times the dollar amount of the Contract.**

If the Surety Company for any Bond furnished by the Contractor files for bankruptcy, has a receiver appointed, is declared bankrupt, becomes insolvent, has an assignment made for the benefit of creditors, has its right to do business terminated in the State of Florida, or ceases to meet the requirements imposed by the Contract Documents, the Contractor shall, within five (5) calendar days thereafter, substitute another Bond and Surety Company, both of which shall be subject to the City's approval.

By execution of these bonds, the Surety Company acknowledges that it has read the surety qualifications and surety obligations imposed by the Contract documents and hereby satisfies those conditions.

**30. STATE REGISTRATION REQUIREMENTS:** Any Bidder required by Florida law to register to do business in this state shall either be registered or have applied for registration with the Florida Department of State in accordance with the provisions of Chapter 607, 608, 617, or 621, Florida Statutes, unless they are exempt. A copy of the registration/application may be required prior to award of a Contract. Any partnership submitting a bid in response to this RFB shall have complied with the applicable provisions of Chapter 620, Florida Statutes.

**31. NOTICE TO PROCEED/DELIVERY:** After award of bid, a Notice to Proceed shall be issued bearing the terms of delivery. Upon receipt of Notice to Proceed, successful Bidder shall acknowledge receipt of same by either fax or mail and shall commence prosecution of the order so that the agreed upon delivery date will be satisfied.

**32. PERFORMANCE EVALUATION:** At the end of the Contract, the receiving department may evaluate the successful Bidder's performance. This evaluation will become public record.

**33. PURCHASING AGREEMENTS WITH OTHER GOVERNMENTAL AGENCIES:** All Bidders submitting a response to this RFB agree that such response also constitutes a bid in accordance with the terms of the RFB to all political subdivisions of Sarasota County and the State of Florida, under the same conditions, for the same prices as this bid, unless otherwise stipulated by the Bidder.

**34. NONEXCLUSIVE CONTRACT:** Award of this Contract shall not require the City to use the Vendor for all work of this type, which may develop during the Contract term. This Contract is non-exclusive. The City reserves the right to concurrently Contract with other entities for similar work if it deems such action to be in the best interests of the City.

**35. AUDIT:** City shall have the right to audit Vendor's records that relate to this Contract. Records shall be maintained for a period of three (3) years from the date of final payment.

**36. UNAUTHORIZED ALIEN WORKERS:** The City will not intentionally award publicly-funded Contracts to any Contractor

## RFB No. 2023-04 RENOVATION OF LIFT STATIONS 29, 45 AND 73

who knowingly employs unauthorized alien workers, constituting a violation of the employment provisions contained in U.S.C. Section 1324a(e) [Section 274A(e) of the Immigration and Nationality Act (“INA”)]. The City shall consider employment by any Contractor of unauthorized aliens a violation of Section 274A(e) of the INA. Such violation by the Contractor of the employment provisions contained in Section 274A(e) of the INA shall be grounds for termination of this Agreement by the City.

**37. EMPLOYEE BACKGROUND CHECK:** If an owner, except a stockholder in a publicly traded corporation, or an employee of the Contractor has been convicted of any offenses requiring registration as a sexual offender or sexual predator, regardless of the location of conviction, the Contractor shall ensure that the offender’s or predator’s work on the project is consistent with the terms of their probation and registry requirements.

**38. PAYMENT:** One (1) original requests for payment must be submitted to the City of North Port on a form approved by the City. In lieu of the hard copies of the pay request submittal, scanned signed digital files of the requests for payments may be submitted as an attachment to an e-mail. Each pay request must be accompanied by written consent of the surety, when applicable, and an updated work schedule to reflect progress of work. Payment shall be subject to the approval and direction of the surety in accordance with F.S. §255.05(11). Price shall be net and all invoices payable according to the Florida Local Government Prompt Payment Act (F.S. ch. 218). Upon certification and approval by the City or its duly authorized agent, progress payments may be made to the Contractor upon his/her application for all services or work completed or materials furnished in accordance with the Contract. Prior to fifty percent (50%) completion, the Contractor will be paid monthly the total value of the work completed and accepted during the preceding month, less five percent (5%) retainage. After fifty percent (50%) completion of the construction services purchased pursuant to the Contract, the City the City will not reduce the amount of retainage withheld from each subsequent progress payment made to the Contractor upon request of the Contractor. For purposes of this subsection, the term “fifty percent (50%) completion” is the point at which the City has expended fifty percent (50%) of the total cost of the construction services purchased as identified in the Contract together with all costs associated with existing change orders and other additions or modifications to the construction services provided for in the Contract. The City shall inform the Contractor’s Surety of any reduction in retainage. The Contractor must update each new pay request in accordance with any changes made to the previous submittal. The City or its duly authorized administrative agent, shall approve final payment for all work, materials and services furnished under this Contract.

Retainage may be reduced upon issuance of the Certificate of Substantial Completion by the City if, in the sole opinion of the City, sufficient progress on the schedule has been accomplished, the surety does not object, and the City has retained adequate coverage for the project through the achievement of Final Completion.

**39. MBE:** Contractors awarded construction Contracts who intend to subcontract material or service requirements of the project are encouraged to subcontract to certified minority business/women business enterprises firms or show good faith effort.

**40. DBE Contract Assurance (IF APPLICABLE):** The Contractor, sub-recipient, or subcontractor shall not discriminate on the basis of race, color, national origin, or sex in the performance of this Contract. The Contractor shall carry out applicable requirements of 49 CFR Part 26 in the award and administration of DOT assisted Contracts. Failure by the Contractor to carry out these requirements is a material breach of this Contract, which may result in the termination of this Contract or such other remedy as the recipient deems appropriate.

**41. SWORN STATEMENT, COMPLIANCE WITH FLORIDA TRENCH ACT:** Bidder shall be solely responsible for complying with the Florida Trench Safety Act (553.60-553.64 Florida Statutes) and Occupational Safety and Health Administration excavation safety standards, 29 CFR 1926.650 (subpart P) as amended. All costs associated with complying with these requirements shall be included in the separate line items of the bid and shall be as detailed in the Sworn Statement of Compliance with the Florida Trench Safety Act. Bidder shall submit the Statement of Compliance with the Florida Trench



**RFB No. 2023-04 RENOVATION OF LIFT STATIONS 29, 45 AND 73**

Safety Act form provided herein with his bid or with each work assignment.

**42. INSURANCE REQUIREMENTS:** The successful Bidder shall be required to supply, at their cost, insurance coverage in form and amount as required by the City, as outlined in the bid specifications.

**43. CONTACT PROHIBITION:** All prospective Bidders are hereby instructed **NOT** to contact any member of the City of North Port Commission, the City Manager, or City of North Port staff member other than the Authorized Contact Persons identified in this Solicitation regarding this solicitation package, Bidder's submittal package, City's Intent to Award, or City's Intent to Reject (if applicable) at any time prior to the FORMAL AWARD for this project. Any such contact shall be cause for rejection of your submittal.

**44. SCRUTINIZED COMPANIES:**

A. As required by section 287.135(5), Florida Statutes, for Contracts of \$1,000,000.00 or less, when submitting a bid or proposal, and prior to entering into a Contract with the City, every person or entity shall certify on a form provided by the City, that it is not on the Scrutinized Companies that Boycott Israel List, created pursuant to section 215.4725, Florida Statutes, and that it is not engaged in a boycott of Israel.

B. As required by section 287.135(5), Florida Statutes, for Contracts of \$1,000,000.00 or more, when submitting a bid or proposal, and prior to entering into a Contract with the City, every person or entity shall certify on a form provided by the City, that all of the following are true:

1. It is not on the Scrutinized Companies that Boycott Israel List, created pursuant to section 215.4725, Florida Statutes, and that it is not engaged in a boycott of Israel: and
2. It is not on the Scrutinized Companies with Activities in Sudan list or the Scrutinized Companies with Activities in Iran Petroleum Energy Sector list, created pursuant to section 215.473, Florida Statutes: and
3. It is not engaged in business operations in Cuba or Syria.

C. PENALTY:

1. If a false certification is submitted or the person or entity has been placed on one of the above-noted Lists of Scrutinized Companies or has engaged in business operations in Cuba or Syria, the person or entity will be in breach of the Contract terms and the City may terminate the Contract.
2. A person or entity that has been found to have provided a false certification may be subject to a civil penalty equal to the greater of \$2 million or twice the amount of the Contract, plus all reasonable attorney's fees and costs, including any costs for investigations that led to the finding of the false certification: and
3. A person or entity that has been found to have provided a false certification shall be ineligible to bid on any Contract with the City for three (3) years after the date the City determined that a false certification has been submitted.

**45. CONFLICTS OF INTEREST – CITY OFFICERS, EMPLOYEES OR BOARD MEMBERS:** The Florida Code of Ethics regulates the ability of the City to Contract with its public officers (including board members), employees, and their immediate relatives. Respondents shall disclose any such potential conflicts on the provided Conflict of Interest Form. Respondents are responsible for reviewing Florida Statute §112.313 to determine whether they may have a conflict. If Respondent is in doubt as to their ability to Contract with the City, they shall seek a conflict of interest opinion from the City Manager or his/her designated representative prior to submittal of a response.

**RFB No. 2023-04 RENOVATION OF LIFT STATIONS 29, 45 AND 73**

**46. RELEASE OF LIENS:** The Contractor is required to pay all money due subcontractors and material dealers promptly. The Contractor shall submit releases of liens, satisfactory to the City, certifying that all payrolls, material bills, and other indebtedness incurred by the Contractor in connection with this project have been paid in full.

**47. DIRECT PURCHASE:** The City reserves the right, at the City's sole option, to utilize the Purchasing Department's direct purchase order system. Direct purchase orders may be issued for applicable supplies and equipment to utilize in this project in order to recover applicable sales tax on these purchase orders.

**48. E- VERIFY:** The City, contractor and every subcontractor shall register with and use the E-Verify system of the United States Department of Homeland Security to verify the work authorization status of all new employees as required by Section 448.095, Florida Statutes. A contractor who enters into a contract with a subcontractor, must require that the subcontractor provides the contractor a certification by affidavit stating that at the time of such certification and during the term of the contract, the subcontractor does not and will not employ, contract, or subcontract with an unauthorized alien, who is not authorized under federal law to be employed in the United States, as described in 8 U.S.C. S. 1324A(H)(3). The Contractor shall comply with all other federal laws pertaining to the subcontractor.

**49. BUY AMERICA:** The City is committed to the procurement of products and services that are produced or manufactured in America. The city encourages all contractors and vendors to buy American made materials and products.

**END OF SECTION I**

## SECTION II. GENERAL PROVISIONS

### 1. SCOPE OF WORK

**1.1 Intent of Contract:** Bid forms shall set forth firm bid unit prices for furnishing all necessary materials and completing all work, including but not limited to labor, transportation, supervision, electricity, water, equipment, startup, testing, training and all other work needed for a complete and operational system, as described in the Technical Specifications and/or shown on the Contract Drawings (If applicable) attached herewith. The City reserves the right to establish the exact limits of work in the field and to add or delete from the Project, as it deems necessary.

The intent of the Technical Specifications and Contract Drawings, as applicable, is to describe a complete project to be constructed in accordance with the Contract Documents. The Contract Documents comprise the entire Agreement between the City and the Contractor. They may be altered only by addendum or change order approved by the City.

#### 1.2 Definitions:

**1.2.1** The successful Bidder for this Contract will be referred to as the **CONTRACTOR**: Department Director or his/her representative, acting personally or through an assistant duly authorized for such act by the City will be referred to as City. For the purposes of this Contract, the word "Project" shall mean the services limits of **CONTRACTOR**.

**1.2.2** The Contract documents consist of the Request for Bids, Instructions to Bidders, Bid Forms, Technical Specifications, Construction Drawings, General Provisions, Special Provisions, Insurance Requirements, and all other related documents, including all modifications thereof incorporated in the documents before their execution. These form the Contract.

**1.2.3** Written notice shall be deemed to have been duly served three days after date of postmark, and upon receipt, if delivered to the individual or member of the firm or an officer of the corporation for whom it is intended.

**1.2.4** Subcontractor(s), as employed herein, includes only those having a direct Contract with the Contractor and it includes one who furnishes material worked to a special design according to the plans and specifications of this work, but does not include one who merely furnishes material not so worked.

**1.2.5** The term "work" of the Contractor includes labor or materials or both, equipment, transportation, or other facilities necessary to complete the Contract.

**1.2.6** All time limits stated in the Contract documents are of essence to the Contract.

**1.2.7** The words "furnish," furnish and install," "install," and "provide" or words with similar meaning shall be interpreted, unless otherwise specifically stated, to mean "furnish and install complete in place and ready for service."

**1.3 Time of Completion:** The Contractor shall complete the work within the time set forth in the Contract. The Contractor shall complete each portion of the work within such time as set forth in the Contract for such portion. The time of completion of the Contract shall be expressed in calendar days.

All work for this project shall be performed during regular business hours. A regular workday shall be considered to be a maximum of ten (10) hours duration. The cost for inspection time for work performed on weekends, holidays, or in excess of ten (10) hours may be billed to the Contractor at the prevailing wage plus overhead costs for those persons involved.

**A working day is** any day within the period between the start of the Contract time and the date provided in the Contract for completion or upon field acceptance by the City of all work provided for in the Contract, or as stipulated in the Technical Specifications, or whichever comes first, other than: **Saturday, Sunday, any day designated as a holiday**

**by the City, any day the Contractor is prevented from working during the first five (5) hours of the work day, with at least sixty percent (60%) of the normal work force, due to inclement weather.**

Request for planned overtime by the Contractor must be submitted in writing to the City, forty-eight (48) hours in advance, and may not proceed without the City's approval.

**1.4. Quality of Work:** The Contractor agrees to do the work covered under this Contract to the best of his/her ability and conforming to this Contract and specifications and of a quality acceptable to the trades. The Contractor further agrees to follow proper and appropriate instructions by the City.

## **2. PROSECUTION AND PROGRESS**

**2.1 Subletting or Assigning of Contracts:** The Contractor shall not sublet, sell, transfer, assign, or otherwise dispose of the Contract or any portion thereof, or his right, title, or interest therein, without written consent of the City.

**2.2 Preconstruction Meeting:** After the Contract has been awarded, the City will schedule a preconstruction meeting to be held before any work is begun to review the construction aspects of the Project. The meeting will be between the City and the Contractor.

**2.3 Performance and Payment Bond:** The awarded Contractor shall furnish a certified recorded copy from Sarasota County Clerk's Office of the Performance and Payment Bond in the amount of 100% of the total project price within ten (10) calendar days after notification of award to the Purchasing Department. The undersigned shall be responsible and bear all costs associated to record Performance and Payment Bond with Sarasota County Clerk's Office. Receipt of said recording and a certified copy of the Bond shall be furnished to the Purchasing Department at the time of the preconstruction meeting.

**2.4 Submission of Work Schedule/Order of Completion:** At the preconstruction meeting, the successful Bidder shall have on hand a working schedule for the Project, showing in detail the order in which the Contractor proposes to perform the work. He/she shall indicate the dates on which major equipment will be delivered and various major items of work will start and the estimated completion dates of the major items. Construction Schedule provides additional information for ongoing scheduling requirements associated with this Contract.

**2.5 Submission of Schedule of Values:** A Schedule of Values to reflect value of equipment, materials and work performed per unit price, with totals shall be submitted at preconstruction meeting. Both parties are to agree on proposed schedule of values prior to any work being performed.

**2.6 Provisions for Convenience of Public:** The Contractor shall schedule his/her operations so as minimize any inconvenience to adjacent businesses for residences. Where necessary, the City may require the Contractor to construct first the work in any areas along the Project where restrictions caused by construction operations would represent a more serious handicap, before beginning construction in the less affected areas.

## **3. CONTROL OF THE WORK AND MATERIALS**

### **3.1 Control of Work:**

**3.1.1 Plans and Contract Documents:** If required for the project, the Contractor will be furnished a universal serial bus flash drive and four (4) signed and sealed building permit 11"x17" copies of the Plans, Technical Specifications, General and Special Provisions. Additional signed & sealed copies, if needed to obtain permits for the Work associated with this Contract, will be submitted upon written request. Other copies that may be needed by the Contractor shall be produced by the Contractor at his own expense.

**3.1.2 Detail Drawings and Instructions:** The City may furnish, with reasonable promptness, additional instructions by means of drawings or otherwise, necessary for the proper execution of the work. All such drawings and instructions shall be consistent with the Contract documents, true developments thereof, and reasonably inferable there from.

**3.1.3 Order of Precedence:** These documents are integral parts of the Contract, and a requirement occurring on one is as binding as though occurring in all. They are intended to be complementary and to describe and provide for a complete work. In cases of discrepancy, the governing order of documents shall be as follows:

- 3.1.3.1** Permits from Agencies as required by law
- 3.1.3.2** Change Orders
- 3.1.3.3** Contract Documents, General Provisions and Special Provisions in that order
- 3.1.3.4** Technical Specifications
- 3.1.3.5** Construction Plans
  - 3.1.3.5.1** Dimensions given in figures govern scaled dimensions.
  - 3.1.3.5.2** Detail drawings govern over general drawings.
  - 3.1.3.5.3** Addenda/Change order drawings govern over Contract documents.
- 3.1.3.6** FDOT Roadway and Traffic Design Standards, January, latest edition (if applicable).
- 3.1.3.7** FDOT Standard Specifications, for Road & Bridge Construction, latest edition (if applicable).
- 3.1.3.8** North Port Utilities Standard Details and Specifications

**3.1.4 Conformity of Work with Plans:** All work performed and all materials furnished shall be in reasonably close conformity with lines, grades, cross sections, dimensions, and material requirements, including tolerances, shown on the Plans or indicated in the Technical Specifications or Special Provisions.

**3.1.5 Authority of the City:** All work shall be done under the supervision of the City or the City's representative and performed to its satisfaction. It is agreed by the parties hereto that the City shall decide all questions and disputes which may arise relative to the interpretation of the plans, construction, prosecution, and fulfillment of the Contract, and as to the character, quality, amount, and value of any work done, and material furnished, under or by reason of the Contract.

**3.1.6 City's Status:** The City and/or the City's Representative shall examine and inspect the work to assure compliance with the requirements of these Contract Documents. The City and/or the City's Representative shall determine the quality and acceptability of materials and workmanship relative to the requirements of the Plans and Technical Specifications.

**The City has the authority to:**

- 3.1.6.1** Stop the work whenever such stoppage may be necessary to insure the proper execution of the Contract.
- 3.1.6.2** Reject all work that does not conform to the Contract.
- 3.1.6.3** Resolve questions that arise in the execution of the work.

**The City's Representative has the authority to:**

- 3.1.6.4** Reject all work that does not conform to the Contract.
- 3.1.6.5** Resolve questions that arise in the execution of the work.

**3.1.7 Suspension of Work:** The City may at any time suspend work by giving ten (10) calendar days notice to the Contractor in writing. The City shall reimburse the Contractor for expenses incurred by the Contractor in connection with work under the Contract as a result of such suspension, unless such suspension was caused by actions of the Contractor. However, if the work or any part thereof shall be stopped by a notice in writing aforesaid, and if the City does not give written notice to the Contractor to resume work within thirty (30) calendar days of the date fixed in the written notice to suspend, then the Contractor will be entitled to the estimates and payment for all work done, unless such suspension was caused by actions of the Contractor.

**3.1.8 The City's Right to do Work:** If the Contractor should neglect to prosecute the work properly or fail to perform in accordance with the provisions of this Contract, the City, after three days written notice, may without prejudice to any other remedy it may have, make good any deficiencies and deduct from the payment due the Contractor.

**3.1.9 The City's Right to Terminate Contract:** If the Contractor refuses or fails to complete the work within the time specified for this Contract, or any extension thereof, the City may terminate the Contractor's right to proceed. In such event, the City may take over the work and prosecute the same to completion by the Contract or otherwise and the Contractor will be liable for any excess cost occasioned by the City. The City may take possession of and utilize in completing the work such materials and equipment as may be on the site of the work and necessary, therefore:

If the Contractor should be adjudged bankrupt, or should make a general assignment for the benefit of his/her creditors, or if a receiver should be appointed due to insolvency, or if he/she should refuse or fail, except in cases which a time extension is provided to supply enough personnel, or if he/she should fail to make payment to subcontractors for labor and/or material, or disregard laws, ordinances or the instructions of the City, or be guilty of a violation of a provision of the Contract, then the City may, without prejudice to any other right or remedy and after giving seven (7) calendar days' notice, terminate employment of the Contractor and possess materials, tools, and appliances thereon and finish work by methods it may deem expedient. Expenses incurred by the City and the damage incurred through the Contractor's default shall be borne by the Contractor.

In any circumstance, the City shall have the right to unilaterally cancel, terminate or suspend this Contract, in whole or in part, by providing the Contractor thirty (30) calendar days written notice by certified mail.

In the event of termination, the Contractor shall be entitled to compensation for services rendered and costs incurred through the effective date of termination. All finished or unfinished documents, material, or work shall become the property of the City and shall be delivered to the City without reservation.

**3.1.10 City May Stop the Work:** If the Work is defective, or the Contractor fails to supply sufficient skilled supervisory personnel or workers or suitable materials or equipment or the work area is deemed unsafe, the City may order the Contractor to stop the Work, or any portion thereof, until the cause for such order has been eliminated: however, this right of the City to stop the Work shall not give rise to any duty on the part of the City to exercise this right for the benefit of the Contractor or any other party. The City will not award any increase in Contract Price or Contract Time if the Work is stopped due to the circumstances described herein.

**3.1.11 City's Decision:** The City shall, within a reasonable time after their presentation, make decisions in writing on claims by the Contractor and on all other matters relating to the execution and progress of the work or the interpretation of the Contract Documents.

**3.1.12 Authority and Duties of City's Inspectors:** The City's Inspectors shall be authorized to inspect all work done and all materials furnished. They shall be authorized to call to the attention of the Contractor any failure

of the work or materials to conform to the Technical Specifications and Contract. The presence of the Inspector shall in no way lessen the responsibility of the Contractor.

**3.1.13 Inspection of Work:** The City and its representative shall at all times have access to the work wherever it is in preparation or progress and the Contractor shall provide proper facilities for such access and inspection. If the Specifications/Conditions, the City's instruction, laws, ordinances or any public authority require any work to be specially tested or approved, the Contractor shall give to the City timely notice of its readiness for inspection and, if the inspection is by an authority other than the City, the date fixed for such inspection. Inspections by the City shall be promptly made and, where practicable, at the source of supply. If any work should be covered up without approval or consent of the City, it must, if required by the City, be uncovered for examination at the Contractor's expense. Re-examination of questioned work may be ordered and the work must be uncovered by the Contractor.

**3.1.14 Contractor's Supervision and Employees:** The Contractor shall supervise, inspect, and direct the work completely and efficiently, devoting such attention thereto and applying such skills and expertise as may be necessary to perform the work in accordance with the Contract Documents. The Contractor shall be solely responsible for the means, methods, techniques, sequence and procedures necessary for the orderly progress of the work, and to maintain all safety precautions and programs incidental thereto. The Contractor shall at all times enforce strict discipline and good order among his/her employees and shall not employ any unfit person or anyone unskilled in the work assigned to him/her. The Contractor shall be responsible to see that the completed work complies fully with the Contract Documents.

The Contractor will employ and maintain on the Work a qualified supervisor or superintendent who shall have been designated in writing by the Contractor as the Contractor's representative at the site. The supervisor shall have full authority to act on behalf of the Contractor and all communications given to the supervisor shall be as binding as if given to the Contractor.

As the work progresses, the Contractor shall keep on the job at all times an English-speaking Supervisor, Superintendent or designee, technically qualified, who is an employee of the Contractor and who shall not be replaced without written notice and approval of the City. The Superintendent or his/her qualified designee shall be present at the job site and direct the work of subcontractors, as well as employees of the Contractor. This supervisor will be equipped with a communication device enabling him/her to contact suppliers, subcontractors or his/her office who in turn can convey necessary communications to others. The Contractor shall issue all communications to the City or his/her representative.

The Contractor's Superintendent shall be present on the job site **at all times** while work is in progress and shall be available by phone for emergencies twenty-four hours per day, seven days per week. Failure to observe this requirement shall be considered suspension of the work by the Contractor until such time as such Superintendent is again present on the job.

If the Contractor, in the course of the work, finds any discrepancy between the drawing and the physical conditions of the site, or any errors or omissions in drawing, or in the construction layout points and instructions, he/she shall immediately inform the City, in writing, and the City shall promptly verify same. Any work done after such discovery will be done at the Contractor's risk.

Neither party shall employ or hire any employee of the other party without the concurrence of each party.

**3.1.15 Contractor's Understanding:** It is understood and agreed that the Contractor has, by careful examination, satisfied himself/herself as to the nature and locations of the work, the conformation of the

ground, the character, quality, and quantity of materials to be encountered, the character of equipment and facilities needed prior to and during prosecution of the work under this Contract. No verbal agreement or conversation with any officer, agent, or employee of the City, either before or after execution of this Contract, shall affect or modify the terms or obligations herein contained.

**3.1.16 Permits and Regulations:** Permits and licenses necessary for the prosecution of the work shall be secured by the Contractor unless otherwise specified. The Contractor shall give all notices and comply with all laws, ordinances, rules, and regulations bearing on the conduct of the work as drawn and specified. If the Contractor observes that the specifications and drawings are at variance therewith, Contractor shall promptly notify the City in writing, and any necessary changes shall be adjusted as provided in the Contract for changes in the work. If the Contractor performs any work knowing it to be contrary to such laws, ordinances, rules, and regulations, and without such notice to the City, he/she shall bear all costs arising there from.

**3.1.17 Protection of Work and Property:** The Contractor shall continuously maintain protection of all his/her work from damage and shall protect the City's property from injury or loss arising in connection with this Contract. He/she shall adequately protect adjacent property as provided by law and the Contract Documents. He/she shall provide and maintain all passageways, guard fences, lights, and other facilities for protection required by public authority or local conditions. In an emergency affecting the safety of life or of the work, or of adjoining property, the Contractor, without special instruction or authorization from the City, is hereby permitted to act, at their discretion, to prevent such threatened loss or injury, and he/she shall so act, without appeal, if so instructed or authorized. Any compensation claimed by the Contractor on account of emergency work shall be determined by agreement between the Contractor and the City.

The Contractor shall not occupy private land outside of any easements or rights of way unless a written authorization has been signed by the property owner. It shall be the Contractor's responsibility to obtain and provide these agreements prior to construction, if required. Prior to the use of private lands, the Contractor shall submit a copy of the agreement(s) to the City. In the event the Contractor uses private property for any purpose without first having obtained the necessary approvals from the property owner and provided the necessary agreements to the City, the City will direct the Contractor in writing to immediately cease using such property.

Prior to application for final payment, the Contractor shall provide documentation from the owner of each piece of private property for which an agreement for use was provided, or for which the City has issued written notification to the Contractor, that each owner is satisfied with the manner in which the Contractor has restored the property. Final payment or reduction in retainage shall not be paid until such documentation is received by the City.

**3.1.18 Changes in the Work:** The City, without invalidating the Contract, may order extra work or make changes by altering, adding to or deducting from the work, the Contract sum being adjusted accordingly. Such work shall be executed under the conditions of the original Contract. The change and amount of compensation must be agreed upon in writing in a document of equal dignity herewith prior to any deviation from the terms of this Contract.

In giving instructions, the City shall have authority to make minor changes in the work, not involving extra cost, and not inconsistent with the purposes of the work. Except in an emergency endangering life or property, no extra work or change shall be made unless in pursuance of a written order by the City: and no claim for an addition to the Contract sum shall be valid, unless ordered. Value of any such extra work or change shall be determined in one or more of the following ways:



**RFB No. 2023-04 RENOVATION OF LIFT STATIONS 29, 45 AND 73**

- 3.1.18.1** By estimate and acceptance in a lump sum.
- 3.1.18.2** By unit prices named in the Contract or subsequently agreed upon.
- 3.1.18.3** By cost and percentage or by cost and a fixed fee.

If none of the previous methods are agreed upon, the Contractor, provided he/she receives an order as above, shall proceed with the work. In such case and also under case, he/she shall keep amendment in such form as the City may direct, a correct amount of the net cost of labor and materials, together with vouchers. The City shall certify to the amount, including reasonable allowance for overhead and profit, due to the Contractor. Pending final determination of value, no payment on changes shall be made. When requiring a change in the scope of services the Contractor shall notify the City by written notice that a change order is requested within five (5) days of any occurrence.

**3.1.19 *Deductions for Uncorrected Work:*** If the City deems it inexpedient to correct work injured or done not in accordance with the Contract, some equitable deductions from the Contract price shall be made thereof.

**3.1.20 *Delays and Extension of Time:*** If the Contractor should be delayed at any time in the progress of work by any act of negligence by the City or its employees or by any other Contractor employed by the City, or by changes ordered in the work, or by such causes beyond the Contractor's control, or by delay authorized by the City, or by any cause which the City shall decide to justify the delay, then the time of completion shall be extended for such reasonable time as the City may decide. However, no time delay shall be allowed if judged by the City to be caused by the Contractor's negligence.

No such extension shall be made for delay occurring more than seven (7) calendar days before claim therefore is made in writing to the City. In the case of a continuing cause of delay only one (1) claim is necessary. This article does not exclude the recovery of damages for delay by either party under other provisions in the Contract Documents.

**3.1.21 *Correction of Work Before Final Payment:*** All work, materials, whether incorporated in the work or not, all processes of manufacturer, and all methods of construction shall be at all times and places subject to the inspection of the City who shall be the final judge of quality and suitability of the work, materials, processes of manufacture, and methods of construction for the purposes for which they are used. Should they fail to meet City's approval: they shall be forthwith reconstructed, made good, replaced, and/or corrected, as the case may be, by the Contractor at his/her own expense. Rejected material shall be immediately removed from the site. If, in the opinion of the City, any portion of the work injured or not performed in accordance with the Contract Documents, the compensation to be paid to the Contractor hereunder shall be reduced by such amount as the City, in its judgement, finds to be equitable.

**3.1.22 *Contractor Right to Stop Work or Cancel Contract:*** If the work should be stopped under an order of any court or other public authority for a period of three (3) months through no act or fault of the Contractor or of anyone employed by him, or if the City fails to pay the Contractor within thirty (30) calendar days of maturity and presentation of any sum certified by the City, then the Contractor may, upon seven (7) calendar days written notice to the City, stop work and terminate this Contract.

**3.1.23 *Removal of Equipment:*** In the case of annulment of this Contract before completion from any cause whatever, the Contractor, if notified to do so by the City, shall promptly remove any part or all of his equipment and supplies from property of the City and/or site of work, failing which the City has the right to remove such equipment and supplies at the Contractor's expense.

**3.1.24 Use of Completed Portions:** The City has the right to take possession of and use any completed or partially completed portions of the work, notwithstanding the time for completing the entire work of such portions may not have expired, but taking possession and use shall not be deemed an acceptance of any work not completed in accordance with the Contract Documents. If such prior use increases the cost of or delays the work, the Contractor shall be compensated as the City may determine and the City approves.

**3.1.25 Payments Withheld:** The City may withhold payment to the Contractor from loss on account of:

**3.1.25.1** Defective Work not remedied.

**3.1.25.2** Claims filed or evidence indicating probable filing of claims.

**3.1.25.3** Failure of the Contractor to make payment properly to Subcontractors or for material/labor.

**3.1.25.4** A reasonable doubt that the Contract can be completed for the balance then unpaid.

**3.1.25.5** Damage to another Contractor.

**3.1.26 Damages:** Any claim for damage arising under this Contract shall be made in writing to the party liable within a reasonable time of the first observance of such damage and not later than the time of final payment, except as expressly stipulated otherwise in the case of faulty work, and shall be adjusted by agreement.

**3.1.27 Assignment:** Neither party to the Contract shall assign the Contract or sublet it as a whole without the written consent of the other, nor shall the Contractor assign any monies due or to become due to him/her hereunder without the previous written consent of the City.

**3.1.28 Right of Various Interests:** Before work being done by the City's forces or by other Contractor's forces, contiguous to work covered by this Contract, the respective rights of the various interests involved shall be established by the City before such commencement, to secure the completion of the various portions of the work in general harmony.

**3.1.29 Separate Contracts:** The City reserves the right to let other Contracts in connection with this work. The Contractor shall afford other Contractors reasonable opportunity for the introduction and storage of their materials and execution of the work and shall properly connect and coordinate his/her work with theirs. If any part of the Contractor's work depends on proper execution or results upon the work of any other Contractor, the Contractor shall inspect and promptly report to the City any defects in such work that render it unsuitable for such proper execution and results. His/her failure to so inspect and report shall constitute an acceptance of the other Contractor's work as fit and proper for the reception of his work, except as to defects, which may develop on the other Contractor's, work after execution of his work.

**3.1.30 Subcontractors:** The Contractor shall provide a list of Subcontractors with his/her proposal for approval. The Contractor shall be fully responsible for all acts and omissions of his Subcontractors and of persons and organizations directly or indirectly employed by them and of persons and organizations for whose acts any of them may be liable to the same extent that Contractor is responsible for the acts and omissions of persons directly employed by Contractor. Nothing in the Contract Documents shall create any Contractual relationship between City or City's Engineer of Record and any Subcontractor or other person or organization having a direct Contract with Contractor, nor shall it create any obligation on the part of City or City's Engineer of Record to pay or to see to the payment of any moneys due any Subcontractor or other person or organization, except as may otherwise be required by law. City or City's Engineer of Record may furnish to

## RFB No. 2023-04 RENOVATION OF LIFT STATIONS 29, 45 AND 73

any Subcontractor or other person or organization, to the extent practicable, evidence of amounts paid to Contractor on account of specific Work done in accordance with the schedule of values.

Substitutions must be submitted in writing and shall be subject to the approval by the City. To ensure proper execution of his/her subsequent work, the Contractor shall measure work already in place and shall at once report to the City any discrepancy between the executed work and the drawings.

Acceptance of any such Subcontractor, person or organization shall not constitute a waiver of any right of the City, City's Representative, or Engineer to reject defective Work, material or equipment: or, Work, material or equipment not in conformance with the requirements of the Contract Documents.

The divisions and sections of the Specifications and the identifications of any Drawings shall not control the Contractor in dividing the Work among Subcontractors or delineating the Work to be performed by any specific trade.

The Contractor agrees to bind specifically every Subcontractor to the applicable terms and conditions of the Contract Documents for the benefit of the City.

All Work performed for the Contractor by a Subcontractor shall be pursuant to an appropriate agreement between the Contractor and the Subcontractor.

The Contractor shall be responsible for the coordination of the trades, Subcontractors and suppliers engaged upon his Work.

- The Contractor shall cause appropriate provisions to be inserted in all subcontracts relative to the Work to bind Subcontractors to the Contractor by the terms of these General Conditions and other Contract Documents insofar as applicable to the Work of Subcontractors, and to give the Contractor the same power in regard to terminating any subcontract that the City may exercise over the Contractor under any provisions of the Contract Documents.
- The City, City's Representative, or Engineer will not undertake to settle any differences between the Contractor and his Subcontractors or between Subcontractors.
- If in the opinion of the City, City's Representative, or Engineer, any Subcontractor on the Project proves to be incompetent or otherwise unsatisfactory, Subcontractor shall be replaced if and when directed in writing.

**3.1.31 *Horizontal and Vertical Control:*** Unless noted otherwise in the Contract documents, the Contractor shall be responsible for the layout of all Contract work. The Contractor shall employ or retain any/all professional services that are required by the Contract to complete the work. The Contractor shall carefully preserve benchmarks, reference points and stakes, and, in case of willful or careless destruction, be responsible for any mistakes that may be caused by their unnecessary loss or disturbance.

**3.1.32 *Lands for Work:*** The City shall provide the lands upon which the work under this Contract is to be done, except that the Contractors shall provide land required for the erection of temporary construction facilities and storage of material, together with the right of access to same.

**3.1.33 *Cleaning Up:*** The Contractor shall, at such times as may be required by the City, remove from the City's property and from all public and private property, at his/her own expense, all temporary structures, used materials and equipment, rubbish and waste materials resulting from his/her operations. All damaged areas will be restored by the Contractor to their original conditions and approved by the City. By submission of a bid, the Contractor assumes full responsibility for the associated expenses. There shall not be an increase

in time or price associated with such removal, and payment to Contractor may be withheld until such work is completed.

**3.1.34 *Guarantee:*** The Contractor shall warrant all equipment furnished and work performed by him/her for a period of one (1) year from the date of written acceptance of the work, final completion by the City or as may be otherwise specified. Any faulty work or equipment will be fully corrected at no cost to the City and restored work will be warranted for one year from the date of acceptance, or as may be otherwise specified. This will not release additional warranties required by other sections or provided by individual suppliers.

The making and acceptance of final payment shall not waive any claim for faulty work appearing after final payment or for failure to adhere strictly to the Contract documents. If any part of the project is guaranteed for a longer period, such longer period shall prevail. Except as otherwise specified, all work shall be guaranteed by the Contractor against defects resulting from use of inferior materials, equipment or workmanship for one (1) year from the date of completion or written acceptance by the City, whichever is later.

**3.1.35 *Responsibility Regarding Existing Utilities and Structures:*** The existence and location of underground utilities indicated on the plans are not guaranteed and shall be investigated and verified in the field by the Contractor before submitting a bid. Excavation in the vicinity of existing structures and utilities shall be done by hand. The Contractor shall be responsible for any damage to, and for maintenance and protection of, existing utilities and structures from any damage resulting from said excavation. The Contractor is to include within his line-item bid prices the costs to protect, support, relocate, or move (whether shown or not shown on the proposed project set of plans) all underground utilities, which may be in conflict with the construction of the proposed project.

**3.1.36 *Accidents:*** The Contractor shall provide equipment and medical facilities as necessary to supply first aid to anyone who is injured in connection with the work. The Contractor must promptly report in writing to the City accidents arising out of, or in conjunction with the performance of the work, whether in, or adjacent to, the site, which causes death, personal injury, or property damages, giving full details and statements of witnesses. If death or serious injuries or serious damages are caused, the accident shall be reported immediately by telephone or messenger to the City. If a claim is made by anyone against the Contractor or Subcontractor on account of an accident, the Contractor shall promptly report the facts in writing to the City, giving full details of the claim.

**3.1.37 *Stage Plans:*** Stage plans of structural alterations, cofferdams, dredging, furnished or approved by the City, shall be adhered to unless objected to in writing by the Contractor, but the submission or approval of stage plans by the City shall not relieve the Contractor of full responsibility for the work.

**3.1.38 *Measurement of Quantities:*** The quantities of work performed will be computed by the City on the basis of measurement taken by the City or its assistants, and these measurements shall be final and binding. All work computed under the Contract shall be measured by the City according to the United States Standard Measurement and Weights. The City does not assume any responsibility that the final quantities will remain in accord with estimated quantities, nor shall the Contractor claim misunderstanding or deception because of such estimate of quantities.

The estimated quantities of work to be done and material to be provided may be increased, decreased, or omitted, as provided herein. Any increase in quantities shall be approved by the City prior to any work.

**3.1.39 *Reference to Other Specifications:*** Where reference is made to specifications such as ASTM, AWWA or AASHTO, the latest edition shall be used.

**3.1.40 Sanitary Facilities:** The Contractor shall provide and maintain, in a sanitary condition, facilities for his/her employees as are required by local and state boards of health.

**3.1.41 Quality of Equipment and Materials:** To establish standards of quality, the City may, in the specifications, refer to products by name and/or catalog number. This procedure is not to be construed as eliminating from competition other products of equal quality by other manufacturers where fully suitable in design.

**3.1.41.1** The Contractor shall furnish a complete list of proposed desired substitutions prior to signing of the Contract together with such engineering and catalog data as the City may require.

**3.1.41.2** The Contractor shall abide by the City's judgment when proposed substitute items of equipment are judged unacceptable and shall furnish the specified item of equipment in such case. All proposals for substitutions shall be submitted in writing by the General Contractor. The City will approve or disapprove proposed substitutions in writing within a reasonable time.

**3.1.42 Codes and Laws:** The successful Bidder shall comply with all Federal, State, Local Laws and Ordinances that affect the Contract in any way.

**3.1.43 Traffic Control:** The Contractor shall comply with the National Committee on Uniform Traffic Control and Devices (NCUTCD) standards established by the Federal Highway Commission and the most current FDOT Standards for Traffic Control Through Work Zones and maintain safe conditions at all times.

**3.1.44 Exploration and Reports:** If reference is made to identification of reports of explorations and tests of subsurface, or other project specific, conditions at the site that have been used in preparing the Contract documents, it should be understood that these reports are not part of the Contract documents. The Contractor shall have full responsibility with respect to subsurface, or other project specific, conditions at the site. Technical data, made available only at the Contractor's request, may not be sufficient for construction purposes. Additional investigations may be necessary for the purposes of carrying out the construction project. If the Contractor desires additional subsurface, or other applicable project specific, investigation, it will be done at his/her expense, prior to bidding. Limited Subsurface, or other project specific, reports for this project are available through North Port Department of Public Works.

If the Contractor has elected not to make subsurface, or other project specific, investigation prior to bidding, he/she shall not be entitled to any extra compensation or Contract change orders due to conditions encountered.

**3.1.45 Existing Structures:** Drawing of physical conditions in or relating to existing surface and subsurface structures which are at or contiguous to the site that have been utilized by the consultant and/or the City in preparation of the Contract documents. The Contractor may rely upon the accuracy of the technical data contained in such drawing but not for the completeness thereof for the purpose of preparing or submitting a bid. Except as previously indicated, the Contractor shall have full responsibility with respect to physical conditions in or relating to such structures.

**3.1.46 Report of Differing Conditions:** If the Contractor believes that any technical data on which he/she relies is inaccurate, or if any physical conditions uncovered or revealed at the site differ materially from that indicated, reflected, or referred to in the Contract documents, the Contractor shall promptly, after becoming aware and before performing any work in connection therewith (except in emergency situations), notify the City in writing about the inaccuracy of difference. The City will promptly review the pertinent conditions, determine the necessity of obtaining additional explorations or tests with respect thereto and advise the City in writing (with a copy to the Contractor) of the City's findings and conclusion. Contractor's cost of, or the time

## RFB No. 2023-04 RENOVATION OF LIFT STATIONS 29, 45 AND 73

required for, performance of any part of the work under this Contract, whether or not changed as a result of such conditions, an equitable adjustment shall be made and the Contract modified in writing accordingly.

No claim of the Contractor under this clause shall be allowed unless the Contractor has given the notice required: provided, however, the time prescribed therefore may be extended by the City.

No claim by the Contractor for an equitable adjustment hereunder shall be allowed if asserted after final payment under this Contract.

**3.1.47 Not Shown or Indicated:** If an underground facility is uncovered or revealed at or contiguous to the site, which was not shown or indicated and of which the Contractor could not reasonably have been expected to be aware, the Contractor shall promptly, before performing any work (except in emergencies), identify the owner of such underground facility and give written notice thereof to that owner and to the City. The Contractor will review the underground facility to determine the extent to which the documents should be modified to reflect and substantiate the consequences of the existence of the underground facility. With City approval, the Contract documents will be amended or supplemented to the extent necessary. During such time, the Contractor shall be responsible for the safety and protection of such underground facility. The Contractor shall be allowed an increase or an extension of time, or both, to the extent that they are attributable.

**3.1.48 Progress Meeting:** Progress meetings will be conducted bi-weekly or as required if requested by Contractor or the City.

### **3.2 Storage of Materials**

**3.2.1** Contractor shall, at its expense, receive, unload, store in a secure place, and deliver from storage to the construction site all materials and equipment required for the performance of the Contract.

**3.2.2** Contractor is not entitled to payment for same except for those materials which in City's discretion are properly stored and are going to be installed or incorporated into the construction of the Project within thirty (30) days of delivery to the construction site.

**3.2.3** The storage facilities and methods of storing shall meet City's approval and shall be in accordance with manufacturer's recommendations, or City will not be obligated to pay for same.

**3.2.4** Materials and equipment subject to degradation by outside exposure shall be stored in a weather tight enclosure provided by Contractor at its expense.

**3.2.5** City may at its discretion require material to be stored in an air-conditioned location.

**3.2.6** Provided the above conditions are met, the stored materials may be included in a subsequent

**3.2.7** Application for Payment if the Contractor also complies with the following:

**3.2.7.1** An applicable purchase order is provided listing the materials in detail and identifying the Contract Documents, by name, with verification that the total value of the purchase order amount reconciles with the corresponding application for payment stored materials line item value.

**3.2.7.2** Evidence that proper storage security is provided.

**3.2.7.3** The City is provided legal title (free of liens or encumbrances of any kind) to the material that is stored or stockpiled.

**RFB No. 2023-04 RENOVATION OF LIFT STATIONS 29, 45 AND 73**

**3.2.7.4** The Contractor and/or its Subcontractor have provided insurance for the Stored Materials against loss, damage (from whatever source), or disappearance, including loss or theft prior to incorporation into the Work. By execution of the Contract, Contractor releases City from any responsibility for Stored Materials and assumes all liability for and risk of loss or damage, by whatever means, including City's alleged negligence, regardless of whether the City has paid for said Stored Materials.

- 3.2.8** Once any Stored Material is paid for by City, it shall not be removed from the designated storage area except for incorporation into the Work or upon subsequent written approval by City.
- 3.2.9** No Applications for Payment shall be submitted nor payments made based on the value of materials stored at locations other than the Project, unless otherwise approved in writing by the City.
- 3.2.10** It is further agreed between the parties that the transfer of title and the City's payment for any Stored Material pursuant to the Contract Documents shall in no way relieve the Contractor of the responsibility for providing and installing such material in accordance with the requirements of the Contract Documents.
- 3.2.11** The Contractor warrants that title to all of the Work or Stored Materials covered by the Application for Payment will pass to the City either by incorporation in the Project or upon receipt of payment by the Contractor, whichever occurs first, free and clear of all liens, claims, security, interest or encumbrance: and that none of the Work and none of the Stored Materials covered by the Application for Payments will have been acquired by the Contractor, or by any other person performing the Work at the site or providing materials and equipment to the Project, subject to an agreement under which an interest therein or encumbrance thereon is retained by the seller or otherwise imposed by the Contractor or such person.
- 3.2.12** In the event stored materials which the City is paying for in advance of their being installed or incorporated into the Project pursuant to this Paragraph are not installed or incorporated into the Project within thirty (30) days of when they are delivered to the site, Contractor shall not be entitled to payment for any future stored materials on this Project and the amounts previously approved for payment for said materials shall be deducted from the Contractor's next application for payment.

**END OF SECTION II**

**SECTION III.  
SPECIAL PROVISIONS**

**SP-01 INTENT:** The purpose of this project is to obtain a competent, experienced and responsible Contractor to construct the project in accordance with the plans and specifications, in an expeditious manner that reasonably protects the public and adjacent property from the construction of the project.

The Contract Documents comprise the entire agreement between City and Contractor concerning the work. The Contract Documents are complementary; what is called for by one is as binding as if called for by all. The Contract Documents will be construed in accordance with the law of the place of the project. The work specified herein shall consist of furnishing all supervision, labor, equipment, material and any incidentals required for the successful completion of all work as specified herein. All work shall conform within the limits as specified and shown and be in conformance with the appropriate Technical Specifications contained herein.

The plans, technical specifications, and other documents provided are intended to provide the Contractor with known conditions of the existing site and proposed work area. The Contractor is responsible to conduct any and all investigation, survey, or other activities required to fully understand the existing site and conditions that will be encountered during the project, and on which their bid will be based. Additional investigations may be necessary for the purposes of carrying out the construction project. The City of North Port will not consider or approve any claim for additional time or monetary compensation submitted by the Contractor caused by unknown site conditions or a failure by the Contractor to fully investigate and understand the full extent and nature of the work. This includes, but is not limited to, existing utilities as well as subsurface conditions.

**SP-02 EQUIPMENT:** The Contractor shall only use equipment, machines, or combination of machines that are in good and safe working condition. The equipment shall produce results that meet or exceed the Technical Specifications stated herein.

Equipment incapable of providing this will not be acceptable for use on this Project. The Contractor shall not use equipment which is unsafe or in need of repair. Work completed with equipment, which is not properly functioning, shall be deemed unacceptable.

**SP-03 CONSTRUCTION SCHEDULE:** The work will be substantially complete within **180 calendar days** with final completion within **30 calendar days** after attaining Substantial Completion as established by the City. The date for **Final Completion** of the Project shall be established as **210 calendar days after** Notice to Proceed.

The Contractor shall furnish copies of the Construction Schedule to the City when requested to perform the work as outlined in the Bid Form. The City will notify the Contractor of such as needed work and the Contractor will provide a Construction Schedule to the City within thirty (30) days of the City's notification. A project update meeting will be held bi-weekly, or as required during contract.

**SP-04 PRE-CONSTRUCTION CONFERENCE:** A Pre-Construction Conference will be held, at which time the Contractor shall submit the following for the City's approval or acceptance:

A telephone list specifying the name, address, office phone number and cell phone numbers of all subcontractors or suppliers to be used on this project. If the Contractor proposes to subcontract any survey work that may be required, the Contractor shall include the registration number of the surveyor. The telephone list shall also include emergency telephone numbers. The Contractor shall include a 24-hour emergency telephone for the City's use, which the Contractor shall update as necessary throughout the



**RFB No. 2023-04 RENOVATION OF LIFT STATIONS 29, 45 AND 73**

project. The Contractor shall request, in writing, any changes in subcontractors or suppliers.

No change in subcontractors or suppliers shall be made without written consent and approval from the City.

- In addition to the telephone and facsimile numbers, the Contractor shall provide an e-mail address where emails can be sent. The e-mail address must be monitored at least daily and capable of transferring electronic files.
- The Contractor shall submit to the City a list of equipment the Contractor proposes to utilize on this project.
- The Contractor shall submit for City approval a paper copy and electronic copy of a Construction Schedule prepared using City approved software, and a Schedule of Progress Payment Requests.
- The Contractor shall also submit all other materials or mix designs, which will be used by the Contractor for this Contract.

**Mobilization may not start** until all submittals have been accepted by the City and/or City's Representative. Once approved, no changes will be allowed without the written approval of the City and/or the City's Representative.

The Contractor shall also provide, on a monthly basis, an update to the Construction Schedule reflecting changes made as a result of such reasons as weather, breakdowns, and unanticipated delays, as a means of better monitoring the project.

**SP-05 PROGRESS MEETING:** For this project, progress meetings shall be bi-weekly, or as requested by the Contractor or the City. The Contractor shall designate a representative to attend Progress Meetings held at the North Port Utilities Field Office, 6644 West Price Boulevard, North Port, Florida. The Contractor shall submit, at each meeting, up-to-date schedule information, a written projected schedule for the next two weeks, written claims for additional compensation, written claims for weather days to extend the Contract, results of all testing and Value Engineering Proposals. The City will use the updated schedule information to monitor the Contractor's production rate. Upon written notice from the City, the Contractor shall dedicate additional resources to increase the production rate such that the Contractor will be back on schedule. Failure to comply with the approved Construction Schedule shall result in the Contractor being considered in default and subject to suspension of this Contract. Contractor may request progress meetings be on a different schedule than bi-weekly provided the City can confirm work is proceeding expeditiously. City may require a return to bi-weekly progress meetings at any time.

**SP-06 COOPERATION WITH UTILITIES:** The Contractor shall notify all utility owner(s) affected by the construction prior to beginning work. Any expense of utility repair or other damage due to Contractor's operations shall be borne by the Contractor. Protection of utilities shall be the responsibility of the Contractor, who shall provide adequate protection to maintain proper service.

**NOTE: The Contractor is to include within his bid prices, the costs to protect, and/or support, all above ground, overhead and underground utilities, which may be in conflict with the construction of this proposed project.**

Attention is called to the Florida Underground Facility Damage Prevention and Safety Act defined in Florida Statute. This act provides for a "One Call Toll Free" telephone number to be used by all parties doing excavation, demolition or other underground construction.

**SP-07 CONTRACT TIME:** The Contractor specifically agrees that it will commence operations within a mutually agreed upon time following notification by the City to commence work and that all work to be performed under the provisions of this Contract shall be completed not more than **210 calendar days after** Notice to Proceed; subject only to delays caused through no fault of the Contractor or acts of God. Time is of the essence in the performance of this Contract. The contract time includes up to fourteen (14) calendar days for City and/or City's Engineer of Record

**RFB No. 2023-04 RENOVATION OF LIFT STATIONS 29, 45 AND 73**

review of each submittal and resubmittal. There shall be no extension of time provided for modification and corrections or re-submittals to address deficiencies therein identified during the review by the City and/or City's Engineer of Record.

The work will be substantially complete within **180 calendar days**; with final completion within **30 calendar days** after attaining Substantial Completion as established by the City. City shall provide the Contractor with a listing of items to be corrected or completed (punch list) after Substantial Completion is issued. The punch list will identify the remaining items that must be addressed to the satisfaction of the City by the Contractor to meet his/her obligations under the Contract. The Contractor shall complete all items on the punch lists to the satisfaction of the City prior to submittal of the application for final payment.

All extensions to the Contract time for permitted delays shall be by Change Order and signed by the City.

**SP-08 PROJECT COMPLETION:** Project final completion shall be defined as "the stage in the progress of the Work where the Work is complete in accordance with the Contract Documents so that the City can begin to utilize the Work for its intended use, all punch list items are complete, and the Contractor has completely demobilized from the project area." Project final completion shall not be more than **210 calendar days**.

**SP-09 LIQUIDATED DAMAGES:** The work shall be completed within the contract time as required by SP-08 "PROJECT COMPLETION." The contract time shall include the preparation, submittal, review and approval of submittals, delivery of materials, and construction, assembly, adjustment and placement into service for beneficial use of all facilities covered under this Contract. The City of North Port shall issue a Notice of Completion when it has determined that the work identified in the contract has been completed per SP-08 "PROJECT COMPLETION."

The City and the Contractor hereby agree that time is of the essence on this Contract and the City will suffer damages if the work is not completed within the contract time as required by SP-07 "Contract Time". It is further recognized and agreed by the City and the Contractor that the determination of the exact value of the damages the City would suffer due to a delay in the Completion of the work would be a difficult, time consuming and costly process. It is therefore hereby agreed by the City and the Contractor that it is in their mutual interest to establish a figure **FOUR HUNDRED AND NINETY-FOUR DOLLARS (\$494.00)** as Liquidated Damages (but not as a penalty) to be paid by the Contractor to the City for each calendar day that Completion is delayed beyond the Contract Time. It is mutually agreed by the City and the Contractor that neither shall make any claim to increase or reduce the amount to be paid under Liquidated Damages as the result of any calculation of actual damages suffered by the City as the result of delay in the Completion of the work.

For all contracts, regardless of whether the contract time is stipulated in calendar days or working days, the City will count default days in calendar days. If the Contractor or, in case of his default, the surety fails to complete the work within the time stipulated in the Contract, or within such extra time that the City may have granted the Contractor or, in case of his default, the surety shall pay to the City, not as a penalty, but as liquidated damages, in the amount of **\$494.00** per calendar day in which work is not completed.

The City has the right to apply, as payment on such liquidated damages, any money the City owes the Contractor.

The City does not waive its right to liquidated damages due under the Contract by allowing the Contractor to continue and finish the work, or any part of it, after the expiration of the Contract Time including granted time extensions.

In the case of default of the Contract and the completion of the work by the City, the Contractor and his surety are liable for the liquidated damages under the Contract, but the City will not charge liquidated damages for any delay in the final completion of the City's performance of the work due to any unreasonable action or delay on the part of

the City.

The City considers the Contract complete when the Contractor has completed all work and the City has accepted the work. The City will then release the Contractor from further obligation except as set forth in his bond.

**SP-10 DAMAGES:** Areas adjacent to the construction that are damaged shall be repaired at the Contractor's expense. Restoration of adjoining areas shall be equal to or better than original condition and to the satisfaction of the City. Protection of personal property, utilities, structures, access drives, conduits, pavement, curbs, sidewalks, trees, and shrubs shall be the responsibility of the Contractor, who shall provide adequate protection to maintain proper service.

**SP-11 CONTINUOUS PROSECUTION OF WORK:** The Contractor shall continuously prosecute the work in accordance with the Contract Documents. Upon written direction from the City, the Contractor shall remove any personnel for the duration of the Contract, who fails to comply with the Contract Documents.

Once commencing the project, the operation must be continuously prosecuted during normal hours to its completion. At no time, shall the Contractor suspend work, for any reason for more than seven (7) calendar days, excluding delays granted for inclement weather. Should the Contractor fail to perform any work on the project for three (3) or more work days, the Contractor shall submit a written request to the City, no less than twenty-four (24) hours in advance of the restart of work, to allow the City to schedule the required inspection personnel. No work may restart, prior to the expiration of the twenty-four (24) hour notice without the City's approval.

Correction of safety concerns will be given priority and shall be corrected as soon as practicable, but not later than 24 hours after discovery by the City and notification to the Contractor. Failure to comply with these Provisions and/or Technical Specifications shall result in the Contractor being considered in default and subject to suspension of this contract.

**SP-12 SAFETY AND PROTECTION:**

- A. Contractor shall be responsible for initiating, maintaining, and supervising all safety precautions and programs in connection with the work. Contractor shall take all necessary precautions for the safety of and shall provide the necessary protection to prevent damage, injury or loss to:
  - i. All employees on the work and other persons or organizations who may be affected thereby.
  - ii. All the work and materials and equipment to be incorporated therein, whether in storage on or off the site.
- B. Other property at the site or adjacent thereto, including trees, shrubs, lawns, walks, pavements, roadways, structures, utilities, and underground facilities not designated for removal, relocation or replacement in the course of construction. Contractor shall comply with all applicable Laws and Regulations of any public body having jurisdiction for the safety of person or property or to protect them from damage, injury or loss; and shall erect and maintain all necessary safeguards for such safety and protection.
- C. All personnel working within the City's right-of-way shall at all times wear City approved safety vests, including personnel who may only briefly be out of their vehicle (i.e., supervisors, truck drivers).
- D. No open excavations are allowed on the project. Any pipe installation shall be backfilled properly the same day of work on such pipe area to allow safe passing of pedestrians and vehicles. The Contractor shall immediately remove any personnel who fail to conform to this requirement.
- E. Contractor shall designate a responsible representative at the site whose duty shall be the prevention of accidents. This person shall be the contractor's superintendent unless otherwise designated in writing by Contractor to City.

**RFB No. 2023-04 RENOVATION OF LIFT STATIONS 29, 45 AND 73**

**SP-13 CHANGES IN THE WORK:** The City, without invalidating the Contract, may order extra work or make changes by altering, adding to or deducting from the work, the Contract sum being adjusted accordingly. Such work will be an **amendment to the contract** and shall require approval by the City Manager prior to prosecution of the additional work. The change and amount of compensation must be agreed upon in writing in a document of equal dignity herewith prior to any deviation from the terms of this Contract. In giving instructions, the City shall have authority to make minor changes in the work, not involving extra cost, and not inconsistent with the purposes of the work. Except in an emergency endangering life or property, no extra work or change shall be made unless in pursuance of a written order by the City; and no claim for an addition to the Contract sum shall be valid, unless ordered.

**Contingency:** An amount added to an estimate to allow for items, conditions, or events for which the state, occurrence, or effect is uncertain and that experience shows will likely result, in aggregate, in additional costs. All contingency items will require approval from the Purchasing Manager or designee, the Finance Director and City Manager prior to any work being performed.

Value of any such extra work or change shall be determined in one or more of the following ways:

1. By estimate and acceptance in a lump sum.
2. By unit prices named in the contract or subsequently agreed upon.
3. By cost and percentage or by cost and a fixed fee.
4. By Change order executed by City Manager
5. By Contingency Authorization (executed by City Manager).

If none of the previous methods are agreed upon, the Contractor, provided he receives an order as above, shall proceed with the work. In such case and also under case, he shall keep amendment in such form as the City may direct, a correct amount of the net cost of labor and materials, together with vouchers. The City shall certify to the amount, including reasonable allowance for overhead and profit, due to the Contractor. Pending final determination of value, no payment on changes shall be made.

**SP-14 SUBCONTRACTING, SUBLETTING AND/OR ASSIGNMENT:** Do not, sell, transfer, assign or otherwise dispose of the Contract or Contracts or any portion thereof, or of the right, title, or interest therein, without written consent of the City. If the Contractor chooses to sublet any portion of the Contract, the Contractor must provide a written request to sublet work to the City for approval. With the City's acceptance of the request, the Contractor may sublet a portion of the work, but shall perform with its own organization work amounting to **not less than 40%** of the total Contract amount. The request will be deemed acceptable by the City, for purposes of the City's consent, unless the City notifies the Contractor within five (5) business days of receipt of the request that the City is not consenting to the requested subletting.

Include in the total Contract amount the cost of materials and manufactured component products, and their transportation to the project site. For the purpose of meeting this requirement the City will not consider off-site commercial production of materials and manufactured component products that the Contractor purchases, or their transportation to the project, as subcontracted work.

If the Contractor sublets a part of a Contract item, the City will use only the sublet proportional cost in determining the percentage of subcontracted normal work. Execute all agreements to sublet work in writing and include all pertinent provisions and requirements of the Contract. All other agreements must be in writing and reference all applicable Contract provisions. Upon request, furnish the City with a copy of the subcontract and agreement. The subletting of work does not relieve the Contractor or the surety of their respective liabilities under the Contract.

The City recognizes a subcontractor only in the capacity of an employee or agent of the Contractor and the Engineer may require the Contractor to remove the subcontractor as in the case of an employee.

## RFB No. 2023-04 RENOVATION OF LIFT STATIONS 29, 45 AND 73

All sublets will be in continued compliance with all Contract provisions and the Contractor will continue to perform the minimum percentage of Contract work with its own organization, as required by said Contract. It is recognized and agreed that the prime contractor remains responsible for the proper performance of all requirements of said contract and use of sublet does not relieve or release the Contractor and his surety or either of them of any liability under the contract bond. A false statement or omission made in connection with subletting is sufficient cause for suspension, revocation, or denial of qualification to bid, and a determination of non-responsibility, and may subject the person and/or entity making the false statement to any and all civil and criminal penalties available pursuant to applicable Federal and State Law.

**SP-15 AVAILABILITY OF LANDS:** Work is planned to occur within rights of way or existing utility easements. The Contractor will be held responsible to obtain right of way use permit(s) from the City of North Port. NPU will pay the permit fee directly to the Neighborhood Development Services Department. Any additional or repeat inspection or testing charges shall be paid by the Contractor. See Special Provision SP-17.

**SP-16 COORDINATION OF THE SPECIFICATIONS:** Where conflicts between the City of North Port General Provisions, Special Provisions, Technical Specifications and Construction Plans, references, should they exist, it is the responsibility of the bidding Contractor to bring those conflicts to the attention of the Purchasing Agent prior to the bid date. After bids, have been received, the contractor will be held to the most stringent requirement.

The Contractor shall take no advantage of any apparent error or omission in the plans or specifications. If the Contractor discovers such an error or omission, he shall immediately notify the City. The City will then make such corrections and interpretations as may be deemed necessary for fulfilling the intent of the plans and specifications.

**SP-17 CONSTRUCTION PERMITS:** Florida Department of Environmental Protection/Department of Health permits are not required for this work.

The City will pay for all permit fees determined by the Neighborhood Development Services Department and the City of North Port Public Works Department. For this project, Right of Way (ROW) permit(s) will not be required. The City will make payment directly to the Neighborhood Development Services Department for any miscellaneous fees assessed for the necessary permits and related inspections. Additional or re-inspection fees shall be paid for by the Contractor. Pressure testing the system, if required, shall be paid for by the Contractor. Permits and licenses necessary for the prosecution of the work shall be secured by the Contractor.

**SP-18 NOTICE-OF-INTENT (NOI):** If necessary, the Contractor for the project shall submit a Notice of Intent to Use Generic Permit for Stormwater Discharge from Large and Small Construction Activities, along with the permit fee with the Florida Department of Environmental Protection.

**SP-19 SPECIFICATIONS AND PLANS:** Information regarding this project may be viewed and downloaded from DemandStar's website at [www.demandstar.com](http://www.demandstar.com). Links to DemandStar are also available from the city website at [www.cityofnorthport.com](http://www.cityofnorthport.com). Bid documents are posted on the City FTP site at <https://www.cityofnorth.com/filesshare>.

**SP-20 CONTRACTOR'S UNDERSTANDING:** It is understood and agreed that the Contractor has, by careful examination, satisfied himself as to the nature and locations of the work, the conformation of the ground, the character, quality, and quantity of materials to be encountered, the character of equipment and facilities needed prior to and during prosecution of the work under this Contract. No verbal agreement or conversation with any officer, agent, or employee of the City, either before or after execution of this Contract, shall affect or modify the terms or obligations herein contained.

**RFB No. 2023-04 RENOVATION OF LIFT STATIONS 29, 45 AND 73**

**SP-21 ERRORS OR OMISSIONS IN PERMITS, PLANS OR SPECIFICATIONS:** The Bidder shall take no advantage of any apparent error or omission, which may be discovered in the Permits, Plans or Specifications but shall forthwith notify the City Representative of such discovery, who will then make such correction and interpretations as deemed necessary for reflecting the actual spirit and intent of the Permits and Specifications.

**SP-22 ROAD/LANE CLOSURE:** No road closures are allowed. A lane closure request must be submitted in writing five (5) business days in advance of the requested lane closure. The time and length of closure(s) shall be approved by the City of North Port. The Contractor shall provide a Maintenance of Traffic (MOT) Plan for the requested lane closure(s) for review and approval by the City of North Port.

**SP-23 MAINTENANCE OF TRAFFIC:** The contractor shall be responsible for all maintenance of traffic and obtaining approval of a Maintenance of Traffic (MOT) Plan from the City for work within the ROW of any City Road. The Contractor shall maintain traffic at all times during construction.

**SP-24 DEWATERING:** The Contractor shall request approval from the City of North Port Project Manager before applying for a permit from the Southwest Florida Water Management District.

**SP-25 PRIVATE PROPERTY:** The Contractor shall not occupy private land outside of any easements or rights of way unless a written authorization has been signed by the property owner. It shall be the Contractor's responsibility to obtain these agreements prior to construction, if required. Prior to the use of private lands, the Contractor shall submit a copy of the agreement(s) to the City. In the event that the Contractor uses private property for any purpose without first having obtained the necessary approvals from the property owner or provided the necessary agreement to the City, the City will direct the Contractor in writing to immediately cease using such property.

Prior to application for final payment, the Contractor shall provide documentation from the owner of each piece of private property for which an agreement for use was provided, or for which the City has issued written notification to the Contractor, that each owner is satisfied with the manner in which the Contractor has restored the property. Final payment or reduction in retainage shall not be paid until such documentation is received by the City.

Any areas, outside of the rights-of-way or easements that are impacted or damaged by the Contractor's activities shall be repaired at the Contractor's expense to the property owner's satisfaction. Restoration of impacted areas shall be equal to or better than original condition and to the satisfaction of the property owner. The Contractor shall be responsible to secure written approval of the restoration of the property from the property owner and submitting a copy to the City prior to requesting Substantial Completion. The City shall not release retainage to the Contractor until such time as the approvals are submitted by the Contractor.

**SP-26 RESIDENTS CONCERNS:** During the work of this Contract, residents may contact the City to question the progress of the work or express concerns regarding the work. These concerns are responded by City's Utilities Department, but normally the Contractor will have more detailed information on the actual scheduling of the work or corrective measures required. Therefore, the Contractor will provide a telephone number and email address where City's Utilities Department can fax or email inquiries. The Contractor shall respond to these inquiries within two (2) business days detailing how the inquiry will be addressed and the time frame the Contractor will take in addressing this inquiry. City's Utilities Department will maintain a log of inquiries, which will be reviewed at each progress meeting.

**SP-27 TESTING:** Any and all testing requirements born out of, but not limited to contract requirements and permits, for the installation of utility piping, including but not limited to, pressure testing, will be included in the Contractor's bid price. Testing shall include all utilities installed as part of the work of these Contract Documents. Testing will be arranged in advance with an independent testing firm (also included in the bid price) for the testing of concrete and compaction. The City requests to be notified three (3) business days in advance of any test in order to have a City

## RFB No. 2023-04 RENOVATION OF LIFT STATIONS 29, 45 AND 73

representative and the Engineer of Record, if required, present. Where less time for notice is specified in the specifications or plans, this special provision shall prevail.

**SP-28 MISCELLANEOUS ITEMS:** Miscellaneous items and accessories which are not specifically mentioned, but which are essential to produce a complete and properly operating installation, or usable structure or plant, providing the indicated function, shall be furnished and installed without change in the Contract Price. Such miscellaneous items and accessories shall be of the same quality standards, including material, style, finish, strength, class, weight and other applicable characteristics, as specified for the major component of which the miscellaneous items or accessory is an essential part, and shall be approved by the City's Engineer of Record before installation. The above requirement is not intended to include major components not covered by or inferable from the Drawings and Specifications.

**SP-29 SOURCES OF WATER FOR TESTING, CLEANING, AND OTHER CONSTRUCTION PURPOSES:** Reclaimed water piping pressure and flow testing and flushing may be done with reclaimed water. All Contractors' connection(s) to the City reclaimed water supply shall allow the City to meter the amount of reclaimed water used in testing, flushing, and other miscellaneous purposes during construction, etc. The Contractor is responsible for obtaining meter(s) and associated appurtenances, and paying all appropriate fees/deposits. Contractor shall not use any water until meter is installed. The actual reclaimed water used will be provided at no cost to the Contractor by Utilities. Any fees/deposits due back to the Contractor will be returned after the project is completed and the meter is removed.

If potable water is required for the Work of this Contract, all Contractors' connection(s) to the City potable water supply shall allow the City to meter the amount of water used. All potable water connections shall include a reduced pressure zone backflow preventer. The Contractor is responsible for obtaining meter(s), backflow preventers, and associated appurtenances, and paying all appropriate fees/deposits. Contractor shall not use any potable water until meter and backflow preventer are installed. The Contractor will set up an account with the City and will be billed at the City's normal rates for actual potable water used. Any fees/deposits due back to the Contractor will be returned after the project is completed and the meter is removed.

**SP-30 POTABLE WATER AND WASTEWATER FORCE MAIN OVER-DEPTH AND PLACEMENT:** Potable water mains and wastewater force mains shall be installed with a minimum of thirty-six (36") inches of cover over the pipe. Any required over-depth, whether shown on the plans or not, will be considered to be incidental to the main installation and no additional compensation will be made therefore.

**SP-31 PRE-INSTALLATION VIDEO:** No construction shall take place prior to the City's acceptance of the Pre-Installation Video. The video shall thoroughly capture the intended work area as outlined in the Contract Documents. The Pre-Installation Video will be used to protect all parties involved in the project.

**SP-32 PERIODIC CLEAN UP AND RESTORATION:** During construction, the Contractor shall regularly remove from site and properly dispose of all accumulated debris and surplus material of any kind that result from their operations. The Contractor shall remove unsightly mounds of earth, large stones, boulders, and debris so the site presents a neat appearance. Burial of construction debris is not permitted. Unused tools and equipment shall be stored at the Contractor's yard or base of operations for the project. When the contract work involves ROWs, private property, roadways, private driveways or access roads, easements and sidewalks, and any site work that may impede pedestrian or vehicular traffic while the installation work is in progress, the Contractor shall backfill, grade, compact, and otherwise restore the area to the basic condition which existed prior to work in order to allow vehicular and pedestrian use. All areas should be restored to their original design grade to facilitate drainage.

**SP-33 CONNECTION TO EXISTING POTABLE WATER AND WASTEWATER FORCE MAIN(S):** The connections to the existing potable water and wastewater force mains shall be paid at the contract bid price per each which shall include the cost of connection, satisfactory coordination of utility construction, labor, material, equipment and all other associated appurtenances required to complete the project in accordance with the Contract Documents. Tie-ins to

**RFB No. 2023-04 RENOVATION OF LIFT STATIONS 29, 45 AND 73**

existing main(s) shall be coordinated with City Utilities.

It shall be the express responsibility of the Contractor to connect his Work to each part of the existing work or of work previously installed as required by the Drawings and Specifications to provide a complete installation.

Connections/modifications to existing piping requires coordination with City Utilities staff. The Contractor shall not operate any existing valves.

**SP-34 MAINTENANCE OF FLOW:** It is the Contractor's responsibility to maintain the flow of the existing potable water, wastewater force mains, and lift stations during the construction. Maintenance of flow is considered incidental to the work and shall be done at no additional cost to the City.

**SP-35 CITY RIGHT-OF-WAY RESTORATION:** The ROW restoration includes all procedures to restore the ROW to a condition equal to or better than the original condition to the satisfaction of the City. The Contractor shall be responsible for restoration of items including but not limited to existing structures, stabilized roads, and ground areas damaged during construction.

During installation of new utilities, the Contractor shall maintain, an undisturbed existing buffer strip of ground cover measuring a minimum of one foot (1') in width from the edge-of- pavement (EOP) in order to minimize potential erosion along the pavement edge. The Contractor shall be responsible for all costs to restore this buffer strip if disturbed during construction.

**SP-36 LABOR, MATERIALS AND EQUIPMENT:** The Contractor will provide competent, suitably qualified personnel to survey and lay out the Work and perform construction as required by the Contract Documents. He will at all times maintain good discipline and order at the site.

The Contractor will furnish all materials, equipment, labor, transportation, construction equipment and machinery, tools, appliances, fuel, power, light, heat, local telephone, water and sanitary facilities and all other facilities and incidentals necessary for the execution, testing, initial operation and completion of the Work.

All materials and equipment will be new, except as otherwise provided in the Contract Documents. When special makes or grades of material which are normally packaged by the supplier or manufacturer are specified or approved, such materials shall be delivered to the site in their original packages or container with seals unbroken and labels intact.

All materials and equipment shall be applied, installed, connected, erected, used, cleaned and conditioned in accordance with the instructions of the applicable manufacturer, fabricator or processors, except as otherwise provided in the Contract Documents.

**SP-37 MATERIALS, EQUIPMENT, PRODUCTS, AND SUBSTITUTIONS:** Materials, equipment and products incorporated in the Work must be approved for use before being purchased by the Contractor. The Contractor shall submit to the City a list of proposed materials, equipment or products, together with such samples as may be necessary of him to determine their acceptability and obtain his approval. No request for payment for "or equal" equipment will be approved until this list has been received and approved by the City.

Whenever a material, article or piece of equipment is identified on the Drawings or Specifications by reference to brand name or catalog number, it shall be understood that this is referenced for the purpose of defining the performance or other salient requirements and that other products of equal capacities, quality and function shall be considered per 40 CFR 33.255(c) as referenced in Chapter 62-552, FAC. The Contractor may recommend the substitution of a material,



## RFB No. 2023-04 RENOVATION OF LIFT STATIONS 29, 45 AND 73

article, or piece of equipment of equal substance and function for those referred to in the Contract Documents be reference to brand name or catalog number, and if, in the opinion of the City, such material, article, or piece of equipment is of equal substance and function to that specified, the City may approve its substitution and use by the Contractor. Incidental changes or extra component parts required to accommodate the substitute will be made by the Contractor without a change in the Contract Price or Contract Time.

No substitute shall be ordered or installed without the written approval of the City who shall be the judge of equality. Delay caused by obtaining approvals for substitute materials will not be considered justifiable grounds for an extension of construction time.

Should any work or materials, equipment or products not conform with requirements of the Drawings and Specifications or become damaged during the progress of the Work, such Work or materials shall be removed and replaced, together with any work disarranged by such alteration, at any time before completion and acceptance of the Project. All such work shall be done at the expense of the Contractor.

No materials or supplies for the Work shall be purchased by the Contractor or by any Subcontractor subject to any chattel mortgage or under a conditional sale or other agreement by which an interest is retained by the Seller. The Contractor warrants that he has good title to all materials and supplies used by him in the Work.

**SP-38 USE OF PREMISES:** The Contractor shall confine his apparatus, storage of materials, and operations of his workmen to limits indicated by law, ordinances, permits, and directions of City, and shall not unnecessarily encumber any part of the site.

Contractor shall not overload or permit any part of any structure to be loaded with such weight as will endanger its safety, nor shall he subject any part of the Work to stresses or pressures that will endanger it.

Contractor shall enforce City's instructions in connection with signs, advertisements, fires and smoking.

Contractor shall arrange and cooperate with City in routing and parking of automobiles of his employees, Subcontractors and other personnel, and in routing material delivery truck and other vehicles to the Project site.

**SP-39 SURVEY:** All survey monuments and benchmarks that may be disturbed during construction shall be referenced and replaced by the Contractor. All monuments and benchmarks disturbed or destroyed by the Contractor or any of his forces through accident or negligence shall be replaced by a Florida Licensed Professional Land Surveyor at the Contractor's expense.

**SP-40 MANUFACTURER'S LITERATURE:** Manufacturer's literature, when referenced, shall be dated and numbered and is intended to establish the minimum requirements acceptable. Whenever reference is given to codes, or standard specifications or other data published by regulating agencies or accepted organizations, including but not limited to National Electrical Code, applicable State Building Code, Federal Specifications, ASTM Specifications, various institute specifications, and the like, it shall be understood that such reference is to the latest edition including addenda in effect on the date of Bid.

**SP-41 BRAND NAMES:** Brand names where used in the technical specifications, are intended to denote the standard of quality and performance required of the particular material or product. The term "equal" or "equivalent", when used in connection with brand names, shall be interpreted to mean a material or product that is similar and equal in type, quality, size, capacity, composition, finish, color and other applicable characteristics to the material or product specified by trade name, and that is suitable for the same use and capable of performing the same function, in the opinion of the City's Engineer of Record, as the material or product so specified. The City's Engineer of Record must approve proposed equal items before they are purchased or incorporated in the Work.

**RFB No. 2023-04 RENOVATION OF LIFT STATIONS 29, 45 AND 73**

**SP-42 RECORD DRAWINGS:** The Contractor will keep one record copy of all Specifications, Drawings, Addenda, Modifications, and Shop Drawings at the site in good order and annotated to show all changes made during the construction process. Record Drawings shall list all equipment removed from existing facilities. These shall be available to the City, City's Representative, City's Engineer of Record, and to the State of Florida Department of Environmental Protection (FDEP), and shall be delivered by him to the City upon completion of the Project. It shall be used for this purpose only. Final payment will not be made until receipt and approval by the City of Record Drawings.

**SP-43 RECORD DRAWINGS CERTIFICATION:** The certification statement shall be as follows:

"I hereby certify that the as-built location information of the water and wastewater facilities shown on these drawings conforms to the Minimum Technical Standards for Land Surveying in the State of Florida, chapter 5J-17.052 (Florida Administrative Code), as adopted by the Department of Agriculture and Consumer Services, Division of Consumer Services, Board of Professional Surveyors and Mappers in 2010, and that said as-builts are true and correct to the best of my knowledge and belief as surveyed under my direction."

**SP-44 COMPLETION OF THE PROJECT:** The Completion of the project shall be accomplished and finalized prior to submittal of the application for final payment by the Contractor. The City shall determine the date of completion for the project when at the minimum, the following are met as well as all other conditions defined in the Contract Documents:

- All punch list items have been addressed to the satisfaction of the City;
- All testing has been completed and results are satisfactory (including but not limited to Pipe Pressure Test, Concrete, and Compaction Tests);
- Record Drawing requirements have been accepted and approved by the City and all other governmental agencies, if applicable;
- All associated equipment and facilities necessary for the reliable operation of the project are complete in accordance with contract requirements; and,
- All release of liens have been submitted and are satisfactory to the City, certifying that all payrolls, material bills, and other indebtedness incurred by the Contractor in connection with this project have been paid in full.

**SP-45 STORED MATERIALS:** Payment for stored materials will made in accordance with Section 3.2 of the General Provisions.

**SP-46 PAYMENT ADJUSTMENT:** The following will apply: This Contract will *not* provide for fuel or other payment adjustments due to increase in material costs during the life of the contract.

**SP-47 TERMINOLOGY:** Throughout the Contract Documents, references to City or Owner shall, where appropriate, refer to the City of North Port, a municipal corporation of the State of Florida. References to Utilities Department and North Port Utilities refer to the City of North Port's Utilities Department and are used interchangeably. References to Engineer or "Resident Project Representative" may, where appropriate, refer to either the City's Engineer of Record for the Project, which is CDM Smith, or to the City's Utilities Engineering Manager.

The terms General Conditions and General Provisions are used interchangeably in the Contract Documents. The terms Special Conditions and Special Provisions are used interchangeably in the Contract Documents.

The term "Contract Documents" is used interchangeably with "Agreement."

**SP-48 WORK HOURS:** The Contractor shall conduct work between 7 A.M. and 3:30 P.M. Monday through Friday, which is defined as regular work hours. The Contractor shall not conduct work on Saturdays, Sundays, legal holidays or

**RFB No. 2023-04 RENOVATION OF LIFT STATIONS 29, 45 AND 73**

holidays observed by the City. Work conducted outside of the regular work hours and days shall be permitted only with written permission from the City. Any additional cost incurred by North Port Utilities and/or the Engineer of Record for work outside these hours will be paid by the Contractor.

**SP-49 NOTIFICATIONS OF 48 HOURS:** Wherever the technical specifications or plans indicate a minimum of 48 hours' notice to Owner/City or Engineer, this special provision shall prevail dictating a minimum of three (3) business days' notice to Owner/City or Engineer.

**SP-50 QUALIFICATIONS/REFERENCES:** Contractor shall submit a minimum of four (4) recent (within the past five (5) years) references of projects of similar size and scope involving renovation and rehabilitation of lift station services being offered to the City. Each reference shall include a project description, project location, name and phone number of a contact person, total project amount, and completion date.

The City reserves the right to contact references. Bidder is referred to MINIMUM QUALIFICATIONS AND REFERENCE FORM included later herein. Please provide accurate telephone and e-mail address for contact person.

**SP-51 LICENSE(S) REQUIREMENT:** Certified General Contractor OR Certified Underground Utilities Contractor.

**SP-52 CITY'S STATUS:** The City shall examine and inspect the work to assure compliance with the requirements of these Contract Documents. The City shall determine the quality and acceptability of materials and workmanship relative to the requirements of the Plans and Technical Specifications. The City has the authority as follows:

1. To stop the work whenever such stoppage may be necessary to insure the proper execution of the Contract.
2. To reject all work which does not conform to the Contract.
3. To resolve questions which arise in the execution of the work.
4. To stop work whenever materials or shop drawings have not been approved prior to placement.

No additional time or compensation will be added to the Contract when stopping the work for the above listed reasons.

**SP-53 CRITERIA FOR AWARD:** The award of this bid shall be to the lowest responsive, responsible bidder in whole or in part whichever is determined to be in the best interest of the City, meeting the requirements of the specifications, grant requirements and provisions set forth herein. Any unfavorable references may be cause to deem bidder non-responsive.

The City reserves the right to reject the bid proposal of any bidder who has previously failed to perform properly, or on time, contracts of similar nature; or who is not in a position to satisfactorily perform the contract.

**END OF SECTION III**

**SPECIAL CONDITIONS FOR CDBG CONTRACTS**

**A. Remedies for Violation or Breach of Contract Terms**

All claims, disputes and other matters in question between the parties to this agreement, arising out of or relating to this agreement or the breach thereof, shall be resolved as provided as follows:

1. To the extent Chapter 558, F.S. is applicable, the parties expressly opt out of the requirements of Chapter 558, F.S., within the mean of §558.005(1), F.S.
2. In the event of a dispute or claim arising out of this Agreement, the parties agree first to try in good faith to settle the dispute by direct discussion. If this is unsuccessful, the parties may enter into mediation in Sarasota County, Florida, with the parties sharing equally in the cost of such mediation.
3. In the event mediation, if attempted, is unsuccessful in resolving a dispute, the parties may proceed to litigation as set for the below.
4. Any dispute, action or proceeding arising out of or related to this Agreement will be exclusively commenced in the state courts of Sarasota County, Florida, or where subject matter jurisdiction exists in the United States District Court for the Middle District of Florida. Each party irrevocably submits and waives any objections to the exclusive personal jurisdiction and venue of such courts, including any objection based on forum non conveniens.
5. The parties agree to waive all rights to trial by jury for any litigation undertaken concerning this Agreement.
6. This Agreement and the rights and obligations of the parties shall be governed by the laws of the State of Florida without regard to its conflict of laws principles.
7. Unless otherwise agreed in writing, the Consultant shall be required to continue its services and all other obligations under this Agreement during the pendency of claim or dispute including, but not limited to, actual period of mediation or judicial proceedings.

**(All contracts over \$150,000)**

**B. Patent and Copyrights**

The U.S. Department of Housing and Urban Development (HUD) and Sarasota County retain patent rights and copyrights on any project which involves research, developmental, experimental, or demonstration work. **(All contracts)**

**C. Adherence to State Energy Conservation Plan**

The successful bidder shall recognize and adhere to mandatory standards and policies relating to energy efficiency which are contained in the State energy conservation plan issued in compliance with Energy Policy and Conservation Act (Public Law 94-163). **(All contracts)**

#### **D. Access to Records**

Sarasota County, the consultant operating on behalf of Sarasota County, the State of Florida, the U.S. Department of HUD, the Comptroller General of the United States, or any of their authorized representatives, shall have access to any books, documents, papers, and records of the contractor which are directly pertinent to this contract, for the purpose of performing audit or project monitoring, and such records shall be subject to examination, copying, excerpting or transcribing.

**(All contracts)**

#### **E. Records Retention**

In general, records are to be retained for 4 years from the date of submission of the grantee's fiscal year-end report in which the specific activity is reported for the last time, unless there is litigation, claims, audit, negotiation, or other actions involving the records, which has started before expiration of the 4-year period. In such cases, the records must be retained until completion of the action and resolution of all issues which arise from it or the end of the regular 4-year period, whichever is longer. **(All contracts)**

#### **F. Equal Employment Opportunity**

Except as otherwise provided under 41 CFR Part 60, for all contracts that meet the definition of "federally assisted construction contract" in 41 CFR Part 60-1.3, the contractor is required to comply with 41 CFR Part 60-1.4(b), EO 11246, "Equal Employment Opportunity," (30 FR 12319, 12935, 3 CFR Part, 1964-1965 Comp., P339) as amended by E.O. 11375, "Amending Executive Order 11246 Relating to Equal Employment Opportunity", and implementing regulations at 41 CFR Part 60 "Office of Federal Contract Compliance Programs, Equal Employment Opportunity, Department of Labor". The Contractor is required to include this in all subcontracts involving federally assisted construction contracts. **(All contracts)**

#### **G. Federal Equal Opportunity Laws**

1. Certification of Non-segregated Facilities (for contracts over \$10,000)
2. Title VI, Civil Rights Act of 1964
3. Section 109 of the Housing & Community Development Act of 1974
4. Section 503 Handicapped (for contracts \$2,500 or over)
5. Age Discrimination Act of 1975
6. Section 504 of the Rehabilitation Act of 1973

#### **H. Rights to Inventions Made Under a Contract**

Contractor shall comply with 37 CFR Part 401, "Rights to Inventions Made by Nonprofit Organizations and Small Business Firms Under Government Grants, Contracts and Cooperative Agreements", and any implementing regulations issued by HUD. **(All contracts)**

#### **I. Procurement of Recovered Material**

A non-federal entity that is a state agency or agency of a political subdivision of a state and its contractors must comply with section 6002 of the Solid Waste Disposal Act, as amended by the

## RFB No. 2023-04 RENOVATION OF LIFT STATIONS 29, 45 AND 73

Resource Conservation and Recovery Act. The requirements of Section 6002 include procuring only items designated in guidelines of the Environmental Protection Agency (EPA) at 40 CFR part 247 that contain the highest percentage of recovered materials practicable, consistent with maintaining a satisfactory level of competition, where the purchase price of the item exceeds \$10,000 or the value of the quantity acquired during the preceding fiscal year exceeded \$10,000; procuring solid waste management services in a manner that maximizes energy and resource recovery; and establishing an affirmative procurement program for procurement of recovered materials identified in the EPA guidelines. **(All contracts over \$10,000)**

### **J. Byrd Anti-Lobbying Amendment (31 U.S.C. 1352)**

Contractor is required to file the required certification for Bids over \$100,000.00. Each tier certifies to the tier above that it will not and has not used Federal appropriated funds to pay any person or organization for influencing or attempting to influence an officer or employee of any agency, a member of Congress, officer or employee of Congress, or an employee of a member of Congress in connection with obtaining any Federal Contract, grant or other award covered by 31 U.S.C. 1352. Each tier shall also disclose any lobbying with non-Federal funds that takes place in connection obtaining any Federal award. **(All contracts over \$100,000)**

### **K. Data Universal Numberings**

All contractors participating in this project must have a Data Universal Numbering System (DUNS) number and be registered on the federal System for Award Management (SAM) at sam.gov. **(All contracts)**

### **L. Debarment and Suspension**

A contract award (see 2 CFR 180.220) must not be made to parties listed on the governmentwide Excluded Parties List System in the System for Award Management (SAM), in accordance with the OMB guidelines at 2 CFR 180 that implement Executive Orders 12549 (3 CFR Part 1986 Comp., p. 189) and 12689 (3 CFR Part 1989 Comp., p. 235), "Debarment and Suspension." The Excluded Parties List System in SAM contains the names of parties debarred, suspended, or otherwise excluded by agencies, as well as parties declared ineligible under statutory or regulatory authority other than Executive Order 12549. **(All contracts)**

### **M. Restriction on all Public Works Projects**

No contractor, or subcontractor, of a foreign country included on the list of countries that discriminate against U.S. firms published by the Office of the United States Trade Representative (USTR) may be awarded a contract or a subcontract for public works projects. Nor may any product of a country included on this list be provided under a public works project. Any offerer unable to certify compliance with this provision shall submit with its offer a written explanation fully describing the reasons for its inability to comply. **(All contracts)**

### **N. Drug-Free Workplace Requirements**

The Drug-Free Workplace Act of 1988 (42 U.S.C. 701) requires grantees (including individuals) of federal agencies, as a prior condition of being awarded a grant, to certify that they will provide drug-free workplaces. Contractor is required to comply with drug-free workplace requirements in accordance with the Act and with HUD rules at 24 CFR Part 24, Sub-Part F. **(All contracts)**

### **O. Clean Air and Water Act**

## RFB No. 2023-04 RENOVATION OF LIFT STATIONS 29, 45 AND 73

The contract must comply with all applicable standards, orders, or requirements issued under the Clean Air Act (42 U.S.C. 7401-7671q.) and the Federal Water Pollution Control Act (33 U.S.C. 1251-1387), as amended. Violations must be reported to the Federal awarding agency and the Regional office of the Environmental Protection Agency (EPA). **(All contracts over \$150,000)**

### P. Davis-Bacon Requirements

The contractor shall comply with the Davis-Bacon Act, as amended (40 USC 3141-3148) as supplemented by Department of Labor regulations (29 CFR, Part 5). Under this Act contractors shall be required to pay wages to laborers and mechanics at a rate not less than the minimum wages specified in a wage determination made by the Secretary of Labor. In addition, contractors shall be required to pay wages not less often than once a week. A copy of the prevailing wage rates is included in this solicitation. Any known changes to these wage rates prior to award of contract, shall be made known to offerers. In addition, contractors will be required to provide payroll information to Sarasota County on a weekly basis for verification of compliance. Sarasota County shall report all suspected or reported violations of this condition to the U.S. Department of Housing and Urban Development and/or the U.S. Department of Labor. **(All construction contracts over \$2,000)**

### Q. Copeland "Anti-Kickback Act"

The contractor shall comply with the Copeland "Anti-Kickback" Act (40 USC 3145) as supplemented in Department of Labor regulations (29 CFR, Part 3). This Act provides that each contractor or subgrantee shall be prohibited from inducing, by any means, any person employed in the construction, completion, or repair of public work, to give up any part of the compensation to which he is otherwise entitled. Sarasota County shall report all suspected or reported violations to the U.S. Dept. of Housing and Urban Development. **(All construction contracts over \$2,000)**

### R. Contract Work Hours and Safety Standards

The contractor shall comply with 40 USC 3702 and 3704 of the Contract Work Hours and Safety Standards Act as supplemented by Department of Labor regulations (29 CFR, Part 5). Under 40 USC 3702 of the Act, each contractor shall be required to compute the wages of every mechanic and laborer on the basis of a standard workweek of forty (40) hours. Work in excess of that standard work week is permissible provided that the worker is compensated at a rate of not less than one and half times (1.5) the basic rate of pay for all hours worked in excess of forty (40) hours in the work week. (This requirement applies to time spent on federally assisted contracts only.) The requirements of 40 USC 3704 are applicable to construction work and provide that no laborer or mechanic must be required to work in surroundings or under working conditions which are unsanitary, hazardous, or dangerous. These requirements not apply to the purchases of supplies or materials or articles ordinarily available on the open mark, or contracts for transportation or transmission of intelligence. **(All contracts over \$100,000)**

### S. Section 3

Section 3 –According to 24 CFR §75.3(a)(2) a Section 3 project is the site or sites together with any building(s) and improvements located on the site(s) that are under common ownership, management and financing. (This clause is applicable only if the Community Development Block Grant funding exceeds \$200,000, and the funded activity leads to construction i.e. engineering, program management etc.)

### Opportunities:

**RFB No. 2023-04 RENOVATION OF LIFT STATIONS 29, 45 AND 73**

1. The work to be performed under this contract is subject to the requirements of Section 3 of the Housing and Urban Development Act of 1968, as amended, 12 U.S.C. 1701u (Section 3). The purpose of Section 3 is to ensure employment and other economic opportunities to the greatest extent feasible to low- and very-low income persons and businesses.

2. The parties to this contract agree to comply with HUD's regulations in 24 CFR §75, which implement Section 3. As evidenced by their execution of this contract, the parties to this contract certify that they are under no contractual or other impediment that would prevent them from complying with the part 75 regulations. To the greatest extent feasible, the Prime Contractor should encourage Section 3 Workers or Business Concerns to participate in the project.

3. According to §75.5 the Section 3 Targeted Worker is a low- or very-low income worker residing within the neighborhood or service area of the project, and a 'Section 3 Worker' is any worker who currently fits or when hired within the past five years (since 11-30-2020) fit at least one of the following criteria:

- Low- or very low-income, as established by HUD's income limits;
- Employed by a Section 3 business concern; or
- A Youth Build participant.

Documentation must be maintained to ensure workers meet the definitions. Requirements for a Section 3 Worker may include:

- Worker's self-certification that their income is below the income limit from the prior calendar year;
- Worker's self-certification of participation in a means-tested program such as Public Housing or Section 8;
- Certification from a Public Housing Authority (PHA) or Section 8 program manager that the worker is a participant in such a program;
- Employer's certification that the worker's income from that employer is below the income limit; or
- Employer's certification that the worker is employed by a Section 3 Business Concern.

Requirements for a Targeted Section 3 Worker may include:

- Worker's self-certification of participation in a means tested program such as Public Housing or Section 8;
- Certification from a PHA or Section program manager that the worker is a participant in such a program;
- Employer's certification that the worker is employed by a Section 3 Business Concern; or
- Worker's certification that the worker is a Youth Build participant.

4. According to §75.5 businesses that meet one of the following criteria within the last six (6) months are considered Section 3 Business Concerns:

- At least 51% owned and controlled by low-income or very low-income persons;
- Over 75% of labor hours performed for the business over prior 3-month period are performed by Section 3 Workers;
- At least 51% owned and controlled by current residents of public housing or Section 8 assisted housing; and
- Businesses must verify their status as a Section 3 business concern at the time the contract is awarded.

5. Qualitative reporting based upon §75.25(b) would include a description of efforts taken to meet requirements for Section 3 Workers or Business Concerns. Examples include:

- Holding Job Fairs;
- Conduct On-Job Training; or
- Outreach Efforts to Public Housing Residents.



Section 3 is race and gender neutral. If a business qualifies as a Section 3 Business, the business owner(s) are encouraged to register as such on HUD's Section 3 Registry which can be found at:

<https://portalapps.hud.gov/Sec3BusReg/BRegistry/BRegistryHome>

**(Contracts Greater Than \$200,000)**

**N. Termination**

All contracts in excess of \$10,000 must address termination for cause and for convenience by the non-Federal entity including the manner by which it will be effected and the basis for settlement, as found in RFB 2023-04

**(All contracts over \$10,000)**

**O. Bonding**

Contractor must meet the following minimum requirements:

(1) A bid guarantee from each bidder equivalent to five percent of the bid price. The "bid guarantee" must consist of a firm commitment such as a bid bond, certified check, or other negotiable instrument accompanying a bid as assurance that the bidder will, upon acceptance of the bid, execute such contractual documents as may be required within the time specified.

(2) A performance bond on the part of the contractor for 100 percent of the contract price. A "performance bond" is one executed in connection with a contract to secure fulfillment of all the contractor's obligations under such contract.

(3) A payment bond on the part of the contractor for 100 percent of the contract price. A "payment bond" is one executed in connection with a contract to assure payment as required by law of all persons supplying labor and material in the execution of the work provided for in the contract. **(All contracts over \$150,000)**

**V. Insurance**

The following insurance items are required, as found in RFB 2023-04

**End of Special Provisions**

**END OF SECTION IV**

**BIDDER CHECKLIST (INCLUDE THIS LIST W/SUBMITTAL)**

p 44

- ATTACHMENTS TO BE COMPLETED AND RETURNED WITH BID**

**SEALED RFB ENVELOPE LABEL**

p 45

**Check (v)**

**ATTACHMENT 1:** Insurance Requirements and Acknowledgement (**page 51 acknowledgement to be submitted**)

**ATTACHMENT 2:** Excel Tabulation Price Sheet (**must complete and Submit in excel format on USB DRIVE**). **DO NOT RECREATE THIS FORM.**

**ATTACHMENT 3:** Bid Form

**ATTACHMENT 4:** Statement of Organization

**ATTACHMENT 5:** Addenda and Bond Form

**ATTACHMENT 6:** Equipment and Source of Supply/Subcontractor List

**ATTACHMENT 7:** Qualifications and References

**ATTACHMENT 8:** Non-Collusive Affidavit

**ATTACHMENT 9:** Conflict of Interest

**ATTACHMENT 10:** Public Entity Crime Information

**ATTACHMENT 11:** Drug-Free Workplace Form

**ATTACHMENT 12:** Not Applicable

**ATTACHMENT 13:** Sworn Statement: The Florida Trench Safety Act

**ATTACHMENT 14:** Scrutinized Company Certification Form

**ATTACHMENT 15:** Lobbying Certification

**ATTACHMENT 16:** Vendor's Certification For E-Verify System

**ATTACHMENT 17:** Bind Bond (Must use this form and attach with Bid submittal)

**ATTACHMENT 18:** Performance and Payment Bond (**AWARDED VENDOR MUST USE THIS FORM**)

**"SAMPLE" RFB CONTRACT – SUBJECT TO CHANGE**

\_\_\_\_\_  
\_\_\_\_\_  
\_\_\_\_\_  
\_\_\_\_\_  
\_\_\_\_\_  
\_\_\_\_\_  
\_\_\_\_\_  
\_\_\_\_\_  
\_\_\_\_\_  
\_\_\_\_\_  
\_\_\_\_\_  
\_\_\_\_\_  
\_\_\_\_\_  
\_\_\_\_\_  
\_\_\_\_\_  
**AWARDED VENDOR  
DO NOT SUBMIT**

**ENVELOPES MUST BE MARKED**

**"SEALED BID ENVELOPE LABEL BELOW (NEXT PAGE)".**

**PLEASE NOTE: Courier Packages (Fedex, UPS, etc.) shall be clearly marked.**

**If not using label provided on the next page, please include the following on the outside envelope: COMPANY NAME, RFB #, RFB TITLE, DATE DUE, TIME DUE, SUBMITTED BY, NAME OF COMPANY, E-MAIL ADDRESS, TELEPHONE.**

Date: \_\_\_\_\_

Signed (*Person authorized to bind the company*): \_\_\_\_\_

Name (printed): \_\_\_\_\_ Title: \_\_\_\_\_

**SEALED RFB ENVELOPE LABEL**

Cut along the outer border and affix this label to your sealed solicitation envelope to identify it as a "Sealed RFB".

PLEASE PRINT CLEARLY

<b>SEALED RFB DOCUMENTS – DO NOT OPEN</b>	
RFB #: _____	
RFB TITLE: _____	
DATE DUE: _____	
TIME DUE: _____	
SUBMITTED BY: _____	
(Name of Company)	
_____	_____
e-mail address	Telephone
Deliver to:	
<b>City of North Port</b>	
<b>Finance Department - Purchasing Division</b>	
<b>Keith Raney, Contract Administrator II</b>	
<b>4970 City Hall, 3 RD Floor, Suite 337</b>	
<b>North Port, Florida 34286</b>	
<b>RFB NO. 2023-04</b>	
<b>RENOVATION OF LIFT STATIONS 29, 45 AND 73</b>	

Note: Submissions received after the time and date stated on the Notice of Availability will not be accepted.

ATTACHMENT 1:

# BID SCHEDULE IN EXCEL FORMAT

## SEPARATE ATTACHMENT

- DO NOT RECREATE
- SUBMIT AN (1) ORIGINAL AND (1) HARD COPY
- DO NOT PDF EXCEL SPREADSHEET SAVE IN EXCEL FORMAT ON USB DRIVE

It is understood that the estimated summary of pay item quantities are approximate only and are solely for the purpose of facilitating the comparison of bids, and that the Contractor's compensation shall be computed upon the basis of the actual quantities in the completed work, whether they be more or less than those shown.

Preparation of Bid Schedules: Contractor **MUST** use the City provided excel spreadsheet. **DO NOT RECREATE FORM**. All GREEN spaces in the Bid Form to be filled. *Bidder should not reference the words "No Charge, N/A, included, dash, etc." in any of the spaces. Bidder must identify a monetary amount for each UNIT COST (unless the unit price is "x" out by the City). UNIT COST prevails over EXTENDED COST. Failure to identify a monetary amount in any of the UNIT COST line items shall cause Bidder to be deemed non-responsive and bid response be rejected.* In case of discrepancy between unit price and extended price, the unit price will govern. Apparent errors in extension will be corrected.

**ATTACHMENT 2:  
INSURANCE REQUIREMENTS**

Contractor and subcontractors shall procure and maintain until all of their obligations have been discharged, including any warranty periods under this Contract are satisfied, insurance against claims for injury to persons or damage to property which may arise from or in connection with the performance of the work hereunder by the Contractor, his agents, representatives, employees or subcontractors.

The insurance requirements herein are minimum requirements for this Contract and in no way limit the indemnity covenants contained in this Contract. The City in no way warrants that the minimum limits contained herein are sufficient to protect the Contractor from liabilities that might arise out of the performance of the work under this Contract by the Contractor, his agents, representatives, employees, or subcontractors. Contractor is free to purchase such additional insurance as may be determined necessary.

**LIMITS OF INSURANCE** - Contractor shall provide coverage with limits of liability not less than those stated below. An excess liability policy or umbrella liability policy may be used to meet the minimum liability requirements provided that the coverage is written on a “following form” basis.

**Requirements:**

**1. Commercial General Liability – Occurrence Form (CG 00 01)**

Policy shall include bodily injury, property damage, broad form contractual liability and Explosion, Collapse and Underground (XCU) coverage. The general aggregate limit shall apply separately to this project/location or the general aggregate limit shall be twice the required occurrence limit.

The Contractor shall procure and maintain, and require all subcontractors to procure and maintain a comprehensive general liability policy, including, but not limited to

- General Aggregate \$1,000,000
- Each Occurrence \$1,000,000
- products and completed ops \$1,000,000
- damage to rented premises \$100,000
- fire damage \$100,000

- a) The policy shall be endorsed to include the following **additional insured language**: "City of North Port and its officers, employees, agents and volunteers" shall be named as an additional insured with respect to liability arising out of the activities performed by, or on behalf of the Contractor.
- b) Contractor's subcontractors shall be subject to the same minimum requirements identified above.
- c) Policy shall be endorsed for a waiver of subrogation against the City of North Port.

**2. Commercial Automobile Liability**

Bodily injury and property damage for any owned, hired, and non-owned vehicles used in the performance of this Contract. Automobile liability must be written on a standard ISO form (CA 00 01) covering any auto (Code 1), or if Contractor has no owned autos, hired (Code 8) and non-owned (Code 9) autos.

- Combined Single Limit (CSL) (Ea Accident) \$1,000,000
- Bodily Injury (per person) \$1,000,000
- Bodily Injury (per accident) \$1,000,000
- Property Damage (per accident) \$1,000,000

**RFB No. 2023-04 RENOVATION OF LIFT STATIONS 29, 45 AND 73**

- a. The policy shall be endorsed to include the following **additional insured language**: "City of North Port and its officers, employees, agents and volunteers" shall be named as an additional insured with respect to liability arising out of the activities performed by, or on behalf of the Contractor, including automobiles owned, leased, hired or borrowed by the Contractor".
- b. Contractor's sub-contractors shall be subject to the same minimum requirements identified in this section.
- c. Policy shall contain a waiver of subrogation against the City of North Port.

**3. Worker's Compensation and Employers' Liability (PER CHAPTER 440. FLORIDA STATUTES)**

The Contractor shall procure and maintain Worker's Compensation insurance for all his employees to be engaged in work on the project under this Contract and, in case any such work is sublet, the Contractor shall require the subcontractor similarly to provide Worker's Compensation insurance for all of the latter's employees to be engaged in such work unless such employees are covered by protection afforded by the Contractor's Workers Compensation insurance. For additional information contact the Department of financial Services, Workers' Compensation Division at 850.413.1601 or on the web at [www.fldfs.com](http://www.fldfs.com). In case any class of employees engaged in hazardous work on the project under this Contract is not protected under the Worker's Compensation Statute, the Contractor shall provide, and shall cause each subcontractor to provide, Employer's Liability Insurance for the protection of such of his employees not otherwise protected under such provisions. The minimum liability limits of such insurance shall not be less than herein specified or in that amount specified by law for that type of damage claim.

Proof of such insurance shall be filed by the Contractor with the City within ten (10) days after the execution of this Contract.

**Workers' Compensation Employers' Liability**

- Each Accident, each employee, bodily injury or disease \$1,000,000
- a. Policy shall contain a waiver of subrogation against the City of North Port.
  - b. Contractor's sub-contractors shall be subject to the same minimum requirements identified in this section.
  - c. If the contractor has no employees, the contractor must submit to the City the Workers Compensation Exemption from the State of Florida.

**4. Contractors' Pollution Legal Liability (if project involves environmental hazards).**

- Each Occurrence or Claim \$100,000
- Policy Aggregate \$300,000

**GENERAL REQUIREMENTS:**

**A.** The City of North Port is to be named additional insured on **Comprehensive Commercial General Liability Policy and Auto Policy**. All certificates of insurance must be on file with and approved by the City before commencement of any work activities under this Contract.

Any and all deductibles to the above referenced policies are to be the responsibility of the Contractor. The Contractor's insurance is considered primary for any loss regardless of any insurance maintained by the City. The Contractor is responsible for all insurance policy premiums, deductibles, or SIR (self-insured retentions) or any loss or portion of any loss that is not covered by any available insurance policy.

All insurance policies must be issued by companies of recognized responsibility licensed to do business in Florida and must contain a provision that prohibits cancellation unless the City is provided notice as stated within the policy. It is the Contractor's responsibility to provide notice to the City.

**B. WAIVER OF SUBROGATION:** All required insurance policies, with the exception of Workers Compensation, are to be endorsed with a waiver of subrogation. The insurance companies, by proper endorsement or thru other means, agrees to waive all rights of subrogation against the City, its officers, officials, employees and volunteers, and the City's insurance carriers, for losses paid under the terms of these policies that arises from the contractual relationship or work performed by the Contractor for the City. It is the Contractor's responsibility to notify their insurance company of the Waiver of Subrogation and request written authorization or the proper endorsement. Additionally, the Contractor, its officers, officials, agents, employees, volunteers, and any Subcontractors, agrees to waive all rights of subrogation against the City and its insurance carriers for any losses paid, sustained or incurred, but not covered by insurance, that arise from the contractual relationship or work performed. This waiver also applies to any deductibles or self-insured retentions the Contractor or its agents may be responsible for.

**C. POLICY FORM:**

1. All policies, required by this Contract, **with the exception of Workers Compensation**, or unless specific approval is given by Risk Management through the City's Purchasing Office, are to be **written on an occurrence basis**, shall name the City of North Port, its Commissioners, officers, agents, employees and volunteers as additional insured as their interest may appear under this Contract. Insurer(s), with the exception of Professional Liability and Workers Compensation, shall agree to waive all rights of subrogation against the City of North Port, its Commissioners, officers, agents, employees, or volunteers.
2. Insurance requirements itemized in this Contract, and required of the Contractor, shall be provided by or on behalf of all subcontractors to cover their operations performed under this Contract. The Contractor shall be held responsible for any modifications, deviations, or omissions in these insurance requirements as they apply to subcontractors.
3. Each insurance policy required by this Contract shall:
  - a. Apply separately to each insured against whom claim is made and suit is brought, except with respect to limits of the insurer's liability.
  - b. Be endorsed to state that coverage shall not be suspended, voided or cancelled by either party except after notice is delivered in accordance with the policy provisions. The Contractor is to notify the City Purchasing Office by written notice via certified mail, return receipt requested.
4. The City shall retain the right to review, at any time, coverage, form, and amount of insurance.
5. The procuring of required policies of insurance shall not be construed to limit Contractor's liability nor to fulfill the indemnification provisions and requirements of this Contract. The extent of Contractor's liability for indemnity of the City shall not be limited by insurance coverage or lack thereof, or unreasonably delayed for any reason, including but not limited to, insurance coverage disputes between the Contractor and its carrier.
6. The Contractor shall be solely responsible for payment of all premiums for insurance contributing to the satisfaction of this Contract and shall be solely responsible for the payment of all deductibles and retentions to which such policies are subject, whether or not the City is an insured under the policy.
7. Claims Made Policies will be accepted for professional and hazardous materials and such other risks as are authorized by the City's Risk Office. All Claims Made Policies contributing to the satisfaction of the insurance requirements herein shall have an extended reporting period option or automatic coverage of not less than two (2) years. If provided as an option, the Contractor agrees to purchase the extended reporting period on cancellation or termination unless a new policy is affected with a retroactive date, including at least the last policy year.

**RFB No. 2023-04 RENOVATION OF LIFT STATIONS 29, 45 AND 73**

8. Certificates of Insurance Evidencing Claims Made or Occurrences form coverage and conditions to this Contract, as well as the contract number and description of work, are to be furnished to the City’s Purchasing Office (4970 City Hall Boulevard, Suite 337, North Port, FL 34286) prior to commencement of work AND a minimum of thirty (30) calendar days prior to expiration of the insurance contract when applicable. All insurance certificates shall be received by the City’s Purchasing Office before the Contractor will be allowed to commence or continue work. The Certificate of Insurance issued by the underwriting department of the insurance carrier shall certify compliance with the insurance requirements provided herein.

**Bidders should carefully review their existing insurances and consider their ability to meet these requirements prior to submission. The requirements should be forwarded to their agent, broker, and insurance providers for review**

Unless otherwise specified, it shall be the responsibility of the contractor to ensure that all subcontractors comply with the same insurance requirements spelled out above.

All certificates of insurance must be on file with and approved by the City of North Port Risk Division before the commencement of any work activities.

Bidder Statement:

We understand the requirements requested and agree to fully comply.

**BIDDER’S NAME** \_\_\_\_\_ **TITLE** \_\_\_\_\_

**AUTHORIZED SIGNATURE** \_\_\_\_\_ **DATE** \_\_\_\_\_

***THIS PAGE MUST BE COMPLETED AND SUBMITTED***



**ATTACHMENT 3:  
BID FORM**

Name of Bidder/Company Name: \_\_\_\_\_  
Business Address: \_\_\_\_\_  
City/State/Zip Code: \_\_\_\_\_  
Bidder/Company Telephone Number: \_\_\_\_\_  
E-mail Address: \_\_\_\_\_  
Contractor License #: \_\_\_\_\_  
FEID #: \_\_\_\_\_

To the City Commission of the City of North Port pursuant to and in compliance with your notice inviting sealed bids (Invitation to Bid), Instructions to Bidders, and the other documents relating thereto, the undersigned Bidder, having familiarized himself/herself with the terms of the Contract documents, local conditions affecting the performance of the Contract, and the cost of the work at the place where the work is to be done, hereby proposes and agrees to perform within the time stipulated in the Contract, including all of its component parts and everything required to be performed, and to provide and furnish any and all of the labor, material, tools, expendable equipment, and all utility and transportation services and design of certain items necessary to perform the Contract and complete in a workmanlike manner, all of the work required in connection with the construction of said work all in strict conformity with the plans and specifications and other Contract documents for the prices hereinafter set forth.

The undersigned, as Bidder, does hereby declare that he has read the Request for Bids, Instructions to Bidders, General Provisions, Special Provisions, Technical Specifications & Conditions, Attachments, Exhibits, Insurance Requirements, Bid Form, Permit Fees, Plan Revisions, Plans, and any other reports or documentation for: **RFB NO. 2022-XX RENOVATION OF LIFT STATIONS 29, 45 AND 73** and further agrees to furnish all items listed on the attached Bid Form in accordance with the unit price line items as indicated on the bid schedule form(s) submitted. The above specified documents are herein incorporated into the Bid Form.

The undersigned as Bidder, declares that the only persons or parties interested in this submittal as principals are those named herein: that this submittal is made without collusion with any person, firm, or corporation: and he/she proposes and agrees, if the proposal is accepted, that he/she will execute a Contract with the City in the form set forth in the Contract documents and that he/she will accept in full payment thereof the following prices, to wit:

**PROJECT TOTAL:** \_\_\_\_\_ \$ \_\_\_\_\_

Through the signing of this Bid Form, Bidder attests his/her bid is guaranteed for a period of not less than **NINETY (90) DAYS** from the date of the official bid opening.

Date: \_\_\_\_\_

Signed (*Person authorized to bind the company*): \_\_\_\_\_

Name (printed): \_\_\_\_\_ Title: \_\_\_\_\_

**THIS PAGE MUST BE COMPLETED AND SUBMITTED**

ATTACHMENT 4:

STATEMENT OF ORGANIZATION

The following information will be provided to the City of North Port for incorporation in legal documents. It is, therefore, vital all information is accurate and complete. Please be certain all spelling, and capitalization is exactly as registered with the state or federal government.

Company Name \_\_\_\_\_

Telephone # \_\_\_\_\_ E-Mail \_\_\_\_\_ Fax # \_\_\_\_\_

Main Office Address \_\_\_\_\_

City \_\_\_\_\_ State \_\_\_\_\_ Zip Code \_\_\_\_\_

Address of Office Servicing City of North Port, if different than above:  SAME AS ABOVE

Office Address \_\_\_\_\_

City \_\_\_\_\_ State \_\_\_\_\_ Zip Code \_\_\_\_\_

Telephone # \_\_\_\_\_ E-mail \_\_\_\_\_ Fax # \_\_\_\_\_

Name & Title of Firm Representative \_\_\_\_\_

Federal Identification Number: \_\_\_\_\_

Bidder shall submit proof that it is authorized to do business in the State of Florida unless registration is not required by law.

(Please Check One)

Is this a Florida Corporation:  Yes or  No

If not a Florida Corporation,

In what state was it created: \_\_\_\_\_

Name as spelled in that State: \_\_\_\_\_

What kind of corporation is it:  "For Profit" or  "Not for Profit"

Is it in good standing:  Yes or  No

Authorized to transact business in Florida:  Yes or  No

State of Florida Department of State Certificate of Authority Document No.: \_\_\_\_\_

Does it use a registered fictitious name:  Yes or  No

**Names of Officers:**

**President:** \_\_\_\_\_ **Secretary:** \_\_\_\_\_

**Vice President:** \_\_\_\_\_ **Treasurer:** \_\_\_\_\_

**Director:** \_\_\_\_\_ **Director:** \_\_\_\_\_

**Other:** \_\_\_\_\_ **Other:** \_\_\_\_\_

**Name of Corporation (As used in Florida):**

\_\_\_\_\_  
(Spelled exactly as it is registered with the state or federal government)

**Corporate Address:**

Post Office Box: \_\_\_\_\_  
City, State Zip: \_\_\_\_\_  
Street Address: \_\_\_\_\_  
City, State, Zip: \_\_\_\_\_

STATE OF FLORIDA  
COUNTY OF \_\_\_\_\_

Sworn to (or affirmed) and subscribed before me by means of  physical presence or  online notarization, this \_\_\_ day of \_\_\_\_\_ 2022, by \_\_\_\_\_.

\_\_\_\_\_  
Notary Public – State of Florida

Personally Known \_\_\_\_\_ OR Produced Identification \_\_\_\_\_  
Type of Identification Produced \_\_\_\_\_

**Date:** \_\_\_\_\_

**Signed (Person authorized to bind the company):** \_\_\_\_\_

**Name (printed):** \_\_\_\_\_ **Title:** \_\_\_\_\_

***THIS PAGE MUST BE COMPLETED AND SUBMITT***

**ATTACHMENT 5:**

**ADDENDA AND BOND INFORMATION**

The undersigned acknowledges receipt of the following addenda, and the cost, if any, of such revisions has been included in the bid price.

<b>Addendum No.</b>		Dated		<b>Addendum No.</b>		Dated	
<b>Addendum No.</b>		Dated		<b>Addendum No.</b>		Dated	
<b>Addendum No.</b>		Dated		<b>Addendum No.</b>		Dated	
<b>Addendum No.</b>		Dated		<b>Addendum No.</b>		Dated	

**BID BOND AND PERFORMANCE/PAYMENT BOND (SEE ATTACHMENTS 17 & 18)**

**BID BOND: ACCOMPANYING THIS PROPOSAL IS \_\_\_\_\_**

**(insert: “cash”, “Bidder’s bond”, or “certified check”, as the case may be)** in an amount equal to at least 5% of the total amount of the bid, payable to the City of North Port. Cashier’s checks will be returned to all Bidders after award of bid. If supplying a bid bond please use the attached bid bond form. **Note: Failure to submit a bid bond will be cause for rejection of bid.**

The undersigned deposits the above-named security as a proposal guarantee and agrees that it shall be forfeited to the City as liquidated damages in case this proposal is accepted by the City and the undersigned fails to execute a Contract with the City as specified in the Contract documents accompanied by the required labor and material and faithful performance bonds with sureties satisfactory to the City, and accompanied by the required certificates of insurance coverage. Should the City be required to engage the services of an attorney in connection with the enforcement of this bid, Bidder promises to pay City’s reasonable attorneys’ fees incurred with or without suit.

The undersigned agrees, if awarded this bid, to furnish a **PERFORMANCE AND PAYMENT BOND** in the amount of 100% of the total project price within ten (10) calendar days after notification of award to the Purchasing Department. The undersigned shall be responsible and bear all costs associated to record Performance and Payment Bond with Sarasota County Clerk’s Office. Receipt of said recording and a certified copy of the Bond shall be furnished to the Purchasing Division at the time of the pre-construction meeting.

**All Contract documents (i.e.: performance and payment bond, cashier’s check, bid bond) shall be in the name of “City of North Port”.**

**Date:** \_\_\_\_\_

**Signed (Person authorized to bind the company):** \_\_\_\_\_

**Name (printed):** \_\_\_\_\_ **Title:** \_\_\_\_\_

***THIS PAGE MUST BE COMPLETED AND SUBMITTED***

ATTACHMENT 6:

EQUIPMENT AND SUBCONTRACTOR/SUPPLIER LIST

Equipment is located at: \_\_\_\_\_

Please make sure your list of equipment contains the following: Description of equipment, inclusive of manufacturer, year and condition.

List the condition of equipment/vehicles utilized for this project in accordance with the following scale:

1-Excellent: 2-Good: 3-Fair: 4-Poor. (Attach additional sheets, if required.)

Description	Manufacturer	Year	Condition	Leased/Owned
1. _____				
2. _____				
3. _____				

SOURCE OF SUPPLY AND SUBCONTRACTOR FORM

The following sources of supply and subcontractors shall be used for the RFB NO. 2023-04 RENOVATION OF LIFT STATIONS 29, 45 AND 73. If Bidder does not have a source of supply or subcontractor, insert "to be determined". When a source or subcontractor is determined, selection will be subject to City approval. (If not applicable, state N/A).

SUBCONTRACTOR(S)

(PLEASE INCLUDE ADDRESS/TELEPHONE NUMBER & E-MAIL)

1. \_\_\_\_\_
2. \_\_\_\_\_
3. \_\_\_\_\_

SUPPLIER(S)

1. \_\_\_\_\_
2. \_\_\_\_\_
3. \_\_\_\_\_

Date: \_\_\_\_\_

Signed (Person authorized to bind the company): \_\_\_\_\_

Name (printed): \_\_\_\_\_ Title: \_\_\_\_\_

**THIS PAGE MUST BE COMPLETED AND SUBMITTED**

**ATTACHMENT 7:  
QUALIFICATIONS AND REFERENCES**

Prime bidder must be fully licensed to do business in the State of Florida and be currently licensed as a Certified General Contractor in the State of Florida and provide proof of licensure with the submitted Bid Proposal. Bidders must have successfully completed, as a Prime or Subcontractor, at least four (4) projects, in the past five (5) years of similar type, size and dollar value of the project described herein.

1. Business/Customer Name: \_\_\_\_\_

Name of Contact Person/Title: \_\_\_\_\_

Telephone# \_\_\_\_\_ Fax \_\_\_\_\_ E-mail \_\_\_\_\_

Address \_\_\_\_\_

Phone Number \_\_\_\_\_

Duration of Contract or business relationship \_\_\_\_\_

Type of Services Provided \_\_\_\_\_

Contract Period: FROM \_\_\_\_\_ TO \_\_\_\_\_

Contract Price \$ \_\_\_\_\_ Contract Price at Completion of the Project \$ \_\_\_\_\_

2. Business/Customer Name: \_\_\_\_\_

Name of Contact Person/Title: \_\_\_\_\_

Telephone# \_\_\_\_\_ Fax \_\_\_\_\_ E-mail \_\_\_\_\_

Address \_\_\_\_\_

Phone Number \_\_\_\_\_

Duration of Contract or business relationship \_\_\_\_\_

Type of Services Provided \_\_\_\_\_

Contract Period: FROM \_\_\_\_\_ TO \_\_\_\_\_

Contract Price \$ \_\_\_\_\_ Contract Price at Completion of the Project \$ \_\_\_\_\_

Date: \_\_\_\_\_

Signed (*Person authorized to bind the company*): \_\_\_\_\_

Name (printed): \_\_\_\_\_ Title: \_\_\_\_\_

**THIS PAGE MUST BE COMPLETED AND SUBMITTED**

**RFB No. 2023-04 RENOVATION OF LIFT STATIONS 29, 45 AND 73**

3. Business/Customer Name: \_\_\_\_\_

Name of Contact Person/Title: \_\_\_\_\_

Telephone# \_\_\_\_\_ Fax \_\_\_\_\_ E-mail \_\_\_\_\_

Address \_\_\_\_\_

Contract Period: FROM \_\_\_\_\_ TO \_\_\_\_\_

Contract Price \$ \_\_\_\_\_ Contract Price at Completion of the Project \$ \_\_\_\_\_

Phone Number \_\_\_\_\_

Duration of Contract or business relationship \_\_\_\_\_

Type of Services Provided \_\_\_\_\_

Contract Period: FROM \_\_\_\_\_ TO \_\_\_\_\_

Contract Price \$ \_\_\_\_\_ Contract Price at Completion of the Project \$ \_\_\_\_\_

4. Business/Customer Name: \_\_\_\_\_

Name of Contact Person/Title: \_\_\_\_\_

Telephone# \_\_\_\_\_ Fax \_\_\_\_\_ E-mail \_\_\_\_\_

Address \_\_\_\_\_

Phone Number \_\_\_\_\_

Duration of Contract or business relationship \_\_\_\_\_

Type of Services Provided \_\_\_\_\_

Contract Period: FROM \_\_\_\_\_ TO \_\_\_\_\_

Contract Price \$ \_\_\_\_\_ Contract Price at Completion of the Project \$ \_\_\_\_\_

**Date:** \_\_\_\_\_

**Signed (Person authorized to bind the company):** \_\_\_\_\_

**Name (printed):** \_\_\_\_\_ **Title:** \_\_\_\_\_

**THIS PAGE MUST BE COMPLETED AND SUBMITTED**

ATTACHMENT 8:

NON-COLLUSIVE AFFIDAVIT

State of \_\_\_\_\_

County of \_\_\_\_\_

Before me, the undersigned authority, personally appeared:

\_\_\_\_\_ who, being first duly sworn, deposes and says that:

1. He/She is the \_\_\_\_\_ (Owner, Partner, Officer, Representative or Agent) of \_\_\_\_\_, the Respondent that has submitted the attached reply:

2. He/She is fully informed respecting the preparation and contents of the attached reply and of all pertinent circumstances respecting such reply:

3. Such reply is genuine and is not a collusive or sham reply:

4. Neither the said Respondent nor any of its officers, partners, owners, agents, representatives, employees or parties in interest, including this affiant, have in any way colluded, conspired, connived or agreed, directly or indirectly, with any other respondent, firm, or person to submit a collusive or sham reply in connection with the work for which the attached reply has been submitted: or have in any manner, directly or indirectly sought by agreement or collusion, or communication or conference with any respondent, firm, or person to fix the price or prices in the attached reply or of any other respondent, or to fix any overhead, profit, or cost elements of the reply price or the reply price of any other respondent, or to secure through any collusion, conspiracy, connivance, or unlawful agreement any advantage against (Recipient), or any person interested in the reply work.

Signed, sealed and delivered this \_\_\_\_\_ day of \_\_\_\_\_, 20\_\_\_\_\_.

By: \_\_\_\_\_  
(Printed Name)

(Title)

STATE OF FLORIDA

COUNTY OF \_\_\_\_\_

Sworn to (or affirmed) and subscribed before me by means of \_\_\_ physical presence or \_\_\_ online notarization, this \_\_\_ day of \_\_\_\_\_ 2022, by \_\_\_\_\_.

\_\_\_\_\_  
Notary Public – State of Florida

Personally Known \_\_\_\_\_ OR Produced Identification \_\_\_\_\_

Type of Identification Produced \_\_\_\_\_

**THIS PAGE MUST BE COMPLETED AND SUBMITTED**



**ATTACHMENT 9:  
CONFLICT OF INTEREST FORM**

F.S. §112.313 places limitations on public officers (including advisory board members) and employees' ability to Contract with the City either directly or indirectly. Therefore, please indicate if the following applies:

**PART I.**

\_\_\_\_\_ I am an employee, public officer or advisory board member of the City

\_\_\_\_\_ (List Position Or Board)

\_\_\_\_\_ I am the spouse or child of an employee, public officer or advisory board member of the City

**Name:** \_\_\_\_\_

\_\_\_\_\_ An employee, public officer or advisory board member of the City, or their spouse or child, is an officer, partner, director, or proprietor of Respondent or has a material interest in Respondent. "Material interest" means direct or indirect ownership of more than 5 percent of the total assets or capital stock of any business entity. For the purposes of [§112.313], indirect ownership does not include ownership by a spouse or minor child.

**Name:** \_\_\_\_\_

\_\_\_\_\_ Respondent employs or Contracts with an employee, public officer or advisory board member of the City.

**Name:** \_\_\_\_\_

\_\_\_\_\_ None of The Above

**PART II: Are you going to request an advisory board member waiver?**

\_\_\_\_\_ I will request an advisory board member waiver under §112.313(12)

\_\_\_\_\_ I will NOT request an advisory board member waiver under §112.313(12)

\_\_\_\_\_ N/A

The City shall review any relationships which may be prohibited under the Florida Ethics Code and will disqualify any Bidders whose conflicts are not waived or exempt.

**Date:** \_\_\_\_\_

**Signed (Person authorized to bind the company):** \_\_\_\_\_

**Name (printed):** \_\_\_\_\_ **Title:** \_\_\_\_\_

**THIS PAGE MUST BE COMPLETED AND SUBMITTED**

ATTACHMENT 10:  
PUBLIC ENTITY CRIME INFORMATION

As provided by F.S. §287.133, a person or affiliate who has been placed on the convicted vendor list following a conviction for a public entity crime may not submit a bid on a Contract to provide any goods or services to a public entity, may not submit a bid on a Contract with a public entity for the construction or repair of a public building or public work, may not submit bids on leases of real property to a public entity, may not be awarded or perform work as a Contractor, supplier, Subcontractor, or Consultant under a Contract with any public entity, and may not transact business with any public entity in excess of the threshold amount provided in Section 287, for CATEGORY TWO for a period of 36 months from the date of being placed on the convicted vendor list.

I, \_\_\_\_\_, being an authorized representative of the Respondent \_\_\_\_\_,

Located at: \_\_\_\_\_

City: \_\_\_\_\_ State: \_\_\_\_\_ Zip Code: \_\_\_\_\_, have read and understand the contents above. I further certify that Respondent is not disqualified from replying to this solicitation because of F.S. §287.133.

Signature: \_\_\_\_\_ Date: \_\_\_\_\_

Telephone #: \_\_\_\_\_ Fax #: \_\_\_\_\_

Federal ID #: \_\_\_\_\_ E-mail: \_\_\_\_\_

State of \_\_\_\_\_

County of \_\_\_\_\_

STATE OF FLORIDA

COUNTY OF \_\_\_\_\_

Sworn to (or affirmed) and subscribed before me by means of \_\_\_\_ physical presence or \_\_\_\_ online notarization, this \_\_\_\_ day of \_\_\_\_\_ 2022, by \_\_\_\_\_.

\_\_\_\_\_  
Notary Public – State of Florida

Personally Known \_\_\_\_\_ OR Produced Identification \_\_\_\_\_

Type of Identification Produced \_\_\_\_\_

Date: \_\_\_\_\_

Signed (Person authorized to bind the company): \_\_\_\_\_

Name (printed): \_\_\_\_\_ Title: \_\_\_\_\_

**THIS PAGE MUST BE COMPLETED AND SUBMITTED**

**ATTACHMENT 11:  
DRUG-FREE WORKPLACE FORM**

The undersigned Respondent in accordance with Florida Statute §287.087 hereby certifies that: \_\_\_\_\_ ( Company Name) does:

1. Publish a statement notifying employees that the unlawful manufacture, distribution, dispensing, possession, or use of a controlled substance is prohibited in the workplace and specifying the actions that will be taken against employees for violations of such prohibition.
2. Inform employees about the dangers of drug abuse in the workplace, the business’s policy of maintaining a drug free workplace, any available drug counseling, rehabilitation, and employee assistance programs, and the penalties that may be imposed upon employees for drug abuse violations.
3. Give each employee engaged in providing the commodities or Contractual services that are under bid a copy of the statement specified in subsection (1).
4. In the statement specified in subsection (1), notify the employees that, as a condition of working on the commodities or Contractual services that are under bid, the employee will abide by the terms of the statement and will notify the employer of any conviction of, or plea of guilty or nolo contendere to, any violation of Chapter 893 or of any controlled substance law of the United States or any state, for a violation occurring in the workplace no later than five (5) days after such conviction.
5. Impose a sanction on, or require the satisfactory participation in a drug abuse assistance or rehabilitation program if such is available in the employee’s community, by any employee who is so convicted.
6. Make a good faith effort to continue to maintain a drug free workplace through implementation of this section.  
As the person authorized to sign the statement, I certify that Respondent complies fully with the above requirements.

**Check one:**

\_\_\_\_\_As the person authorized to sign this statement, I certify that this firm complies fully with above requirements.

\_\_\_\_\_As the person authorized to sign this statement, this firm **does not** comply fully with the above requirements.

\_\_\_\_\_  
**Signature**

\_\_\_\_\_  
**Print Name**

\_\_\_\_\_  
**Date**

**THIS PAGE MUST BE COMPLETED AND SUBMITTED**

**ATTACHMENT 13:  
SWORN STATEMENT: THE FLORIDA TRENCH SAFETY ACT  
(If applicable)**

THIS FORM MUST BE SIGNED IN THE PRESENCE OF A NOTARY PUBLIC BY AN OFFICER AUTHORIZED TO ADMINISTER OATHS.

1. This Sworn Statement is submitted with Bid No. 2023-04 for the construction of \_\_\_\_\_
2. This Sworn Statement is submitted by \_\_\_\_\_ whose business address is \_\_\_\_\_ and (if applicable) its Federal Employer Identification Number (FEIN) is \_\_\_\_\_.
3. My name is \_\_\_\_\_ (PRINTED OR TYPED NAME OF INDIVIDUAL SIGNING) and hold the position of \_\_\_\_\_ with the above entity.
4. The Trench Safety Standards that will be in effect during the construction of this Project are Florida Statute Section 553.60-55.64, Trench Safety Act, and OSHA Standard.
5. The undersigned assures that the entity will comply with the applicable Trench Safety Standards and agrees to indemnify and hold harmless the County and ENGINEER, and any of their agents or employees from any claims arising from the failure to comply with said standard.
6. The undersigned has appropriated \$ \_\_\_\_\_ per linear foot of trench to be excavated over 5' deep for compliance with the applicable standards and intends to comply by instituting the following procedures:
7. The undersigned has appropriated \$ \_\_\_\_\_ per square foot for compliance with shoring safety requirements and intends to comply by instituting the following procedures:
8. The undersigned, in submitting this Bid, represents that he or she has reviewed and considered all available geotechnical information and made such other investigations and tests as he or she may deem necessary to adequately design the trench safety system(s) he or she will utilize on this Project.

\_\_\_\_\_  
Authorized Signature/Title

Sworn to and subscribed before me  
this \_\_\_\_\_  
(date)

\_\_\_\_\_  
Notary Public Signature

(Notary Seal)

My Commission Expires: \_\_\_\_\_

**THIS PAGE MUST BE COMPLETED AND SUBMITTED**

ATTACHMENT 14:

Scrutinized Company Certification Form

Company Name: \_\_\_\_\_

Authorized Representative Name and Title: \_\_\_\_\_

Address: \_\_\_\_\_ City: \_\_\_\_\_ State: \_\_\_\_\_ ZIP: \_\_\_\_\_

Phone Number: \_\_\_\_\_ Email Address: \_\_\_\_\_

A company is ineligible to, and may not, bid on, submit a proposal for, or enter into or renew a Contract with the City of North Port for goods or services of any amount if, at the time of bidding on, submitting a proposal for, or entering into or renewing such Contract, the company is on the Scrutinized Companies that Boycott Israel List, created pursuant to Florida Statutes, section 215.4725, or is engaged in a boycott of Israel.

A company is ineligible to, and may not, bid on, submit a proposal for, or enter into or renew a Contract with the City of North Port for goods or services of \$1 million or more if, at the time of bidding on, submitting a proposal for, or entering into or renewing such Contract, the company is on the Scrutinized Companies with Activities in Sudan List, the Scrutinized Companies with Activities in the Iran Petroleum Energy Sector List, created pursuant to Florida Statutes, section 215.473, or with companies engaged in business operations in Cuba or Syria.

**CHOOSE ONE OF THE FOLLOWING**

\_\_\_\_\_ This bid, proposal, Contract or Contract renewal is for goods or services of less than \$1 million. As the person authorized to sign on behalf of the above-named company, and as required by Florida Statutes, section 287.135(5), I hereby certify that the above-named company is not participating in a boycott of Israel.

\_\_\_\_\_ This bid, proposal, Contract or Contract renewal is for goods or services of \$1 million or more. As the person authorized to sign on behalf of the above-named company, and as required by Florida Statutes, section 287.135(5), I hereby certify that the above-named company is not participating in a boycott of Israel, is not on the Scrutinized Companies with Activities in Sudan List or the Scrutinized Companies with Activities in the Iran Petroleum Energy Sector List, and it does not have business operations in Cuba or Syria.

I understand that pursuant to Florida Statutes, section 287.135, the submission of a false certification may result in the termination of the Contract if one is entered into, and may subject the above-named company to civil penalties, attorney's fees and costs.

Certified By: \_\_\_\_\_  
AUTHORIZED REPRESENTATIVE SIGNATURE

Print Name and Title: \_\_\_\_\_

Date Certified: \_\_\_\_\_

*Solicitation/Contract/PO Number (Completed by Purchasing):* \_\_\_\_\_

**THIS PAGE MUST BE COMPLETED AND SUBMITTED)**

ATTACHMENT 15:

LOBBYING CERTIFICATION

“The undersigned hereby certifies, to the best of his or her knowledge and belief, that”:

STATE OF \_\_\_\_\_

COUNTY OF \_\_\_\_\_

This \_\_\_\_\_ day \_\_\_\_\_ of 2022 \_\_\_\_\_, being first duly sworn, deposes and says that he or she is the authorized representative of \_\_\_\_\_ (Name of the Contractor, firm or individual), and that the vendor and any of its agents agree to have no contact or communication with, or discuss any matter related in any way to any active City of North Port solicitation, with any City of North Port elected officials, officers, their appointees or their agents or any other staff or outside individuals working with the City in respect to this request other than the designated Procurement Official Contact and to abide by the restrictions outlined in the General Terms and Conditions of the Solicitation. Technical questions directed to the project manager, is prohibited. These persons shall not be lobbied, either individually or collectively, regarding any questions for bid, proposal, qualification and/or any other solicitations released by the City. To do so is grounds for immediate disqualification from the selection process. The selection process is not considered final until such a time as the Commission has made a final and conclusive determination.

(a) No City appropriated funds have been paid or will be paid, by or on behalf of the undersigned, to any person for influencing or attempting to influence either directly or indirectly an officer or employee of the City, City Commission in connection with the awarding of any City Contract.

(b) If any funds other than City appropriated funds have been paid or will be paid to any person for influencing or attempting to influence a member of City Commission or an officer or employee of the City in connection with this Contract, the undersigned shall complete and submit Standard Form-L “Disclosure Form to Report Lobbying”, in accordance with its instructions.

Signed, sealed and delivered this \_\_\_\_\_ day of \_\_\_\_\_, 2022.

By: \_\_\_\_\_

\_\_\_\_\_  
(Printed Name)

\_\_\_\_\_  
(Title)

STATE OF FLORIDA

COUNTY OF \_\_\_\_\_

Sworn to (or affirmed) and subscribed before me by means of \_\_\_\_\_ physical presence or \_\_\_\_\_ online notarization, this \_\_\_\_ day of \_\_\_\_\_ 2022, by \_\_\_\_\_.

\_\_\_\_\_  
Notary Public – State of Florida

Personally Known \_\_\_\_\_ OR Produced Identification \_\_\_\_\_

Type of Identification Produced \_\_\_\_\_

**THIS PAGE MUST BE COMPLETED AND SUBMITTED**

ATTACHMENT 16:  
VENDOR'S CERTIFICATION FOR E-VERIFY SYSTEM

STATE OF \_\_\_\_\_  
COUNTY OF \_\_\_\_\_

The undersigned Vendor/Consultant/Contractor (Vendor), after being duly sworn, states the following:

1. Vendor is a person or entity that has entered into or is attempting to enter into a contract with the City of North Port (City) to provide labor, supplies, or services to the City in exchange for salary, wages or other remuneration.
2. Vendor has registered with and will use the E-Verify System of the United States Department of Homeland Security to verify the employment eligibility of:
  - a. All persons newly hired by the Vendor to perform employment duties within Florida during the term of the contract; and
  - b. All persons, including sub-contractors, sub-vendors or sub-consultants, assigned by the Vendor to perform work pursuant to the contract with the City.
3. If the Vendor becomes the successful Contractor who enters into a contract with the City, then the Vendor will comply with the requirements of Section 448.095, Fla. Stat. "Employment Eligibility", as amended from time to time.
4. Vendor will obtain an affidavit from all subcontractors attesting that the subcontractor does not employ, contract with, or subcontract with, an unauthorized alien as defined in 8 United States Code, Section 1324A(H)(3).
5. Vendor will maintain the original affidavit of all subcontractors for the duration of the contract.
6. Vendor affirms that failure to comply with the state law requirements can result in the City's termination of the contract and other penalties as provided by law.

VENDOR: \_\_\_\_\_ (Vendor's Company Name)  
 \_\_\_\_\_ (Vendor signature)  
 \_\_\_\_\_ (Vendor's name printed)  
 \_\_\_\_\_ (Title)

Sworn to and subscribed before me by means of  physical presence or  online notarization, this \_\_\_\_ day of \_\_\_\_\_, 2022, by \_\_\_\_\_, as \_\_\_\_\_.

\_\_\_\_\_  
Notary Public

Personally Known \_\_\_\_\_ OR Produced Identification \_\_\_\_\_  
Type of Identification Produced \_\_\_\_\_

**THIS PAGE MUST BE COMPLETED AND SUBMITTED**

**ATTACHMENT 17:  
CITY OF NORTH PORT  
BID BOND**

In Compliance with F.S. Chapter 255.051

STATE OF FLORIDA, CITY OF NORTH PORT

KNOW ALL BY THESE PRESENTS, that \_\_\_\_\_, authorized by law to do business as a \_\_\_\_\_ Contractor in the State of Florida, as Principal, and \_\_\_\_\_, a Corporation chartered and existing under the laws of the State of \_\_\_\_\_, as Surety, with its principal offices in the City of \_\_\_\_\_, and authorized to do business in the State of Florida, and in accordance with Section 255.051, Florida Statutes, are held and firmly bound unto the City of North Port, Florida, in the full and just sum of 5% of the Total Bid Price, in good and lawful money of the United States of America, to be paid upon demand by the City of North Port, to which payment well and truly to be made, we bind ourselves, our heirs, executors, administrators, and assigns, joint and severally and firmly by these presents.

The condition of the obligation is such, that whereas the Principal has submitted the attached Bid, dated \_\_\_\_\_, for **RENOVATION OF LIFT STATIONS 29, 45 AND 73, RFB 2023-04**.

NOW, THEREFORE, if the Principal shall withdraw said bid prior to the date of opening the same, or shall within 10 days after the prescribed forms are presented to him for signature enter into a written Contract with City of North Port, Florida, in accordance with the bid as accepted and give a Performance and Payment Bond with good and sufficient surety or sureties as may be required for the faithful performance and proper fulfillment of such Contract and for the prompt payment of all persons furnishing labor or materials in connection therewith or, in the event of failure to enter into such Contract and give such bond within the time specified, if the Principal shall pay the City the difference between the amount specified in said bid and the amount for which the City may procure the required work and/or supplies provided the latter amount to be excess of the amount specified in said bid, then the above obligations shall be void: otherwise, to remain in full force and effect.

IN THE WITNESS WHEREOF, the above written parties have executed this instrument under their several seals dated \_\_\_\_\_, the name and corporate seal of each corporate party being hereto affixed and these presents duly signed by its undersigned representative, pursuant to authority of its governing body.

Witness as to Principal:

\_\_\_\_\_ (SEAL)

(Principal)

(By)

Witness as to Surety:

\_\_\_\_\_  
Printed Name

\_\_\_\_\_ (SEAL)

(Surety's Name)

\_\_\_\_\_  
(By-As Attorney-in-Fact, Surety)

Affix Corporate Seals and attach proper Power of Attorney for Surety.

**THIS PAGE MUST BE COMPLETED AND SUBMITTED**



**ATTACHMENT 18:**

**CITY OF NORTH PORT**

**PERFORMANCE AND PAYMENT BOND**

In compliance with F.S. Chapter 255.05(10(a) and Code of the City of North Port Sec. 2-414

**BOND NO.:**

**BOND AMOUNT:**

\_\_\_\_\_

**CONTRACTOR NAME:**

**PRINCIPAL ADDRESS:**

**PRINCIPAL PHONE NO.:**

\_\_\_\_\_

\_\_\_\_\_

\_\_\_\_\_

**SURETY COMPANY NAME:**

**SURETY AGENT:**

**PRINCIPAL ADDRESS:**

**PRINCIPAL PHONE NO.:**

\_\_\_\_\_

\_\_\_\_\_

\_\_\_\_\_

\_\_\_\_\_

**CITY NAME:**

**PRINCIPAL ADDRESS:**

**CITY CONTACT PHONE NO.:**

City of North Port, Florida

4970 City Hall Boulevard

North Port, Florida 34288

(941) 628-3621

**CONTRACT NO.: (if applicable)**

**PROJECT ADDRESS:**

**(if applicable)**

2023-04

5655 North Port Blvd

North Port, Florida 34287

**DESCRIPTION OF PROJECT:**

**(if applicable)**

**RENOVATION OF LIFT STATIONS 29, 45 AND 73**

**DESCRIPTION OF**

**IMPROVEMENT:**

\_\_\_\_\_

\_\_\_\_\_

\_\_\_\_\_

\_\_\_\_\_

\_\_\_\_\_

\_\_\_\_\_

\_\_\_\_\_

\_\_\_\_\_

\_\_\_\_\_

**RFB No. 2023-04 RENOVATION OF LIFT STATIONS 29, 45 AND 73**

\_\_\_\_\_  
\_\_\_\_\_  
\_\_\_\_\_

**By this Bond**, we, \_\_\_\_\_, as Principal, hereinafter called Contractor, and \_\_\_\_\_, a corporation organized and existing under the laws of the State of \_\_\_\_\_, with its principal office in the City of \_\_\_\_\_, as Surety, hereinafter called Surety, are held firmly bound unto the City of North Port, Florida, as Obligee, hereinafter called City, in the amount of \_\_\_\_\_ Dollars (\$ \_\_\_\_\_), for the payment whereof Contractor and Surety bind themselves, their heirs, executors, administrators, personal representatives, successors, and assigns, jointly and severally, firmly by these presents.

**WHEREAS**, Contractor has by written agreement dated \_\_\_\_\_, entered into a Contract with City for \_\_\_\_\_

\_\_\_\_\_  
\_\_\_\_\_

In accordance with drawings and specifications prepared by \_\_\_\_\_

\_\_\_\_\_

Which Contract is by reference made a part hereof, and is hereinafter referred to as the CONTRACT.

NOW, THEREFORE, THE CONDITION OF THIS BOND is such that if Contractor:

1. Performs the Contract dated \_\_\_\_\_, between Contractor and City for construction for the **RFB NO. 2023-04 RENOVATION OF LIFT STATIONS 29, 45 AND 73**, the Contract being made a part of this bond by reference, at the times and in the manner prescribed in the Contract: and
2. Promptly makes payments to all claimants, as defined in Section 255.05(1), Florida Statutes, supplying Contractor with labor, materials, or supplies, used directly or indirectly by Contractor in the prosecution of the work provided for in the Contract: and
3. Pays City all losses, damages, expenses, costs, and attorney’s fees, including appellate proceedings, that City sustains because of a default by Contractor under the Contract: and
4. Performs the guarantee of all work and materials furnished under the Contract for the time specified in the Contract, then this bond is void: otherwise it remains in full force.

Any action instituted by City under this bond for payment must be in accordance with the notice and time limitation provisions in Section 255.05(2), Florida Statutes.

Any changes in or under the Contract documents and compliance or noncompliance with any formalities connected with the Contract or the changes does not affect Surety’s obligation under this bond.

In witness whereof, the said Contractor and Surety have signed and sealed this instrument

**RFB No. 2023-04 RENOVATION OF LIFT STATIONS 29, 45 AND 73**

this \_\_\_\_\_  
(date)

\_\_\_\_\_  
Principal

By:

\_\_\_\_\_  
As President

(SEAL)

\_\_\_\_\_  
Surety

By:

Any Claims under this bond may be addressed to  
(name and address of Surety):

\_\_\_\_\_  
\_\_\_\_\_  
\_\_\_\_\_

Telephone No: \_\_\_\_\_

Name and address of agent or representative in Florida if different from above:

\_\_\_\_\_  
\_\_\_\_\_  
\_\_\_\_\_

Telephone No: \_\_\_\_\_

**THIS FORM TO BE UTILIZED BY THE AWARDED VENDOR ONLY**

**“SAMPLE”**

**CONTRACT (SUBJECT TO CHANGE)**

This **Contract No. 2023-04** (“Contract”), is entered into by and between the City of North Port, Florida, a municipal corporation of the State of Florida, hereinafter referred to as the “City,” and XYZ, Inc., a Florida corporation, registered to do business in the State of Florida, whose principal place of business is ADDRESS, Florida 32771, hereinafter referred to as the “Contractor.” This project has Community Block Development Grant funds associated with it.

**WITNESSETH**

That the parties to this Contract, for and in consideration of the mutual covenants specified herein and for other good and valuable consideration, the sufficiency and receipt of which are hereby acknowledged, the Parties agree as follows:

**1. RESPONSIBILITIES OF THE CONTRACTOR:**

A. Responsibility for Supervision:

1. The Contractor must supervise and direct all work performed pursuant to this Contract to the best of its ability, give it all the attention necessary for such proper supervision and direction, and not employ for work on the project any person without sufficient skill to perform the job for which the person is employed.
2. The Contractor assumes full responsibility for any and all acts, negligence, or omissions of its employees, for those subcontractors and their employees, and for those of all other persons doing work under a contract with Contractor in furtherance of this Contract. All contracts between the Contractor and any such subcontractor as the Contractor shall hire, must conform to the provisions of this Contract and the Request for Bid No. 2023-XX (“RFB”) documents and the Community Development Block Grant Special Conditions, and must incorporate in them the relevant portions of this Contract. The Community Development Block Grant Special Conditions are attached to this Contract as Exhibit “A” and incorporated as if set forth fully herein.

B. Furnishing of Labor and Materials:

1. The Contractor must provide and pay for all labor, materials, and equipment, including tools, construction equipment, and machinery, all transportation and all other facilities and services necessary for the proper completion of the work to be performed in furtherance of this Contract in strict conformity with the provisions herein contained, the RFB plans, drawings, specifications, addenda and the related proposal submitted by the Contractor and on file with the City.
2. The Contractor represents and warrants to the City that all equipment and materials used in such work, and made a part of the structures thereon, or placed permanently in connection therewith, will be new unless otherwise specified in this Contract or related bid documents, will be of good quality, free of defects, and in conformity with this Contract and related bid documents. It is understood between the parties thereto that all equipment and materials not in conformity are defective.

C. Scope and Incorporation of Bid Documents: The work includes the construction of sidewalks in the Price Boulevard Area as described in the RFB, including plans and/or drawings, specifications, and addenda, and the Contractor’s

**RFB No. 2023-04 RENOVATION OF LIFT STATIONS 29, 45 AND 73**

response to the RFB, are specifically made a part of this Contract and are incorporated herein by reference. In the event of a conflict between or among the documents or any ambiguity or missing specifications or instruction, the following priority is established:

1. This Contract (Contract No. 2023-XX) approved by the City Commission, and any attachments thereto.
2. The RFB, including any and all attachments and addenda including the Community Development Block Grant Special Provisions..
3. Contractor's response to the solicitation.
4. Specific direction from the City Manager.

D. Public Records Law: In accordance with Florida Statutes Section 119.0701, Contractor must comply with all public records laws, and shall specifically:

1. Keep and maintain public records required by the City to perform the service.
  - a. The timeframes and classifications for records retention requirements must be in accordance with the General Records Schedule GS1-SL for State and Local Government Agencies.  
(See <http://dos.state.fl.us/library-archives/records-management/general-records-schedules/>)
  - b. "Public records" means and includes those items specified in Florida Statutes Section 119.011(12), as amended from time to time, and currently defined as: All documents, papers, letters, maps, books, tapes, photographs, films, sound recordings, data processing software, or other material, regardless of the physical form, characteristics, or means of transmission, made or received pursuant to law or ordinance or in connection with the transaction of official business with the City. Contractor's records under this Contract include but are not limited to, supplier/subcontractor invoices and contracts, project documents, meeting notes, e-mails and all other documentation generated during the term and in furtherance of this Contract.
2. Upon request from the City's custodian of public records, provide the City, at no cost, with a copy of the requested records or allow the records to be inspected or copied within a reasonable time at a cost that does not exceed the cost provided for by law. All records kept electronically must be provided to the City, upon request from the City's custodian of public records, in a format that is compatible with the information technology systems of the City.
3. Ensure that project records that are exempt or confidential and exempt from public records disclosure requirements are not disclosed except as authorized by law for the duration of the Contract term and, if the Contractor does not transfer the records to City following completion of the Contract, for the time period specified in General Records Schedule GS1-SL for State and Local Government Agencies.
4. Upon completion of the Contract, transfer, at no cost, to the City all public records in Contractor's possession or keep and maintain public records required by the City to perform the service. If the Contractor transfers all public records to the City upon completion of the Contract, the Contractor shall destroy any duplicate public records that are exempt or confidential and exempt from public records disclosure requirements. If the Contractor keeps and maintains public records upon the completion of the Contract, the Contractor shall meet all applicable requirements for retaining public records.

5. **IF THE CONTRACTOR HAS QUESTIONS REGARDING THE APPLICATION OF CHAPTER 119, FLORIDA STATUTES, TO THE CONTRACTOR'S DUTY TO PROVIDE PUBLIC RECORDS RELATING TO THIS CONTRACT, CONTACT THE CUSTODIAN OF PUBLIC RECORDS AT CUSTODIAN OF PUBLIC RECORDS, 4970 CITY HALL BOULEVARD, NORTH PORT, FLORIDA 34286, 941.429.7063 OR HOTLINE 941.429.7270; E-MAIL: [publicrecordsrequest@cityofnorthport.com](mailto:publicrecordsrequest@cityofnorthport.com).**
6. Failure of the Contractor to comply with these requirements shall be a material breach of this Contract. Further, Contractor may be subject to penalties under Florida Statutes Section 119.10.

**2. CONTRACT PRICE:**

- A. In consideration of the foregoing services, work, labor, and materials to be furnished by the Contractor as per said plans, specifications, and addendums, the City agrees to pay, and the Contractor agrees to receive payments in accordance with the prices set forth in the RFB as amended from time to time to account for actual field conditions.
- B. The Contract price is **Dollars and Cents (\$XX,XXX)**.

**3. PAYMENT:**

- A. One (1) original request for payment must be submitted to the City on a City approved form. Each pay request must be accompanied by an updated work schedule to reflect the progress of all work. Payment must be accompanied by either written approval and direction of the surety, or receipt of updated affidavits of payment by subcontractors and/or suppliers, in accordance with Florida Statutes Section 255.05(11).
- B. Contract price is net, and all invoices will be payable according to the Florida Local Government Prompt Payment Act (Florida Statutes Section 218.70, *et seq.*). Upon certification and approval by the City or its duly authorized agent, progress payments may be made to the Contractor upon its application for all services or work completed or materials furnished in accordance with this Contract.
- C. The Contractor will be paid monthly the total value of the work completed and accepted during the preceding month, less five percent (5%) retainage. The City must inform the Contractor's Surety of any reduction in retainage.
- D. Contractor must update each new pay request in accordance with any changes made to the previous submittal. City approval is required before making final payment for all work, materials, or services furnished under this Contract. Retainage may be reduced upon issuance of the Certificate of Substantial Completion by the City if, in the sole opinion of the City, sufficient progress on the schedule has been accomplished, all required affidavits have been provided, and the City has retained adequate coverage for the project through the achievement of Final Completion.

**4. CONTRACT TIME:**

- A. This Contract shall be effective on the date the last party signs it (the "Effective Date"), and shall terminate upon the completion of the work or as otherwise detailed herein.
- B. Following the Effective Date of this Contract, the Contractor specifically agrees that it will commence operations within a mutually agreed upon time following notification by the City to commence work ("notice to proceed"),

**RFB No. 2023-04 RENOVATION OF LIFT STATIONS 29, 45 AND 73**

and that all work performed under the provisions of this Contract must be completed in not more than 210 **calendar days** from the notice to proceed; subject only to delays caused through no fault of the Contractor or acts of God. The work must be substantially completed within 180 **calendar days** from the notice to proceed, with final completion within **thirty (30) calendar days** after attaining Substantial Completion. Time is of the essence in the performance of this Contract.

- C. Mobile fire training unit shall be delivered to the City within one hundred and eighty (180) calendar days after receipt of order. This timeline shall also include approval by the City of vendor shop drawings. All orders shall be delivered to the address located in the City limits as further specified.

**5. LIQUIDATED DAMAGES:**

- A. The work performed pursuant to this Contract must be completed within the times specified herein. The Contract time includes the preparation, submittal, review, and approval of submittals, delivery of materials, and construction, assembly, adjustment, and placement into service for beneficial use of all facilities covered under this Contract.
- B. The City must issue a Notice of Substantial Completion when it has determined that the work identified in this Contract is substantially complete, record drawings are submitted and approved by the City, and that the facility is operating satisfactorily. The City requires not less than **fourteen (14)** calendar days for the review of the work, and the submittals, excluding pay requests. The Contractor must respond within two (2) business days after receipt of any questions from the City, regarding the identified work for the project, the record drawings, and other submittals. The City reserves the right to require Contractor's resubmission of record drawings and other submittals to conform to the work identified in the project. The City must provide the Contractor a punch list within **two (2)** business days after the Notice of Substantial Completion is issued. The punch list must identify the remaining items to be addressed to the satisfaction of the City and in order for the Contractor to meet its obligations under this Contract. The Contractor must complete the items on the punch list to the satisfaction of the City within thirty (30) calendar days following the issuance of the Final Punch List or Notice of Substantial Completion, whichever is later, and prior to submittal of the application for reduction of retainage or final payment. Any cost incurred by the City (i.e. inspection time) after the thirty (30) calendar day period must be charged to the Contractor.
- C. The City and the Contractor hereby agree that time is of the essence on this Contract and the City will suffer damages if the work is not substantially completed within the Contract time, plus any extensions thereof allowed by Change Order. It is further recognized and agreed by the City and the Contractor that the determination of the exact value of the damages the City would suffer due to a delay in the Substantial Completion of the work would be a difficult, time consuming, and a costly process. It is therefore hereby agreed by the City and the Contractor that it is in their mutual interest to establish a figure of **Four Hundred and Ninety-Four Dollars and Zero Cents (\$494.00)** as Liquidated Damages (but not as a penalty) to be paid by the Contractor to the City for each calendar day that Substantial Completion is delayed beyond the Contract Time.
- D. It is mutually agreed by the City and the Contractor that neither will make any claim to increase or reduce the amount to be paid under Liquidated Damages as the result of any calculation of actual damages suffered by the City as the result of delay in the Substantial Completion of the work.

**6. BOND REQUIREMENTS:**

- A. Bond Requirements:

**RFB No. 2023-04 RENOVATION OF LIFT STATIONS 29, 45 AND 73**

1. The successful bidder must provide the required performance and payment bond or other acceptable security to the City within **ten (10)** business days of being awarded the bid. Failure by the successful bidder to provide the bond within **ten (10)** business days shall be considered a default under Section 2-404 of the Code of City of North Port, Florida. Upon such default the City may immediately award the bid to the next lowest responsive and responsible bidder and recover from the original successful bidder the difference in cost between the original winning bid and the next lowest responsive and responsible bidder. Such default is only curable at the option of the City.
  2. In addition, the Contractor is responsible and bears all cost associated with recording the Performance and Payment Bond with the Sarasota County Clerk's Office. The Contractor must furnish the receipt of said recording and certified copy of the bond to the Purchasing Department at the time of the pre-construction meeting. Such default is only curable at the option of the City.
- B. Performance and Payment Bond: The Contractor must provide a Performance and Payment Bond, in the form prescribed in Florida Statutes Section 255.05, in the amount of one hundred percent (100%) of the Contract amount, the costs of which are to be paid by the Contractor. The bond will be acceptable to the City only if the Surety Company:
1. Is licensed to do business in the State of Florida;
  2. Holds a certificate of authority authorizing it to write surety bonds in the State of Florida;
  3. Has twice the minimum surplus and capital required by the Florida Insurance Code at the time the invitation to bid is issued;
  4. Is otherwise in compliance with the provisions of the Florida Insurance Code;
  5. Holds a currently valid certificate of authority issued by the United States Department of Treasury under 31 U.S.C. §§ 9304-9308;
  6. Has a current rating of at least Excellent (A or A-) as reported in the most current Best Key Rating Guide, published by A.M. Best Company, Inc., of 75 Fulton Street, New York, New York 10038; and
  7. Has an underwriting limitation of at least two times the dollar amount of this Contract.
- C. If the Surety Company for any bond furnished by the Contractor files for bankruptcy, has a receiver appointed, is declared bankrupt, becomes insolvent, has an assignment made for the benefit of creditors, has its right to do business terminated in the State of Florida, or ceases to meet the requirements imposed by the Contract Documents, the Contractor must, within **five (5)** calendar days thereafter, substitute another Bond and Surety Company, both of which are subject to the City's approval.
- D. By execution of the bond, the Surety Company acknowledges that it has read the surety qualifications and surety obligations imposed by the Contract Documents and satisfies all conditions.
- 7. CONTRACTOR'S INSURANCE:**
- A. Insurance:
1. Before performing any work pursuant to this Contract, the Contractor must procure and maintain, during the life of this Contract, the insurance listed below against all claims of injury to persons or damage to property



**RFB No. 2023-04 RENOVATION OF LIFT STATIONS 29, 45 AND 73**

which may arise from or in connection with its performance of the work hereunder, unless otherwise specified. The policies of insurance must be primary and written on forms acceptable to the City and placed with insurance carriers approved and licensed by the Insurance Department in the State of Florida and meet a minimum financial AM Best and Company rating of no less than "A - Excellent: FSC VII." No changes can be made to these specifications without prior written approval by the City Manager or designee. The City Manager or designee may alter the amounts or types of insurance policies required by this Contract upon agreement with the Contractor. The insurance policies must remain in place until all of the Contractor's and subcontractor's obligations and warranty periods in place pursuant to this Contract have been discharged or satisfied.

2. The below insurance requirements are minimum requirements for this Contract and in no way limit the indemnity covenants contained in this Contract. The City in no way warrants that the minimum limits contained herein are sufficient to protect the Contractor from liabilities that might arise out of the performance of the work done pursuant to this Contract by the Contractor, its agents, representatives, employees, or subcontractors. Contractor is free to purchase such additional insurance as it may determine necessary. The extent of Contractor's liability for indemnity of the City shall not be limited by insurance coverage or lack thereof, or unreasonably delayed for any reason, including but not limited to, insurance coverage disputes between the Contractor and its carrier.

B. Workers' Compensation and Employers' Liability Insurance (Per Chapter 440, Florida Statutes): Coverage must apply to all employees at the statutory limits provided by state and federal laws. The policy must include Employers' Liability with a limit of \$1,000,000 for each accident; \$1,000,000 each employee; and \$1,000,000 policy limit for bodily injury or disease. Proof of such insurance must be filed by the Contractor with the City within **ten (10)** days after the Effective Date of this Contract.

C. Comprehensive Commercial General Liability Insurance: Coverage must apply to all employees at the statutory limits provided by state and federal laws. The Contractor must procure and maintain, and require all subcontractors to procure and maintain, during the life of this Contract, a comprehensive commercial general liability policy, including but not limited to bodily injury, property damage, broad form contractual liability and Explosion, Collapse and Underground (XCU) coverage. The general aggregate limit must apply separately to this Contract or the general aggregate limit shall be twice the required occurrence limit.

The policy must include General Liability with a limit of \$1,000,000 for General Aggregate; \$1,000,000 for each occurrence; \$1,000,000 for Products and Completed Operations; \$100,000 for damage to rented premises; and \$100,000 for Fire Damage. Proof of such insurance must be filed by the Contractor with the City within **ten (10)** days after the Effective Date of this Contract.

D. Automobile Liability Insurance: The Contractor must procure and maintain, and require all subcontractors to procure and maintain, during the life of this Contract, automobile liability insurance to include all owned, leased, hired, and non-owned vehicles. Automobile liability insurance must be written on a standard ISO form (CA 00 01) covering any auto (Code 1), or if Contractor has no owned autos, hired (Code 8) and non-owned (Code 9) autos.

## RFB No. 2023-04 RENOVATION OF LIFT STATIONS 29, 45 AND 73

The policy must include liability insurance with a limit of \$1,000,000 for Combined Single Limit (CSL) for each accident; \$1,000,000 per person for Bodily Injury; \$1,000,000 per accident for Bodily Injury; and \$1,000,000 per accident for Property Damage. Proof of such insurance must be filed by the Contractor with the City within **ten (10)** days after the Effective Date of this Contract.

- E. Waiver of Subrogation: All required insurance policies, with the exception of Workers' Compensation, are to be endorsed with a Waiver of Subrogation. The insurance companies, by proper endorsement or through other means, must agree to waive all rights of subrogation against the City, its Commissioners, officers, officials, employees, volunteers, and the City's insurance carriers, for losses paid under the terms of these policies that arise from the contractual relationship or work performed by the Contractor for the City. It is the Contractor's responsibility to notify its insurance company of the Waiver of Subrogation and request written authorization or the proper endorsement. Additionally, the Contractor, its officers, officials, agents, employees, volunteers, and any subcontractors, agree to waive all rights of subrogation against the City and its insurance carriers for any losses paid, sustained, or incurred, but not covered by insurance, that arise from the contractual relationship or work performed. This waiver applies to any deductibles or self-insured retentions for which the Contractor or its agents may be responsible.

F. Policy Form:

1. All policies required by this Contract, with the exception of Workers' Compensation, or unless specific approval is given by Risk Management through the City's Purchasing Office, are to be written on an occurrence basis, and must name the City of North Port, Florida, its Commissioners, officers, agents, employees, and volunteers as additional insured as their interest may appear under this Contract. Claims Made Policies will be accepted for professional liability and hazardous materials and such other risks as are authorized by the City's Purchasing Office. All Claims Made Policies contributing to the satisfaction of the insurance requirements herein must have an extended reporting period option or automatic coverage of not less than two (2) years. If provided as an option, Contractor must purchase the extended reporting period on cancellation or termination unless a new policy is affected with a retroactive date, including at least the last policy year.
2. Insurance requirements itemized in this Contract, and required of the Contractor, must be provided by or on behalf of all subcontractors to cover their operations performed under this Contract. The Contractor is responsible for any modifications, deviations, or omissions in these insurance requirements as they apply to its subcontractors.
3. Each insurance policy required by this Contract must:
  - a. Apply separately to each insured against whom claim is made and suit is brought, except with respect to limits of the insurer's liability.
  - b. Be endorsed to state that coverage must not be suspended, voided, or cancelled by either party except after notice is delivered in accordance with the policy provisions. The Contractor is to notify the City's Purchasing Office of such an occurrence by written notice via certified mail, return receipt requested.
4. The City retains the right to review, at any time, coverage, form, and amount of insurance.
5. The Contractor is solely responsible for payment of all premiums for insurance contributing to the satisfaction of this Contract and is solely responsible for the payment of all deductibles, SIR (self-insured retentions), any loss or portion of any loss that is not covered by any available insurance policy, and retention

**RFB No. 2023-04 RENOVATION OF LIFT STATIONS 29, 45 AND 73**

to which such policies are subject, whether or not the City is an insured under the policy. Contractor's insurance is considered primary for any loss, regardless of any insurance maintained by the City.

6. All certificates of insurance must be on file with and approved by the City before commencement of any work done pursuant to this Contract. All certificates of insurance required herein must be accompanied by a copy of the additionally insured documents/endorsements (CG 20101185 or combination of CG 2010370704 and CG 20370704). Certificates of Insurance evidencing Claims Made or Occurrences form coverage and conditions to this Contract, as well as the contract number and description of work, are to be furnished to the City's Purchasing Office (4970 City Hall Boulevard, Suite 337, North Port, FL 34286) prior to commencement of the work AND a minimum of **thirty (30)** calendar days prior to expiration of the insurance contract when applicable. All insurance certificates must be received by the City's Purchasing Office before the Contractor will be allowed to commence or continue work. The Certificate of Insurance issued by the underwriting department of the insurance carrier must certify compliance with the insurance requirements provided herein.

7. Notices of Accidents (Occurrences) and Notices of Claims associated with work being performed pursuant to this Contract must be provided to Contractor's insurer(s) and the City's Purchasing Office as soon as practicable after notice to the insured Contractor.

**8. INDEMNITY:**

- A. TO THE EXTENT PERMITTED BY FLORIDA LAW, THE CONTRACTOR SHALL INDEMNIFY, DEFEND, AND HOLD HARMLESS THE CITY, ITS COMMISSIONERS, OFFICERS, AGENTS AND EMPLOYEES, FROM ALL LIABILITIES, FINES, CLAIMS, ASSESSMENTS, SUITS, JUDGMENTS, DAMAGES, LOSSES AND COSTS, INCLUDING CONSEQUENTIAL, SPECIAL, INDIRECT, AND PUNITIVE DAMAGES, (INCLUDING, BUT NOT LIMITED TO, REASONABLE ATTORNEYS' FEES AND COURT COSTS, WHETHER SUCH FEES AND COSTS ARE INCURRED IN NEGOTIATIONS, AT THE TRIAL LEVEL OR ON APPEAL, OR IN THE COLLECTION OF ATTORNEYS' FEES), ARISING OUT OF ANY ACTS, ACTIONS, BREACHES, NEGLIGENCE ACTS OR OMISSIONS OF THE CONTRACTOR, OR CONTRACTOR'S OFFICERS, EMPLOYEES, AGENTS, SUB-CONTRACTORS, SUB-CONSULTANTS, AND OTHER PERSONS EMPLOYED OR UTILIZED BY THE CONTRACTOR IN THE PERFORMANCE OF, OR THE FAILURE TO PERFORM, THE CONTRACT. THE CONTRACT DOES NOT CONSTITUTE A WAIVER OF SOVEREIGN IMMUNITY OR CONSENT BY THE CITY OR ITS SUBDIVISIONS TO SUIT BY THIRD PARTIES.**
- B. THE CITY MUST PROVIDE ALL AVAILABLE INFORMATION AND ASSISTANCE THAT THE CONTRACTOR MAY REASONABLY REQUIRE REGARDING ANY CLAIM. IN THE EVENT OF A CLAIM, THE CITY MUST PROMPTLY NOTIFY THE CONTRACTOR IN WRITING BY PREPAID CERTIFIED MAIL (RETURN RECEIPT REQUESTED) OR BY DELIVERY THROUGH ANY NATIONALLY RECOGNIZED COURIER SERVICE (SUCH AS FEDERAL EXPRESS OR UPS) WHICH PROVIDES EVIDENCE OF DELIVERY, AT THE ADDRESS PROVIDED FOR RECEIPT OF NOTICES IN THIS CONTRACT.**
- C. THIS AGREEMENT FOR INDEMNIFICATION SHALL SURVIVE TERMINATION OR COMPLETION OF THE CONTRACT. THE INSURANCE COVERAGE AND LIMITS REQUIRED IN THIS CONTRACT MAY OR MAY NOT BE ADEQUATE TO PROTECT THE CITY AND SUCH INSURANCE COVERAGE WILL NOT BE DEEMED A LIMITATION ON THE CONTRACTOR'S LIABILITY UNDER THE INDEMNITY PROVIDED IN THIS SECTION. IN ANY PROCEEDINGS BETWEEN THE PARTIES ARISING OUT OF OR RELATED TO THIS INDEMNITY PROVISION, THE PREVAILING PARTY SHALL BE REIMBURSED ALL COSTS, EXPENSES AND REASONABLE ATTORNEY FEES THROUGH ALL PROCEEDINGS (AT BOTH TRIAL AND APPELLATE LEVELS).**
- D. NOTHING IN THIS CONTRACT SHALL BE DEEMED TO AFFECT THE RIGHTS, PRIVILEGES AND IMMUNITIES OF THE CITY AS SET FORTH IN FLORIDA STATUTES SECTION 768.28.**

**E. THE TERMS OF THIS SECTION SURVIVE THE TERMINATION OF THIS CONTRACT.**

**F. FURTHER, THE CONTRACTOR SHALL FULLY INDEMNIFY, DEFEND, AND HOLD HARMLESS THE CITY OF NORTH PORT, FLORIDA, FROM ANY SUITS, ACTIONS, DAMAGES, AND COSTS OF EVERY NAME AND DESCRIPTION, INCLUDING ATTORNEYS' FEES, ARISING FROM OR RELATING TO VIOLATION OR INFRINGEMENT OF A TRADEMARK, COPYRIGHT, PATENT, TRADE SECRET OR INTELLECTUAL PROPERTY RIGHT.**

**9. CONTRACTOR'S AFFIDAVIT:** When all work contemplated by this Contract has been completed and has been inspected and approved by the City or its duly authorized agent, the Contractor must furnish to the City, a Contractor's Affidavit in a form acceptable to the City. Signed affidavits of payment are required from any and all subcontractors hired by the Contractor, unless payment is approved by the surety in accordance with Florida Statutes Section 255.05(11). The affidavits must state whether the subcontractor(s) has been paid in full or whether there are payments remaining. A list of all subcontractors must be furnished to the City prior to any payments against the Contract.

**10. TERMINATION:**

A. Termination with or without Cause: The performance of work under this Contract may be terminated with or without cause by the City Manager, in whole or in part, whenever the City Manager determines that termination is in the City's best interest. Any such termination shall be effective by delivery to the Contractor of a written notice of termination at least thirty (30) calendar days before the date of termination, specifying the extent to which performance of the work is terminated and the date upon which such termination becomes effective. Except as otherwise directed, the Contractor shall cease all work on the date of receipt of the notice of termination or other date specified in the notice; place no further orders or subcontracts for material, services, or facilities except as necessary for completion of such portion of the work not terminated; terminate all vendors and subcontracts; and settle all outstanding liabilities and claims. Contractor must deliver to the City all documents (including but not limited to reports, designs, specifications, and all other data) prepared or obtained by the Contractor in connection with its services. Upon delivery of the documents, the City shall pay the Contractor in full settlement of all claims by it hereunder as the work actually completed bears to the entire work under the Contract, as determined by the City, less payments already made to the Contractor, and any amounts withheld by the City to settle claims against or to pay indebtedness of the Contractor in accordance with the provisions of the Contract. Under no circumstances shall the City make any payment to Contractor for services that have not been performed or that are performed subsequent to the termination date.

B. Non-Appropriation: The parties acknowledge and agree that the obligations of the City to fulfill financial obligations of any kind pursuant to any and all provisions of this Contract, or any subsequent contract entered into pursuant to this Contract, or referenced herein to which City is a party, are and shall remain subject to the provisions of Florida Statutes Section 166.241, regardless of whether a particular obligation has been expressly so conditioned. The City agrees to exercise all lawful and available authority to satisfy any financial obligations of City that may arise under this Contract; however, since funds are appropriated annually by the City Commission on a fiscal year basis, City's legal liability for the payment of any costs shall not arise unless and until appropriations for such costs are approved for the applicable fiscal year by the City Commission (nor shall such liability arise if, a request for such appropriations is excluded from the budget approved by the City Commission). Notwithstanding the foregoing, no Commissioner, officer, employee, director, member or other natural person or agent of City shall have any personal liability in connection with a breach of the provisions of this Section or in the event of a default by City under this Section. This Contract shall not constitute an indebtedness of City nor shall it constitute an obligation for which City is obligated to levy or pledge any form of taxation or for which City has levied or

**RFB No. 2023-04 RENOVATION OF LIFT STATIONS 29, 45 AND 73**

pledged any form of taxation. It is expressly understood by the parties that funding for any subsequent fiscal year of the Contract is contingent upon appropriation of monies by the City Commission. In the event that funds are not available or appropriated, the City reserves the right to terminate the Contract. The City will be responsible for payment of any outstanding invoices and work completed by the Contractor prior to such termination.

- C. Abandonment: In the event that the Contractor abandons performance under this Contract, the City Manager or designee may terminate this Contract upon three (3) calendar days' written notice to the Contractor indicating the intention to do so. The written notice must state the evidence indicating the Contractor's abandonment.
- D. Contractor's termination. The Contractor may terminate this Contract only in the event of the City failing to pay the Contractor's properly documented and submitted invoice within ninety (90) calendar days of the approval by the City's Administrative Agent, or if the project is suspended by the City for a period greater than ninety (90) calendar days.
- E. Court proceedings. The City Manager or designee reserves the right to terminate this Contract in the event the Contractor is placed in either voluntary or involuntary bankruptcy, a receiver is appointed for the Contractor, or an assignment is made for the benefit of creditors.
- F. Breach: In the event Contractor is in breach of this Contract, the City must provide written notice of the breach and Contractor shall have ten (10) calendar days from the date the notice is received to cure. If the Contractor fails to cure within the ten (10) calendar days, the City Manager or designee can immediately terminate the Contract and/or refuse to make any additional payment, in whole or in part, and if necessary, may demand the return of a portion or the entire amount previously paid to Contractor due to:
  - 1. The quality of a portion or all of the Contractor's work not being in accordance with the requirements of this Contract;
  - 2. The quantity of the Contractor's work not being as represented in the Contractor's Payment Request, or otherwise;
  - 3. The Contractor's rate of progress being such that, in the City's opinion, substantial or final completion, or both, may be inexcusably delayed;
  - 4. The Contractor's failure to use Contract funds, previously paid the Contractor by the City, to pay Contractor's project related obligations including, but not limited to, subcontractors, laborers and material and equipment suppliers;
  - 5. Claims made, or likely to be made, against the City or its property;
  - 6. Loss caused by the Contractor;
  - 7. The Contractor's failure or refusal to perform any of the obligations to the City, after written notice and a reasonable opportunity to cure as set forth above; or
  - 8. Violation of any local, state, or federal law in the performance of this Contract which will constitute a material breach of this Contract.
- G. Payment adjustments. In the event that the City makes written demand upon the Contractor for amounts previously paid by the City as contemplated in this Section, the Contractor must promptly comply with such demand. The City's rights hereunder survive the term of this Contract and are not waived by final payment and/or acceptance.

- H. E-Verify Violation: If the City has a good faith belief that the Contractor has knowingly violated Section 448.095(2), Fla. Stat., then the Contract may be terminated by the City. If the City that has a good faith belief that a subcontractor has knowingly violated Section 448.095(2), Fla. Stat., but the contractor otherwise complied, then the City will promptly notify the contractor and order the contractor to immediately terminate the contract with the subcontractor. Any challenge to termination of this Contract under this provision must be filed in the Circuit Court no later than 20 calendar days after the date of termination. If this Contract is terminated for a violation of the statute by the Contractor, the Contractor may not be awarded a public contract for a period of one year after the date of termination and will be liable for any additional costs incurred by the City as a result of the termination of this Contract.
- I. Remedies: In the event of a default or breach of the contract terms, the City may avail itself of each and every remedy specifically given to it now existing at law or in equity, and each and every such remedy will be in addition to every other remedy so specifically given or otherwise so existing and may be exercised from time to time and as often and in such order as may be deemed expedient by the City. The exercise, or the beginning of the exercise, of one remedy will not be deemed to be a waiver of the right to exercise, at the same time or thereafter, any other remedy. The City's rights and remedies as set forth in this Agreement are not exclusive and are in addition to any other rights and remedies available to it in law or in equity.
- 11. INDEPENDENT CONTRACTOR:** The Contractor is, and shall be, in the performance of all work, services, and activities done pursuant to this Contract, an independent contractor and not an employee, agent, or servant of the City. All persons engaged in any of the work or services performed pursuant to this Contract shall at all times, and in all places, be subject to the Contractor's sole direction, supervision, and control. The Contractor shall exercise control over the means and manner in which it and its employees perform the work, and in all respects the Contractor's relationship and the relationship of its employees to the City shall be that of an independent contractor and not as employees or agents of the City. The Contractor does not have the power or authority to bind the City in any promise, agreement or representation other than as specifically provided for in this Contract. The Contractor shall not pledge the City's credit or make it a guarantor of payment of surety for any contract, debt, obligation, judgment, lien or any form of indebtedness. The Contractor further warrants and represents that it has no obligation or indebtedness that would impair its ability to fulfill the terms of this Contract.
- 12. SUBCONTRACTORS AND SUPPLIERS:** Contractor must furnish City with a list of all subcontractors and suppliers prior to any payments against the Contract. All subcontractors are subject to City approval. No change in subcontractors or suppliers shall be made without written consent and approval from the City. All subcontractors shall comply with Section 448.095, Fla. Stat. for registration and use of the E-Verify system operated by the United States Department of Homeland Security.
- 13. LICENSES AND PERMITS/LAWS AND REGULATIONS:** The Contractor must pay all taxes required by law in connection with the activities done in furtherance of this Contract including sales, use, and similar taxes, and unless mutually agreed to in writing to the contrary must secure all licenses and permits necessary for proper completion of the work, paying any fees therefore. Violation of any local, state, or federal law in the performance of this Contract shall constitute a material breach of this Contract. The Contractor must comply with all laws, ordinances, rules, regulations, and orders of all public authorities relating to the performance of the work herein. If any of the Contract documents are at variance therewith, the Contractor must notify the City promptly on the discovery of such variance.

**14. AMENDMENT:**

A. Except as otherwise provided herein, this Contract constitutes the sole and complete understanding between the parties and supersedes all other contracts between them, whether oral or written, with respect to the subject matter. No amendment, change, or addendum to this Contract is enforceable unless agreed to in writing by both parties and incorporated into this Contract.

B. The City Manager or designee may agree to amendments that do not increase compensation to the Contractor. Only the City Commission can approve increases in compensation under this Contract. In the event the Contractor begins work on unauthorized changes to scope prior to receiving a signed Change Order by the City Manager or designee, the Contractor does so at its own expense and risk as unauthorized work shall not be paid for by the City.

**15. EQUAL EMPLOYMENT OPPORTUNITY:** The City of North Port, Florida, in accordance with the provisions of Title VII of the Civil Rights Act of 1964 (78 Stat. 252) and the Regulations of the Department of Commerce (15 CFR, Part 8) issued pursuant to such Act, hereby notifies all bidders that it will ensure that in any Contract entered into pursuant to this advertisement, minority business enterprises will be afforded full opportunity to submit replies in response to this advertisement and will not be discriminated against on the ground of race, color or national origin in consideration for an award.

**16. NON-DISCRIMINATION:** The City of North Port, Florida, does not discriminate on the basis of race, color, national origin, sex, age, disability, family, or religious status in administration of its programs, activities, or services. Contractor must not administer this Contract in an unlawfully discriminatory manner, nor deny participation in or the benefits of same to any individual based on that individual's race, color, national origin, sex, age, disability, family, or religious status, marital status, sexual orientation, gender identity or expression, or physical characteristic.

**17. ASSIGNMENT:** The Contractor must not assign any interest in this Contract and must not transfer any interest in same (whether by assignment or novation) without the prior written consent of the City Manager or designee, except that claims for the money due or to become due the Contractor from the City under this Contract may be assigned to a financial institution or to a trustee in bankruptcy. Notice must be promptly given to the City.

**18. BINDING EFFECT/COUNTERPARTS:** By the signatures affixed hereto, the parties intend to be bound by the terms and conditions hereof. This Contract is binding upon and shall inure to the benefit of the parties and their respective heirs, executors, administrators, successors and assigns. It may be signed in counterparts.

**19. NOTICES:**

Any notice, demand, communication, or request required or permitted hereunder must be sent by certified mail, return receipt requested, and mailed and e-mailed to:

**As to the City:** Michael Acosta, P.E. Engineering Manager  
**City of North Port Utilities**  
**E-Mail:** macosta@cityofnorthport.com

**With copies of notices**

**and demands sent to:** City of North Port, Florida  
City Attorney's Office  
4970 City Hall Boulevard  
North Port, Florida 34286

northportcityattorney@cityofnorthport.com

**As to Contractor:**

Notices are effective when received at the addresses specified above. Changes to the respective addresses may be made from time to time by either party by written notice directed to the other party. Nothing in this Article shall be construed to restrict the transmission of routine communications between representatives of Contractor and City.

**20. WAIVER:** No delay or failure to enforce any breach of this Contract by either City or Contractor shall be binding upon the waiving party unless such waiver is in writing. In the event of a written waiver, such a waiver must not affect the waiving party's rights with respect to any other or further breach. The making or acceptance of a payment by either party with knowledge of the existence of a default or breach must not operate or be construed to operate as a waiver of any subsequent default or breach.

**21. ATTORNEYS' FEES:** In any proceedings between the parties arising out of or related to this Contract, the prevailing party must be reimbursed all costs, expenses, and reasonable attorneys' fees through all proceedings, at both trial and appellate levels.

**22. GOVERNING LAW, VENUE, AND SEVERABILITY:** The rights, obligations, and remedies of the parties under this Contract are governed by the laws of the State of Florida and the exclusive venue for any legal or judicial proceedings in connection with the enforcement or interpretation of this Contract is in the Circuit Court of the Twelfth Judicial Circuit in and for Sarasota County, Florida, and the United States District Court for the Middle District of Florida. The invalidity, illegality, or unenforceability of any provision of this Contract shall in no way affect the validity or enforceability of any other portion or provision of the Contract. Any void provision shall be deemed severed from the Contract and the balance of the Contract shall be construed and enforced as if the Contract did not contain the particular portion or provision held to be void.

**23. PARAGRAPH HEADINGS:** Section headings are for the convenience of the parties and for the reference purposes only and shall be given no legal effect.

**24. SCRUTINIZED COMPANIES:**

A. As required by Florida Statutes Section 287.135(5), for contracts of \$1,000,000.00 or less, the Contractor shall certify on a form provide by the City, that it is not on the Scrutinized Companies that Boycott Israel List, created pursuant to Florida Statutes Section 215.4725, and that it is not engaged in a boycott of Israel.

B. As required by Florida Statutes Section 287.135(5), for contracts of \$1,000,000.00 or more, the Contractor shall certify on a form provided by the City, that all of the following are true:

1. It is not on the Scrutinized Companies that Boycott Israel List, created pursuant to Florida Statutes Section 215.4725, and that it is not engaged in a boycott of Israel; and
2. It is not on the Scrutinized Companies with Activities in Sudan list or the Scrutinized Companies with Activities in Iran Petroleum Energy Sector list, created pursuant to Florida Statutes Section 215.473; and
3. It is not engaged in business operations in Cuba or Syria.



**RFB No. 2023-04 RENOVATION OF LIFT STATIONS 29, 45 AND 73**

C. If the Contractor provides a false certification or has been placed on one of the above-noted Lists of Scrutinized Companies or has engaged in business operations in Cuba or Syria, the Contractor will be in breach of this Contract and the City may terminate the Contract.

**D. PENALTY:**

1. A Contractor that has been found to have provided a false certification may be subject to a civil penalty equal to the greater of \$2 million or twice the amount of the Contract, plus all reasonable attorney's fees and costs, including any costs for investigations that led to the finding of the false certification; and
2. Shall be ineligible to bid on any contract with the City for three (3) years after the date the City determined that the Contractor submitted a false certification.

**25. AUTHORITY TO EXECUTE AGREEMENT:** The signature by any person to this Contract shall be deemed a personal warranty that the person has the full power and authority to bind any corporation, partnership, or any other business or governmental entity for which the person purports to act hereunder.

**26. ENTIRE AGREEMENT:** This Agreement incorporates and includes all prior negotiations, correspondence, agreements, or understandings between the parties, and the parties agree that there are no commitments, agreements or understandings concerning the subject matter of this Agreement that are not contained in this document. This Agreement supersedes all other agreements between the parties, whether oral or written, with respect to the subject matter. In the event of any conflict between the provisions of this Contract and the RFB or Contractor's bid, this signed Contract (excluding the RFB and Contractor's bid) shall take precedence, followed by the provisions of the RFB, and then by the terms of the Contractor's bid.

**27. FORCE MAJEURE:**

- A. Should performance of any obligation created under this Agreement become illegal or impossible by reason of:
1. A strike or work stoppage, unless caused by a negligent act or omission of either Party;
  2. An act of God, tornado, hurricane, flood, sinkhole, fire, explosion, landslide, earthquake, epidemic, pandemic, quarantine, pestilence, or extremely abnormal and excessively inclement weather;
  3. An act of a public enemy, act of war, terrorism, effect of nuclear radiation, blockage, insurrection, riot, civil disturbance, state of martial law, or national or international calamity;
  4. A declared emergency of the federal, state, or local government; or
  5. Any other like event that is beyond the reasonable control of the non-performing party; then the performance of any such obligation is suspended during the period of, and only to the extent of, such prevention or hindrance, provided that:
  6. The non-performing party provides written notice within five (5) days of the event of *force majeure*, describing the event in sufficient detail, including but not limited to: the nature of the occurrence, a good faith estimate of the duration of the delay, proof of how the event has precluded the non-performing party from performing, and the means and methods for correcting the delay; and continues to furnish timely reports of all actions required for it to commence or resume performance of its obligations under this Agreement;

7. The excuse of performance is no greater in scope or duration than required by the event of *force majeure*;
  8. No obligations of either party that arose before the *force majeure* are excused as a result of the event of *force majeure*; and
  9. The non-performing party uses all reasonable diligence to remedy its inability to perform.
- B. Economic hardship of a party does not constitute an event of *force majeure*. A party will not be excused from performance due to forces that it could have reasonably prevented, removed, or remediated prior to, during, or immediately after their occurrence.
- C. The non-performing party's affected obligations under this Agreement will be temporarily suspended during, but not longer than, the continuance of the event of *force majeure* and a reasonable time thereafter as may be required to commence or resume performance of its obligations. Notwithstanding the above, performance shall not be excused under this Section for a period exceeding two (2) months, provided that in extenuating circumstances, the City may excuse performance for a longer term.
- D. The term of the Agreement will be extended by a period equal to that during which the non-performing party's performance is suspended under this Section.

**28. E-VERIFY SYSTEM:** Upon entering into this Contract, the Contractor must be registered with and must continue during the term of this Contract to use the Department of Homeland Security E-Verify System as required by Section 448.095, Fla. Stat., Employment Eligibility, including but not limited to, verifying the work authorization status of all newly hired employees, and requiring all subcontractors to provide an affidavit attesting that the subcontractor does not employ, contract with, or subcontract with, an unauthorized alien. The Contractor shall maintain a copy of such affidavit for the duration of the contract.

#### **A. Remedies for Violation or Breach of Contract Terms**

All claims, disputes and other matters in question between the parties to this agreement, arising out of or relating to this agreement or the breach thereof, shall be resolved as provided as follows:

1. To the extent Chapter 558, F.S. is applicable, the parties expressly opt out of the requirements of Chapter 558, F.S., within the mean of §558.005(1), F.S.
2. In the event of a dispute or claim arising out of this Agreement, the parties agree first to try in good faith to settle the dispute by direct discussion. If this is unsuccessful, the parties may enter into mediation in Sarasota County, Florida, with the parties sharing equally in the cost of such mediation.
3. In the event mediation, if attempted, is unsuccessful in resolving a dispute, the parties may proceed to litigation as set for the below.
4. Any dispute, action or proceeding arising out of or related to this Agreement will be exclusively commenced in the state courts of Sarasota County, Florida, or where subject matter jurisdiction exists in the United States District Court for the Middle District of Florida. Each party irrevocably submits and waives any objections to the exclusive personal jurisdiction and venue of such courts, including any objection based on forum non conveniens.
5. The parties agree to waive all rights to trial by jury for any litigation undertaken concerning this Agreement.
6. This Agreement and the rights and obligations of the parties shall be governed by the laws of the State of Florida without regard to its conflict of laws principles.

7. Unless otherwise agreed in writing, the Consultant shall be required to continue its services and all other obligations under this Agreement during the pendency of claim or dispute including, but not limited to, actual period of mediation or judicial proceedings.

**(All contracts over \$150,000)**

#### **B. Patent and Copyrights**

The U.S. Department of Housing and Urban Development (HUD) and Sarasota County retain patent rights and copyrights on any project which involves research, developmental, experimental, or demonstration work. **(All contracts)**

#### **C. Adherence to State Energy Conservation Plan**

The successful bidder shall recognize and adhere to mandatory standards and policies relating to energy efficiency which are contained in the State energy conservation plan issued in compliance with Energy Policy and Conservation Act (Public Law 94-163). **(All contracts)**

#### **D. Access to Records**

Sarasota County, the consultant operating on behalf of Sarasota County, the State of Florida, the U.S. Department of HUD, the Comptroller General of the United States, or any of their authorized representatives, shall have access to any books, documents, papers, and records of the contractor which are directly pertinent to this contract, for the purpose of performing audit or project monitoring, and such records shall be subject to examination, copying, excerpting or transcribing.

**(All contracts)**

#### **E. Records Retention**

In general, records are to be retained for 4 years from the date of submission of the grantee's fiscal year-end report in which the specific activity is reported for the last time, unless there is litigation, claims, audit, negotiation, or other actions involving the records, which has started before expiration of the 4-year period. In such cases, the records must be retained until completion of the action and resolution of all issues which arise from it or the end of the regular 4-year period, whichever is longer. **(All contracts)**

#### **F. Equal Employment Opportunity**

Except as otherwise provided under 41 CFR Part 60, for all contracts that meet the definition of "federally assisted construction contract" in 41 CFR Part 60-1.3, the contractor is required to comply with 41 CFR Part 60-1.4(b), EO 11246, "Equal Employment Opportunity," (30 FR 12319, 12935, 3 CFR Part, 1964-1965 Comp., P339) as amended by E.O. 11375, "Amending Executive Order 11246 Relating to Equal Employment Opportunity", and implementing regulations at 41 CFR Part 60 "Office of Federal Contract Compliance Programs, Equal Employment Opportunity, Department of Labor". The Contractor is required to include this in all subcontracts involving federally assisted construction contracts. **(All contracts)**

#### **G. Federal Equal Opportunity Laws**

1. Certification of Non-segregated Facilities (for contracts over \$10,000)
2. Title VI, Civil Rights Act of 1964
3. Section 109 of the Housing & Community Development Act of 1974
4. Section 503 Handicapped (for contracts \$2,500 or over)

5. Age Discrimination Act of 1975

6. Section 504 of the Rehabilitation Act of 1973

#### **H. Rights to Inventions Made Under a Contract**

Contractor shall comply with 37 CFR Part 401, "Rights to Inventions Made by Nonprofit Organizations and Small Business Firms Under Government Grants, Contracts and Cooperative Agreements", and any implementing regulations issued by HUD. **(All contracts)**

#### **I. Procurement of Recovered Material**

A non-federal entity that is a state agency or agency of a political subdivision of a state and its contractors must comply with section 6002 of the Solid Waste Disposal Act, as amended by the Resource Conservation and Recovery Act. The requirements of Section 6002 include procuring only items designated in guidelines of the Environmental Protection Agency (EPA) at 40 CFR part 247 that contain the highest percentage of recovered materials practicable, consistent with maintaining a satisfactory level of competition, where the purchase price of the item exceeds \$10,000 or the value of the quantity acquired during the preceding fiscal year exceeded \$10,000; procuring solid waste management services in a manner that maximizes energy and resource recovery; and establishing an affirmative procurement program for procurement of recovered materials identified in the EPA guidelines. **(All contracts over \$10,000)**

#### **J. Byrd Anti-Lobbying Amendment (31 U.S.C. 1352)**

Contractor is required to file the required certification for Bids over \$100,000.00. Each tier certifies to the tier above that it will not and has not used Federal appropriated funds to pay any person or organization for influencing or attempting to influence an officer or employee of any agency, a member of Congress, officer or employee of Congress, or an employee of a member of Congress in connection with obtaining any Federal Contract, grant or other award covered by 31 U.S.C. 1352. Each tier shall also disclose any lobbying with non-Federal funds that takes place in connection obtaining any Federal award. **(All contracts over \$100,000)**

#### **K. Data Universal Numberings**

All contractors participating in this project must have a Data Universal Numbering System (DUNS) number and be registered on the federal System for Award Management (SAM) at sam.gov. **(All contracts)**

#### **L. Debarment and Suspension**

A contract award (see 2 CFR 180.220) must not be made to parties listed on the governmentwide Excluded Parties List System in the System for Award Management (SAM), in accordance with the OMB guidelines at 2 CFR 180 that implement Executive Orders 12549 (3 CFR Part 1986 Comp., p. 189) and 12689 (3 CFR Part 1989 Comp., p. 235), "Debarment and Suspension." The Excluded Parties List System in SAM contains the names of parties debarred, suspended, or otherwise excluded by agencies, as well as parties declared ineligible under statutory or regulatory authority other than Executive Order 12549. **(All contracts)**

#### **M. Restriction on all Public Works Projects**

No contractor, or subcontractor, of a foreign country included on the list of countries that discriminate against U.S. firms published by the Office of the United States Trade Representative (USTR) may be awarded a contract or a subcontract for public works projects. Nor may any product of a country included on this list be provided under a public works

## RFB No. 2023-04 RENOVATION OF LIFT STATIONS 29, 45 AND 73

project. Any offerer unable to certify compliance with this provision shall submit with its offer a written explanation fully describing the reasons for its inability to comply. **(All contracts)**

### N. Drug-Free Workplace Requirements

The Drug-Free Workplace Act of 1988 (42 U.S.C. 701) requires grantees (including individuals) of federal agencies, as a prior condition of being awarded a grant, to certify that they will provide drug-free workplaces. Contractor is required to comply with drug-free workplace requirements in accordance with the Act and with HUD rules at 24 CFR Part 24, Sub-Part F. **(All contracts)**

### O. Clean Air and Water Act

The contract must comply with all applicable standards, orders, or requirements issued under the Clean Air Act (42 U.S.C. 7401-7671q.) and the Federal Water Pollution Control Act (33 U.S.C. 1251-1387), as amended. Violations must be reported to the Federal awarding agency and the Regional office of the Environmental Protection Agency (EPA). **(All contracts over \$150,000)**

### P. Davis-Bacon Requirements

The contractor shall comply with the Davis-Bacon Act, as amended (40 USC 3141-3148) as supplemented by Department of Labor regulations (29 CFR, Part 5). Under this Act contractors shall be required to pay wages to laborers and mechanics at a rate not less than the minimum wages specified in a wage determination made by the Secretary of Labor. In addition, contractors shall be required to pay wages not less often than once a week. A copy of the prevailing wage rates is included in this solicitation. Any known changes to these wage rates prior to award of contract, shall be made known to offerers. In addition, contractors will be required to provide payroll information to Sarasota County on a weekly basis for verification of compliance. Sarasota County shall report all suspected or reported violations of this condition to the U.S. Department of Housing and Urban Development and/or the U.S. Department of Labor. **(All construction contracts over \$2,000)**

### Q. Copeland "Anti-Kickback Act"

The contractor shall comply with the Copeland "Anti-Kickback" Act (40 USC 3145) as supplemented in Department of Labor regulations (29 CFR, Part 3). This Act provides that each contractor or subgrantee shall be prohibited from inducing, by any means, any person employed in the construction, completion, or repair of public work, to give up any part of the compensation to which he is otherwise entitled. Sarasota County shall report all suspected or reported violations to the U.S. Dept. of Housing and Urban Development. **(All construction contracts over \$2,000)**

### R. Contract Work Hours and Safety Standards

The contractor shall comply with 40 USC 3702 and 3704 of the Contract Work Hours and Safety Standards Act as supplemented by Department of Labor regulations (29 CFR, Part 5). Under 40 USC 3702 of the Act, each contractor shall be required to compute the wages of every mechanic and laborer on the basis of a standard workweek of forty (40) hours. Work in excess of that standard work week is permissible provided that the worker is compensated at a rate of not less than one and half times (1.5) the basic rate of pay for all hours worked in excess of forty (40) hours in the work week. (This requirement applies to time spent on federally assisted contracts only.) The requirements of 40 USC 3704 are applicable to construction work and provide that no laborer or mechanic must be required to work in surroundings or under working conditions which are unsanitary, hazardous, or dangerous. These requirements not apply to the purchases of supplies or materials or articles ordinarily available on the open mark, or contracts for transportation or transmission of intelligence. **(All contracts over \$100,000)**

### S. Section 3

Section 3 –According to 24 CFR §75.3(a)(2) a Section 3 project is the site or sites together with any building(s) and improvements located on the site(s) that are under common ownership, management and financing. (This clause is applicable only if the Community Development Block Grant funding exceeds \$200,000, and the funded activity leads to construction i.e. engineering, program management etc.)

#### **Opportunities:**

1. The work to be performed under this contract is subject to the requirements of Section 3 of the Housing and Urban Development Act of 1968, as amended, 12 U.S.C. 1701u (Section 3). The purpose of Section 3 is to ensure employment and other economic opportunities to the greatest extent feasible to low- and very-low income persons and businesses.

2. The parties to this contract agree to comply with HUD’s regulations in 24 CFR §75, which implement Section 3. As evidenced by their execution of this contract, the parties to this contract certify that they are under no contractual or other impediment that would prevent them from complying with the part 75 regulations. To the greatest extent feasible, the Prime Contractor should encourage Section 3 Workers or Business Concerns to participate in the project.

3. According to §75.5 the Section 3 Targeted Worker is a low- or very-low income worker residing within the neighborhood or service area of the project, and a ‘Section 3 Worker’ is any worker who currently fits or when hired within the past five years (since 11-30-2020) fit at least one of the following criteria:

- Low- or very low-income, as established by HUD’s income limits;
- Employed by a Section 3 business concern; or
- A Youth Build participant.

Documentation must be maintained to ensure workers meet the definitions. Requirements for a Section 3 Worker may include:

- Worker’s self-certification that their income is below the income limit from the prior calendar year;
- Worker’s self-certification of participation in a means-tested program such as Public Housing or Section 8;
- Certification from a Public Housing Authority (PHA) or Section 8 program manager that the worker is a participant in such a program;
- Employer’s certification that the worker’s income from that employer is below the income limit; or
- Employer’s certification that the worker is employed by a Section 3 Business Concern.

Requirements for a Targeted Section 3 Worker may include:

- Worker’s self-certification of participation in a means tested program such as Public Housing or Section 8;
- Certification from a PHA or Section program manager that the worker is a participant in such a program;
- Employer’s certification that the worker is employed by a Section 3 Business Concern; or
- Worker’s certification that the worker is a Youth Build participant.

4. According to §75.5 businesses that meet one of the following criteria within the last six (6) months are considered Section 3 Business Concerns:

- At least 51% owned and controlled by low-income or very low-income persons;
- Over 75% of labor hours performed for the business over prior 3-month period are performed by Section 3 Workers;
- At least 51% owned and controlled by current residents of public housing or Section 8 assisted housing; and
- Businesses must verify their status as a Section 3 business concern at the time the contract is awarded.

## RFB No. 2023-04 RENOVATION OF LIFT STATIONS 29, 45 AND 73

5. Qualitative reporting based upon §75.25(b) would include a description of efforts taken to meet requirements for Section 3 Workers or Business Concerns. Examples include:

- Holding Job Fairs;
- Conduct On-Job Training; or
- Outreach Efforts to Public Housing Residents.

Section 3 is race and gender neutral. If a business qualifies as a Section 3 Business, the business owner(s) are encouraged to register as such on HUD's Section 3 Registry which can be found at:

<https://portalapps.hud.gov/Sec3BusReg/BRegistry/BRegistryHome>

### **(Contracts Greater Than \$200,000)**

#### **N. Termination**

All contracts in excess of \$10,000 must address termination for cause and for convenience by the non-Federal entity including the manner by which it will be effected and the basis for settlement, as found in RFB 2023-04

#### **(All contracts over \$10,000)**

#### **O. Bonding**

Contractor must meet the following minimum requirements:

(1) A bid guarantee from each bidder equivalent to five percent of the bid price. The "bid guarantee" must consist of a firm commitment such as a bid bond, certified check, or other negotiable instrument accompanying a bid as assurance that the bidder will, upon acceptance of the bid, execute such contractual documents as may be required within the time specified.

(2) A performance bond on the part of the contractor for 100 percent of the contract price. A "performance bond" is one executed in connection with a contract to secure fulfillment of all the contractor's obligations under such contract.

(3) A payment bond on the part of the contractor for 100 percent of the contract price. A "payment bond" is one executed in connection with a contract to assure payment as required by law of all persons supplying labor and material in the execution of the work provided for in the contract. **(All contracts over \$150,000)**

#### **V. Insurance**

The following insurance items are required, as found in RFB 2023-04

IN WITNESS WHEREOF, the parties have executed the agreement as of the date as follows.

**CONTRACTOR:**

By: \_\_\_\_\_

Name:

Title:

**ACKNOWLEDGEMENT**

STATE OF \_\_\_\_\_

COUNTY OF \_\_\_\_\_

The foregoing instrument was acknowledged before me by means of  physical presence or  online notarization, this \_\_\_ day of \_\_\_\_\_ 20\_\_, by \_\_\_\_\_ (name), as \_\_\_\_\_ (title) for \_\_\_\_\_ (entity).

\_\_\_\_\_  
Notary Public

\_\_\_ Personally Known OR \_\_\_ Produced Identification

Type of Identification Produced \_\_\_\_\_

Approved by the City Commission of the City of North Port, Florida on \_\_\_\_\_, 2022.

**CITY OF NORTH PORT, FLORIDA**

By: \_\_\_\_\_

A. Jerome Fletcher II, ICMA-CM,  
City Manager

**ATTEST**

\_\_\_\_\_  
Heather Faust, MMC  
City Clerk

**APPROVED AS TO FORM AND CORRECTNESS**

\_\_\_\_\_  
Amber L. Slayton, City Attorney





**City of North Port**  
FINANCE DEPARTMENT/PURCHASING DIVISION  
4970 CITY HALL BLVD, STE 337  
NORTH PORT, FLORIDA 34287  
Office: 941.429.7170  
Fax: 941.429.7173  
Email: [purchasing@cityofnorthport.com](mailto:purchasing@cityofnorthport.com)



**August 11, 2022**  
**ADDENDUM 1**

**TO: PROSPECTIVE BIDDERS**

**RE: RFB NO. 2023-04 Renovation of Lift Stations 29, 45 and 73 CDBG**

**DUE DATE August 24, 2022**

**City Hall, Room 337A (Bids need to be delivered to Room 337 so they can be date and time stamped on or before 2:00 PM. Bid opening will commence in Room 337A shortly thereafter)**

---

Bidders are hereby notified that this addendum shall be made part of the above-named bid and contract documents. The following changes to the above bid are issued to modify, and/or clarify the bid and contract documents (the deletions are as ~~striketroughs~~ and additions as underlined). These items shall have the same force and effect as the original documents, and bids to be submitted on the specified date shall conform with the additions, deletions and revisions as listed herein.

- **PRE BID MEETING SIGN IN SHEET ATTACHED.**
- **Estimate Flow Rates Attached**
- **G-4 Detail- attached**

Q1: Are we required to have three billboards?

**A1: The Wage Determination Rates, minimum wage posters and Davis Bacon posters can be posted at only one of the three lift station site. The posted sign can be moved to the most active construction site in the case of two or more stations being simultaneously under construction. The signage must remain in place for the entire project.**

Q2: We won't be allowed to have three stations on by-pass at once?

**A2: Only one station can be bypassed at any one time. Work can proceed at all stations simultaneously other than bypassing.**

Q3: The plans show a future pad for odor control and by-pass pump, is that needed?

**A3: Concrete pads for the bypass pump and odor control unit will not be required for this project.**

Q4: Is there a detail for the by-pass pump, when it comes to the manifold?

**A4: The manifold shall be as shown on LS 01 and LS02. The tee where the diesel bypass pump is shown to connect will have a blind flange installed. Please see attached for more clarity.**

Q5: Can we get a clarification on how the piping is supposed to be?

**A5: Piping is as shown on the detail and can be field adjusted with City staff at the time of installation. City approval must be secured in writing before deviating from the detail.**

Q6: What is the engineer's estimate?

**A6: \$453,005.00**

Q7: What are the estimated flow rates for these stations?

**A7: Please see attached pump run time spreadsheet.**

Q8: Will As-builts be required?

**A8: Any below ground installation shall has an as-built record drawing submitted after construction.**

Q9: Buried Plug valves, the valves boxes require detail G4, I don't see detail G4?

**A9: See attached.**

Q10: Are we replacing to the isolation valve below ground?

**A10: No.**

Q11: Is there a detail requirement for the sign?

**A11: The city/county will provide the required posters and information to be displayed on the sign at the pre-construction meeting.**

Q12: Can we do site visits of the Lift Stations?

**A12: Yes, Tuesday, August 16, 2022, 9:30 AM Lift Station #29 at 8358 Denargo Road. As a reminder, please do not ask questions during the site visits of City staff members.**

Q13: Can you clarify the Davis Bacon threshold?

**A13: Any CDBG job over \$2,000 requires Davis Bacon.**

**Firms are required to acknowledge receipt of this addendum on their proposal forms. All other terms and conditions of the original proposal and contract documents remain the same.**

*Keith Raney*

---

**Keith Raney, CPPB, CPPO**  
**Contract Administrator II**  
**Finance Department/Purchasing Division**  
**4970 City Hall Blvd.**  
**North Port, Florida 34286**  
**Tel: 941.429.7103**  
**Fax: 941.429.7173**  
**E-mail: [kraney@cityofnorthport.com](mailto:kraney@cityofnorthport.com)**

**Receipt of Addendum No. 1 shall be noted within the Bid Form in the appropriate section.**  
**End of Addendum No.1**

(OPEN TO PUBLIC)

RFB NO. 2023-04  
Renovation of Lift Stations 29,45, and 73  
PRE-BID MEETING SIGN-IN SHEET

August 3, 2022 2:00 PM

CITY HALL, ROOM 244

YOUR NAME/TITLE	COMPANY NAME	PHONE/E-MAIL
Keith Raney Contract Administrator II	Finance Department Purchasing Division	Ph. 941.429.7103 <a href="mailto:kraney@cityofnorthport.com">kraney@cityofnorthport.com</a>
Jennifer Fehrs Project Manager <i>JF</i>	City of North Port Utilities Department	<a href="mailto:jfehrrs@cityofnorthport.com">jfehrrs@cityofnorthport.com</a> 941-240-8008 (Office)
Michael Acosta, PE Utilities Engineering Manager	City of North Port Utilities Department	<a href="mailto:macosta@cityofnorthport.com">macosta@cityofnorthport.com</a> 941.240.8013 (Office)
Nicole Brown Business Services Coordinator	City of North Port Utilities Department	<a href="mailto:nbrown@cityofnorthport.com">nbrown@cityofnorthport.com</a> 941-240-8025 (Office)
Valerie Malingowski Grant Division Manager <i>VM</i>	City of North Port City Manager	<a href="mailto:vmalingowski@cityofnorthport.com">vmalingowski@cityofnorthport.com</a>
Dale Flocker	GM & Coatings	941-281-9236 Dale @ gmicoatings.com
STGUS STANTON	US WATER SERVICES	239-209-6120 STANTON @ USWATERCORP.NET
Mason McPherson John Blank	US water services ECS -	239-222-1009 mmcpherson@uswatercorp.net 941-995-5925 jblank@ecscoatings.com

YOUR NAME/TITLE	COMPANY NAME	TELEPHONE AND E-MAIL
Ray Dario	Innovative Contractors	941 549 9300 P.O. Innovative-Contractors.com

Kevin Conkle Chief Administrative Officer	Tru Spec Mechanical Inc	570 W. 52 <sup>nd</sup> +337 Kevin Con @ Tru Spec Fl. com
Cindy Emshoff via Teams- OHCD Sarasota	City of Sarasota.	
Leigh DeJonge	DeJonge Exc.	Dex @ DeJonge Excavating.com LDeJonge @ DeJonge Excavating.com
Andrew DeJonge	DeJonge Exc.	A DeJonge @ DeJonge Excavating.com

Activity Report

Report On 29A1,29A2,45A1,73A1,73A2

From 00:00 07/01/ To 24:00 07/31/22 Time Filter 00:00 - 24:00

1-Jul-22

Point Name	Address	Min Ontime	Max Ontime	Total Ontime	Avg Ontime	Times On
LS029						
Pump 1 Status	29A1	0:00:38	0:29:44	11:12:59	0:17:04	39
Pump 2 Status	29A2	0:08:27	0:16:07	8:00:31	0:12:14	39
LS045						
Pump 1 Status	45A1	0:00:30	0:01:35	0:15:53	0:00:38	25
LS073						
Pump 1 Status	73A1	0:01:36	0:02:37	0:29:32	0:01:50	16
Pump 2 Status	73A2	0:01:34	0:02:45	0:28:48	0:01:48	16

2-Jul-22

Point Name	Address	Min Ontime	Max Ontime	Total Ontime	Avg Ontime	Times On
LS029						
Pump 1 Status	29A1	0:00:52	0:43:57	6:29:01	0:16:22	23
Pump 2 Status	29A2	0:01:28	0:19:14	12:09:05	0:12:11	59
LS045						
Pump 1 Status	45A1	0:00:30	0:01:34	0:17:36	0:00:39	27
LS073						
Pump 1 Status	73A1	0:01:36	0:02:08	0:27:40	0:01:43	16
Pump 2 Status	73A2	0:01:34	0:02:41	0:31:19	0:01:50	17

3-Jul-22

Point Name	Address	Min Ontime	Max Ontime	Total Ontime	Avg Ontime	Times On
LS029						
Pump 1 Status	29A1	0:00:00	0:00:00	0:00:00	0:00:00	0
Pump 2 Status	29A2	0:05:59	0:21:48	17:25:15	0:10:48	96
LS045						
Pump 1 Status	45A1	0:00:28	0:01:37	0:20:15	0:00:45	27
LS073						
Pump 1 Status	73A1	0:01:38	0:02:40	0:31:07	0:01:56	16
Pump 2 Status	73A2	0:01:36	0:02:40	0:31:36	0:01:58	16

4-Jul-22

Point Name	Address	Min Ontime	Max Ontime	Total Ontime	Avg Ontime	Times On
LS029						
Pump 1 Status	29A1	0:00:00	0:00:00	0:00:00	0:00:00	0
Pump 2 Status	29A2	0:05:41	0:17:28	17:20:50	0:10:50	95
LS045						
Pump 1 Status	45A1	0:00:30	0:01:32	0:17:18	0:00:37	28
LS073						
Pump 1 Status	73A1	0:01:36	0:02:51	0:29:57	0:01:45	17
Pump 2 Status	73A2	0:01:36	0:02:32	0:31:00	0:01:56	16

5-Jul-22

Point Name	Address	Min Ontime	Max Ontime	Total Ontime	Avg Ontime	Times On
LS029						
Pump 1 Status	29A1	0:05:23	0:19:03	3:06:23	0:13:18	14
Pump 2 Status	29A2	0:02:13	0:14:26	13:40:36	0:09:10	89
LS045						
Pump 1 Status	45A1	0:00:28	0:01:25	0:13:56	0:00:36	23
LS073						
Pump 1 Status	73A1	0:01:36	0:02:34	0:28:41	0:01:54	15
Pump 2 Status	73A2	0:01:34	0:02:19	0:26:33	0:01:46	15

6-Jul-22

Point Name	Address	Min Ontime	Max Ontime	Total Ontime	Avg Ontime	Times On
LS029						
Pump 1 Status	29A1	0:00:04	0:25:40	3:28:21	0:05:37	37
Pump 2 Status	29A2	0:00:04	0:34:40	12:29:42	0:10:16	73
LS045						
Pump 1 Status	45A1	0:00:30	0:01:13	0:16:17	0:00:37	26
LS073						
Pump 1 Status	73A1	0:01:34	0:02:45	0:32:41	0:01:55	17
Pump 2 Status	73A2	0:01:34	0:02:23	0:33:56	0:01:53	18

7-Jul-22

Point Name	Address	Min Ontime	Max Ontime	Total Ontime	Avg Ontime	Times On
LS029						
Pump 1 Status	29A1	0:04:08	0:06:46	4:56:12	0:05:17	56
Pump 2 Status	29A2	0:08:10	0:21:08	11:18:03	0:12:06	56

LS045						
Pump 1 Status	45A1	0:00:30	0:01:07	0:14:09	0:00:35	24
LS073						
Pump 1 Status	73A1	0:01:34	0:02:20	0:32:54	0:01:49	18
Pump 2 Status	73A2	0:01:36	0:02:47	0:36:09	0:02:00	18
8-Jul-22						
Point Name	Address	Min Ontime	Max Ontime	Total Ontime	Avg Ontime	Times On
LS029						
Pump 1 Status	29A1	0:03:56	0:05:52	4:56:26	0:05:04	58
Pump 2 Status	29A2	0:08:05	0:14:16	10:57:21	0:11:08	59
LS045						
Pump 1 Status	45A1	0:00:30	0:01:26	0:14:56	0:00:37	24
LS073						
Pump 1 Status	73A1	0:01:34	0:02:47	0:29:18	0:01:57	15
Pump 2 Status	73A2	0:01:34	0:02:43	0:26:29	0:01:53	14
9-Jul-22						
Point Name	Address	Min Ontime	Max Ontime	Total Ontime	Avg Ontime	Times On
LS029						
Pump 1 Status	29A1	0:03:46	0:05:52	4:45:22	0:04:42	60
Pump 2 Status	29A2	0:06:52	0:13:49	10:11:50	0:10:06	60
LS045						
Pump 1 Status	45A1	0:00:30	0:01:35	0:18:45	0:00:43	26
LS073						
Pump 1 Status	73A1	0:01:34	0:02:18	0:25:48	0:01:50	14
Pump 2 Status	73A2	0:01:34	0:02:42	0:29:09	0:01:56	15
10-Jul-22						
Point Name	Address	Min Ontime	Max Ontime	Total Ontime	Avg Ontime	Times On
LS029						
Pump 1 Status	29A1	0:03:48	0:05:39	4:47:33	0:04:38	61
Pump 2 Status	29A2	0:06:59	0:13:31	9:56:44	0:09:43	61
LS045						
Pump 1 Status	45A1	0:00:28	0:01:02	0:14:54	0:00:35	25
LS073						
Pump 1 Status	73A1	0:01:36	0:02:17	0:30:28	0:01:54	16



Pump 2 Status	73A2	0:01:38	0:02:19	0:29:11	0:01:56	15
11-Jul-22						

Point Name	Address	Min Ontime	Max Ontime	Total Ontime	Avg Ontime	Times On
LS029						
Pump 1 Status	29A1	0:03:38	0:05:01	4:39:04	0:04:21	64
Pump 2 Status	29A2	0:06:44	0:10:52	9:09:57	0:08:35	64
LS045						
Pump 1 Status	45A1	0:00:30	0:01:03	0:14:10	0:00:35	24
LS073						
Pump 1 Status	73A1	0:01:36	0:02:11	0:25:10	0:01:47	14
Pump 2 Status	73A2	0:01:36	0:02:23	0:28:26	0:02:01	14
12-Jul-22						

Point Name	Address	Min Ontime	Max Ontime	Total Ontime	Avg Ontime	Times On
LS029						
Pump 1 Status	29A1	0:00:02	0:21:49	4:30:40	0:04:35	59
Pump 2 Status	29A2	0:00:02	1:36:13	9:16:03	0:09:06	61
LS045						
Pump 1 Status	45A1	0:00:30	0:01:05	0:17:04	0:00:37	27
LS073						
Pump 1 Status	73A1	0:01:36	0:02:25	0:24:07	0:01:51	13
Pump 2 Status	73A2	0:01:36	0:02:19	0:27:22	0:01:57	14
13-Jul-22						

Point Name	Address	Min Ontime	Max Ontime	Total Ontime	Avg Ontime	Times On
LS029						
Pump 1 Status	29A1	0:03:28	0:04:37	4:27:53	0:03:59	67
Pump 2 Status	29A2	0:05:50	0:10:04	8:16:42	0:07:24	67
LS045						
Pump 1 Status	45A1	0:00:32	0:01:01	0:13:37	0:00:37	22
LS073						
Pump 1 Status	73A1	0:01:36	0:02:27	0:26:59	0:01:55	14
Pump 2 Status	73A2	0:01:34	0:02:21	0:26:47	0:01:54	14
14-Jul-22						

Point Name	Address	Min Ontime	Max Ontime	Total Ontime	Avg Ontime	Times On
LS029						

Pump 1 Status	29A1	0:03:12	0:06:54	3:43:23	0:04:04	54
Pump 2 Status	29A2	0:05:29	3:52:56	10:52:51	0:12:05	54
LS045						
Pump 1 Status	45A1	0:00:30	0:00:57	0:14:50	0:00:35	25
LS073						
Pump 1 Status	73A1	0:01:36	0:02:30	0:32:45	0:01:55	17
Pump 2 Status	73A2	0:01:36	0:02:37	0:30:26	0:01:54	16

15-Jul-22

Point Name	Address	Min Ontime	Max Ontime	Total Ontime	Avg Ontime	Times On
LS029						
Pump 1 Status	29A1	0:04:02	0:06:17	4:56:29	0:05:16	56
Pump 2 Status	29A2	0:08:45	0:19:46	12:21:14	0:13:14	56
LS045						
Pump 1 Status	45A1	0:00:28	0:00:36	0:14:18	0:00:33	26
LS073						
Pump 1 Status	73A1	0:01:36	0:02:47	0:30:54	0:02:03	15
Pump 2 Status	73A2	0:01:34	0:02:35	0:27:28	0:01:49	15

16-Jul-22

Point Name	Address	Min Ontime	Max Ontime	Total Ontime	Avg Ontime	Times On
LS029						
Pump 1 Status	29A1	0:03:56	0:11:37	5:00:30	0:05:05	59
Pump 2 Status	29A2	0:08:22	0:16:27	11:33:33	0:11:45	59
LS045						
Pump 1 Status	45A1	0:00:28	0:01:20	0:15:06	0:00:34	26
LS073						
Pump 1 Status	73A1	0:01:34	0:02:36	0:30:46	0:01:48	17
Pump 2 Status	73A2	0:01:34	0:02:54	0:33:38	0:01:58	17

17-Jul-22

Point Name	Address	Min Ontime	Max Ontime	Total Ontime	Avg Ontime	Times On
LS029						
Pump 1 Status	29A1	0:04:01	0:05:31	4:43:55	0:04:43	60
Pump 2 Status	29A2	0:08:05	0:15:53	11:20:40	0:11:19	60
LS045						
Pump 1 Status	45A1	0:00:30	0:01:04	0:14:04	0:00:36	23

LS073

Pump 1 Status	73A1	0:01:36	0:02:17	0:32:46	0:01:55	17
Pump 2 Status	73A2	0:01:36	0:02:25	0:34:08	0:01:53	18

18-Jul-22

Point Name	Address	Min Ontime	Max Ontime	Total Ontime	Avg Ontime	Times On
------------	---------	------------	------------	--------------	------------	----------

LS029

Pump 1 Status	29A1	0:03:40	0:05:30	4:44:12	0:04:22	65
Pump 2 Status	29A2	0:07:04	0:12:45	10:06:48	0:09:16	64

LS045

Pump 1 Status	45A1	0:00:28	0:01:37	0:16:21	0:00:35	28
---------------	------	---------	---------	---------	---------	----

LS073

Pump 1 Status	73A1	0:01:36	0:02:20	0:31:14	0:01:57	16
Pump 2 Status	73A2	0:01:34	0:02:41	0:33:54	0:02:07	16

19-Jul-22

Point Name	Address	Min Ontime	Max Ontime	Total Ontime	Avg Ontime	Times On
------------	---------	------------	------------	--------------	------------	----------

LS029

Pump 1 Status	29A1	0:03:20	0:05:00	4:43:13	0:04:14	66
Pump 2 Status	29A2	0:06:36	0:12:05	9:40:27	0:08:45	66

LS045

Pump 1 Status	45A1	0:00:30	0:01:01	0:16:26	0:00:36	27
---------------	------	---------	---------	---------	---------	----

LS073

Pump 1 Status	73A1	0:01:38	0:02:35	0:30:22	0:02:01	15
Pump 2 Status	73A2	0:01:34	0:02:23	0:28:25	0:01:53	15

20-Jul-22

Point Name	Address	Min Ontime	Max Ontime	Total Ontime	Avg Ontime	Times On
------------	---------	------------	------------	--------------	------------	----------

LS029

Pump 1 Status	29A1	0:03:28	0:05:20	4:35:42	0:04:06	67
Pump 2 Status	29A2	0:06:31	0:11:52	9:26:18	0:08:24	67

LS045

Pump 1 Status	45A1	0:00:28	0:01:08	0:14:46	0:00:35	25
---------------	------	---------	---------	---------	---------	----

LS073

Pump 1 Status	73A1	0:01:36	0:02:39	0:27:03	0:01:55	14
Pump 2 Status	73A2	0:01:30	0:02:14	0:22:53	0:01:45	13

21-Jul-22

Point Name	Address	Min Ontime	Max Ontime	Total Ontime	Avg Ontime	Times On
LS029						
Pump 1 Status	29A1	0:03:08	0:04:42	4:31:12	0:03:55	69
Pump 2 Status	29A2	0:06:10	0:09:20	8:49:38	0:07:41	68
LS045						
Pump 1 Status	45A1	0:00:12	0:01:26	0:14:28	0:00:36	24
LS073						
Pump 1 Status	73A1	0:01:36	0:02:19	0:25:17	0:01:48	14
Pump 2 Status	73A2	0:01:32	0:02:38	0:28:45	0:01:55	15

22-Jul-22

Point Name	Address	Min Ontime	Max Ontime	Total Ontime	Avg Ontime	Times On
LS029						
Pump 1 Status	29A1	0:03:25	0:06:39	4:24:24	0:04:20	61
Pump 2 Status	29A2	0:06:03	0:32:22	10:37:49	0:10:19	60
LS045						
Pump 1 Status	45A1	0:00:30	0:00:59	0:18:06	0:00:35	31
LS073						
Pump 1 Status	73A1	0:01:36	0:02:15	0:29:20	0:01:50	16
Pump 2 Status	73A2	0:01:34	0:02:29	0:29:04	0:01:56	15

23-Jul-22

Point Name	Address	Min Ontime	Max Ontime	Total Ontime	Avg Ontime	Times On
LS029						
Pump 1 Status	29A1	0:04:41	0:06:55	3:21:40	0:05:36	36
Pump 2 Status	29A2	0:10:47	0:27:30	16:40:58	0:17:00	35
LS045						
Pump 1 Status	45A1	0:00:30	0:01:34	0:19:11	0:00:41	28
LS073						
Pump 1 Status	73A1	0:01:34	0:02:37	0:38:02	0:02:00	19
Pump 2 Status	73A2	0:01:32	0:03:20	0:40:54	0:02:09	19

24-Jul-22

Point Name	Address	Min Ontime	Max Ontime	Total Ontime	Avg Ontime	Times On
LS029						
Pump 1 Status	29A1	0:06:00	0:08:48	2:00:59	0:07:07	17
Pump 2 Status	29A2	0:25:23	5:55:41	20:15:48	1:04:45	18

LS045						
Pump 1 Status	45A1	0:00:28	0:01:03	0:16:02	0:00:35	27
LS073						
Pump 1 Status	73A1	0:01:36	0:02:27	0:32:42	0:01:55	17
Pump 2 Status	73A2	0:01:34	0:02:30	0:31:19	0:01:50	17
25-Jul-22						
Point Name	Address	Min Ontime	Max Ontime	Total Ontime	Avg Ontime	Times On
LS029						
Pump 1 Status	29A1	0:01:22	0:13:05	3:22:44	0:06:08	33
Pump 2 Status	29A2	0:06:38	0:35:21	16:31:53	0:19:29	50
LS045						
Pump 1 Status	45A1	0:00:30	0:01:19	0:15:27	0:00:37	25
LS073						
Pump 1 Status	73A1	0:01:34	0:02:38	0:26:49	0:01:54	14
Pump 2 Status	73A2	0:01:34	0:02:34	0:30:56	0:02:03	15
26-Jul-22						
Point Name	Address	Min Ontime	Max Ontime	Total Ontime	Avg Ontime	Times On
LS029						
Pump 1 Status	29A1	0:04:26	0:06:15	4:32:26	0:05:08	52
Pump 2 Status	29A2	0:10:16	0:27:15	13:21:24	0:15:13	52
LS045						
Pump 1 Status	45A1	0:00:30	0:01:29	0:14:57	0:00:37	24
LS073						
Pump 1 Status	73A1	0:01:34	0:02:50	0:30:38	0:01:54	16
Pump 2 Status	73A2	0:01:32	0:02:35	0:27:57	0:01:51	15
27-Jul-22						
Point Name	Address	Min Ontime	Max Ontime	Total Ontime	Avg Ontime	Times On
LS029						
Pump 1 Status	29A1	0:04:10	0:05:59	4:33:18	0:04:58	55
Pump 2 Status	29A2	0:09:03	0:22:24	12:50:07	0:14:04	54
LS045						
Pump 1 Status	45A1	0:00:30	0:00:58	0:13:04	0:00:34	23
LS073						
Pump 1 Status	73A1	0:01:32	0:02:11	0:24:16	0:01:44	14

Pump 2 Status	73A2	0:01:32	0:02:25	0:27:10	0:01:48	15
28-Jul-22						

Point Name	Address	Min Ontime	Max Ontime	Total Ontime	Avg Ontime	Times On
LS029						
Pump 1 Status	29A1	0:04:04	0:05:45	4:42:43	0:04:42	60
Pump 2 Status	29A2	0:08:36	0:20:17	11:44:49	0:11:52	59
LS045						
Pump 1 Status	45A1	0:00:28	0:01:08	0:18:46	0:00:45	25
LS073						
Pump 1 Status	73A1	0:01:36	0:02:24	0:31:40	0:01:58	16
Pump 2 Status	73A2	0:01:36	0:02:28	0:31:01	0:01:56	16
29-Jul-22						

Point Name	Address	Min Ontime	Max Ontime	Total Ontime	Avg Ontime	Times On
LS029						
Pump 1 Status	29A1	0:03:53	0:05:22	4:42:15	0:04:28	63
Pump 2 Status	29A2	0:07:45	0:14:25	10:54:53	0:10:23	63
LS045						
Pump 1 Status	45A1	0:00:30	0:01:00	0:13:52	0:00:36	23
LS073						
Pump 1 Status	73A1	0:01:32	0:02:24	0:29:19	0:01:49	16
Pump 2 Status	73A2	0:01:32	0:02:10	0:28:22	0:01:46	16
30-Jul-22						

Point Name	Address	Min Ontime	Max Ontime	Total Ontime	Avg Ontime	Times On
LS029						
Pump 1 Status	29A1	0:03:47	0:05:09	4:36:22	0:04:23	63
Pump 2 Status	29A2	0:07:15	0:12:39	10:32:42	0:09:53	64
LS045						
Pump 1 Status	45A1	0:00:30	0:01:12	0:14:56	0:00:37	24
LS073						
Pump 1 Status	73A1	0:01:32	0:02:10	0:24:48	0:01:46	14
Pump 2 Status	73A2	0:01:34	0:02:24	0:27:09	0:01:56	14
31-Jul-22						

Point Name	Address	Min Ontime	Max Ontime	Total Ontime	Avg Ontime	Times On
LS029						

Pump 1 Status	29A1	0:03:39	0:05:13	4:35:16	0:04:18	64
Pump 2 Status	29A2	0:06:54	0:15:45	10:18:49	0:09:41	63
LS045						
Pump 1 Status	45A1	0:00:30	0:01:05	0:14:21	0:00:37	23
LS073						
Pump 1 Status	73A1	0:01:34	0:02:26	0:27:58	0:01:51	15
Pump 2 Status	73A2	0:01:32	0:02:24	0:28:41	0:01:54	15
Totals						
Point Name	Address	Min Ontime	Max Ontime	Total Ontime	Avg Ontime	Times On
LS029						
Pump 1 Status	29A1	0:00:02	0:43:57	135:10:37	0:05:15	1544
Pump 2 Status	29A2	0:00:02	7:23:04	368:13:20	0:11:35	1904
LS045						
Pump 1 Status	45A1	0:00:12	0:01:37	8:07:51	0:00:37	785
LS073						
Pump 1 Status	73A1	0:01:32	0:02:51	15:11:01	0:01:53	483
Pump 2 Status	73A2	0:01:30	0:03:20	15:28:55	0:01:55	484
End of Report						

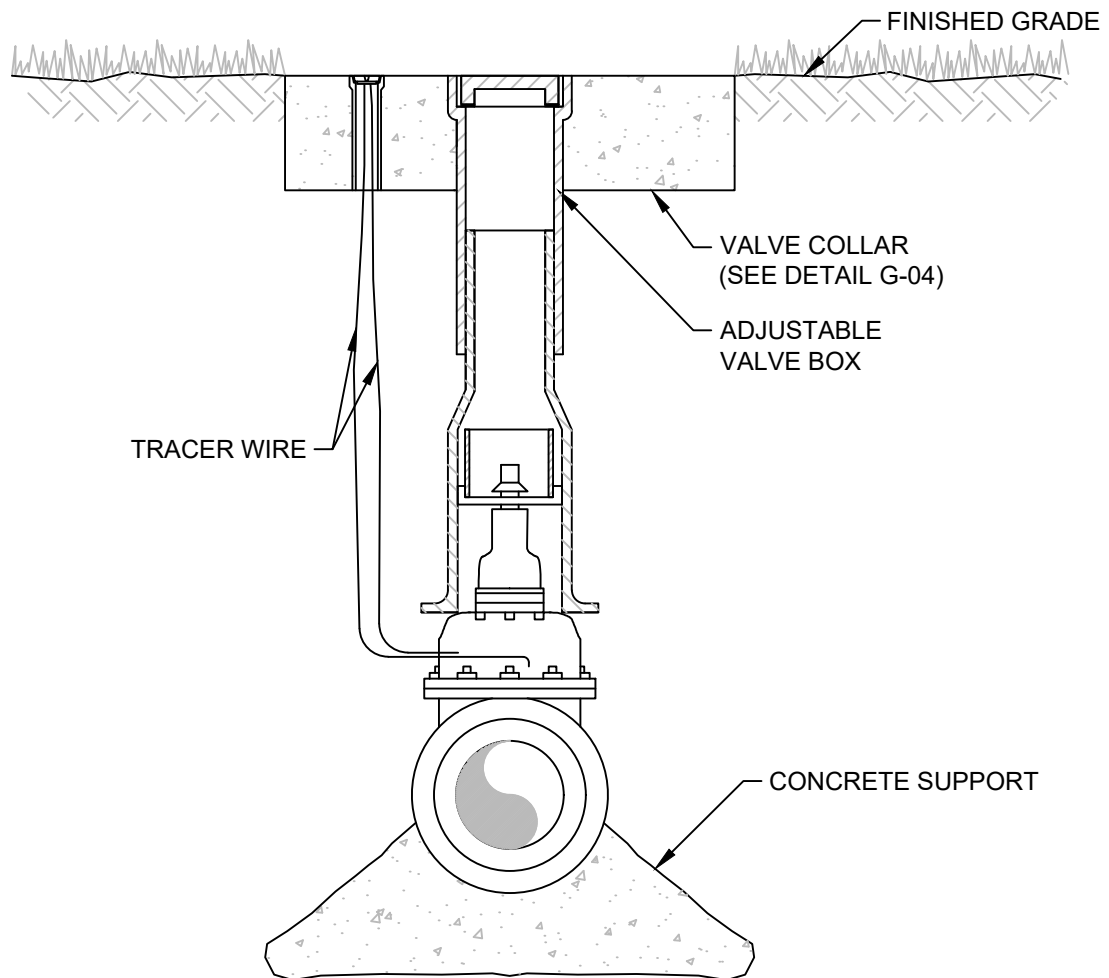

**NOTES:**

1. WHERE THE OPERATING NUT IS GREATER THAN 48 INCHES BELOW THE TOP OF THE VALVE BOX, AN EXTENSION STEM AND ALIGNMENT RINGS SHALL BE PROVIDED TO BRING THE OPERATING NUT TO BETWEEN 6 AND 30 INCHES BELOW THE TOP OF THE VALVE BOX.

general details.dwg Aug-2020



## TYPICAL VALVE AND CONCRETE COLLAR

DETAIL

# G-03

SHEET 1 OF 1



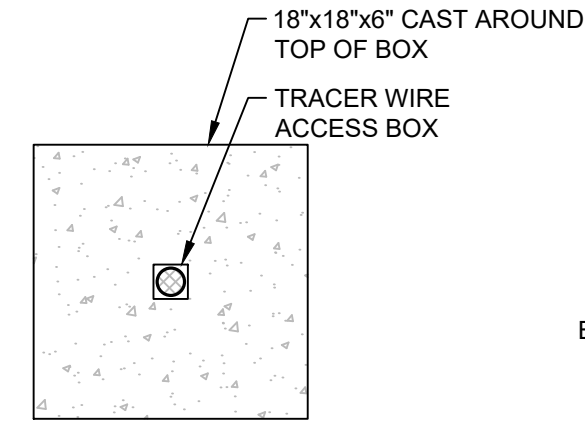

TRACER WIRE ACCESS BOX  
OUTSIDE PAVEMENT

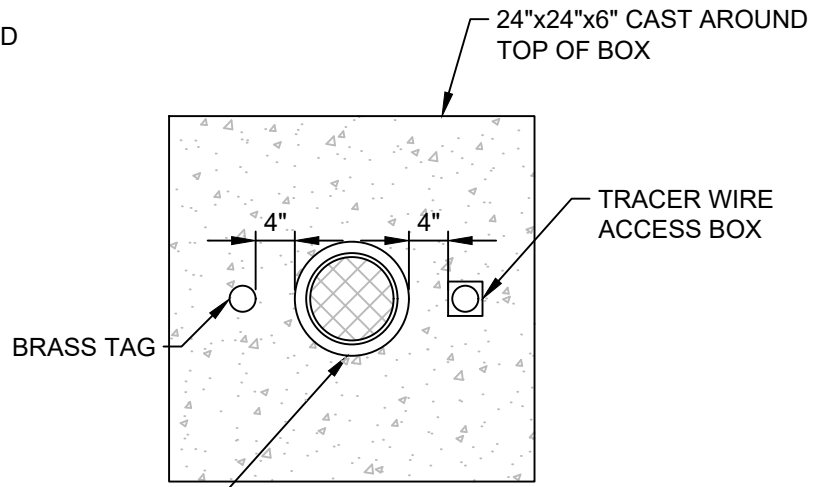

VALVE BOX WITH COVER (TO BE MARKED "WATER", "SEWER", OR "REUSE") AND PAINTED ACCORDINGLY

VALVE COLLAR  
OUTSIDE PAVEMENT

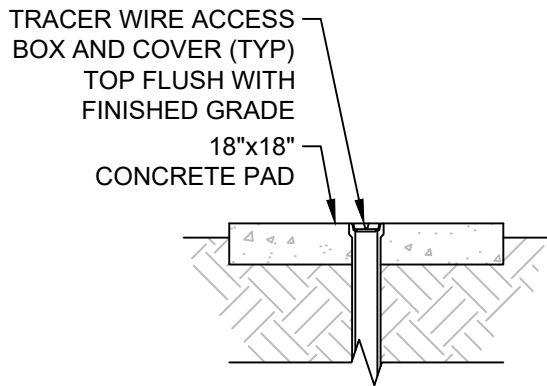

TYPICAL TRACER  
WIRE ACCESS BOX  
SECTION VIEW

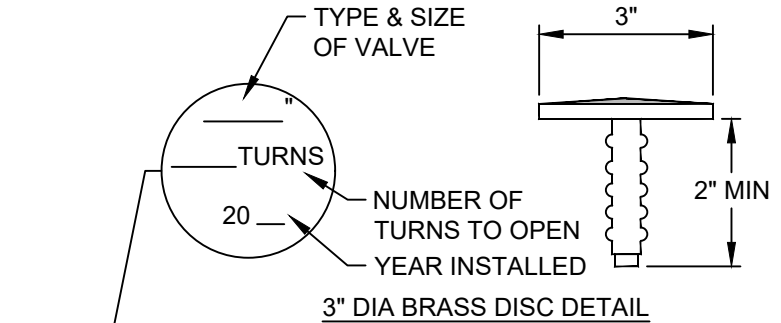

3" DIA BRASS DISC DETAIL

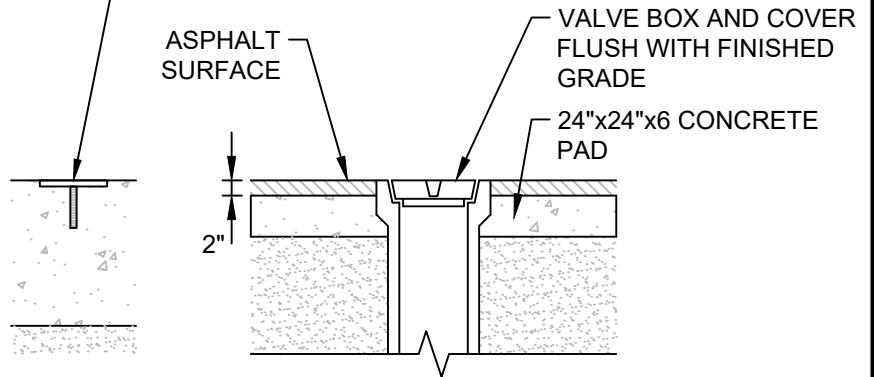

VALVE COLLAR  
INSIDE PAVEMENT

**NOTES:**

1. VALVE PAD SHALL BE USED IN ALL LOCATIONS, INCLUDING SIDEWALK, DRIVEWAY AND ROADWAY APPLICATIONS, AND EXPANSION JOINTS SHALL BE USED IN ALL INSTANCES.
2. CONCRETE SHALL HAVE A MINIMUM COMPRESSIVE STRENGTH OF 2,500 PSI AT 28 DAYS AND SHALL HAVE FIBER MESH REINFORCEMENT.
3. BRASS IDENTIFICATION DISC AND VALVE COLLAR SHALL BE REQUIRED FOR ALL VALVES LOCATED OUTSIDE OF ROADWAY PAVEMENT.
4. IN ROADWAYS, SET ID TAG IN TOP OF CURB AND TRACER WIRE ACCESS BOX WITHIN 3 FEET OF NEAREST EDGE OF PAVEMENT OR BACK OF CURB. IN LOCATIONS WHERE THERE IS NOT A CURB, SET ID TAG IN CONCRETE PAD FOR TRACER WIRE ACCESS BOX.

general details.dwg Aug-2020



# VALVE COLLAR

DETAIL

# G-04

SHEET 1 OF 1



**City of North Port**  
**FINANCE DEPARTMENT/PURCHASING DIVISION**  
**4970 CITY HALL BLVD, STE 337**  
**NORTH PORT, FLORIDA 34287**  
Office: 941.429.7170  
Fax: 941.429.7173  
Email: [purchasing@cityofnorthport.com](mailto:purchasing@cityofnorthport.com)



**August 16, 2022**  
**ADDENDUM 2**

**TO: PROSPECTIVE BIDDERS**

**RE: RFB NO. 2023-04 Renovation of Lift Stations 29, 45 and 73 CDBG**

**DUE DATE August 24, 2022**

**City Hall, Room 337A (Bids need to be delivered to Room 337 so they can be date and time stamped on or before 2:00 PM. Bid opening will commence in Room 337A shortly thereafter)**

Bidders are hereby notified that this addendum shall be made part of the above-named bid and contract documents. The following changes to the above bid are issued to modify, and/or clarify the bid and contract documents (the deletions are as ~~striketroughs~~ and additions as underlined). These items shall have the same force and effect as the original documents, and bids to be submitted on the specified date shall conform with the additions, deletions and revisions as listed herein.

~~REMOVE 1E North Port Lift Station Renovation Wage Determination~~  
**ADD 1E North Port Lift Station Renovation Wage Determination Modification 2 Addendum 2**

Q1: Is it safe to assume that the pipes we have highlighted in yellow are not needed for this bid (suction line, drain line, and odor control pipe)?

**A1: The piping highlighted in yellow on the attachment is not required as part of this project. See attached with highlighted pipes.**

Q2: Is the HDPE offset required in the discharge riser pipe?

**A2: Yes, to be field confirmed with City Staff.**

Q3: Can this bid due date be extended for one week to allow time for questions and answers?

**A3: No, the bid date remains August 24, 2022 at 2:00 pm.**

**Firms are required to acknowledge receipt of this addendum on their proposal forms. All other terms and conditions of the original proposal and contract documents remain the same.**

*Keith Raney*

---

**Keith Raney, CPPB, CPPO**  
**Contract Administrator II**  
**Finance Department/Purchasing Division**  
**4970 City Hall Blvd.**  
**North Port, Florida 34286**  
**Tel: 941.429.7103**  
**Fax: 941.429.7173**  
**E-mail: [kraney@cityofnorthport.com](mailto:kraney@cityofnorthport.com)**

**Receipt of Addendum No. 2 shall be noted within the Bid Form in the appropriate section.  
End of Addendum No. 2**

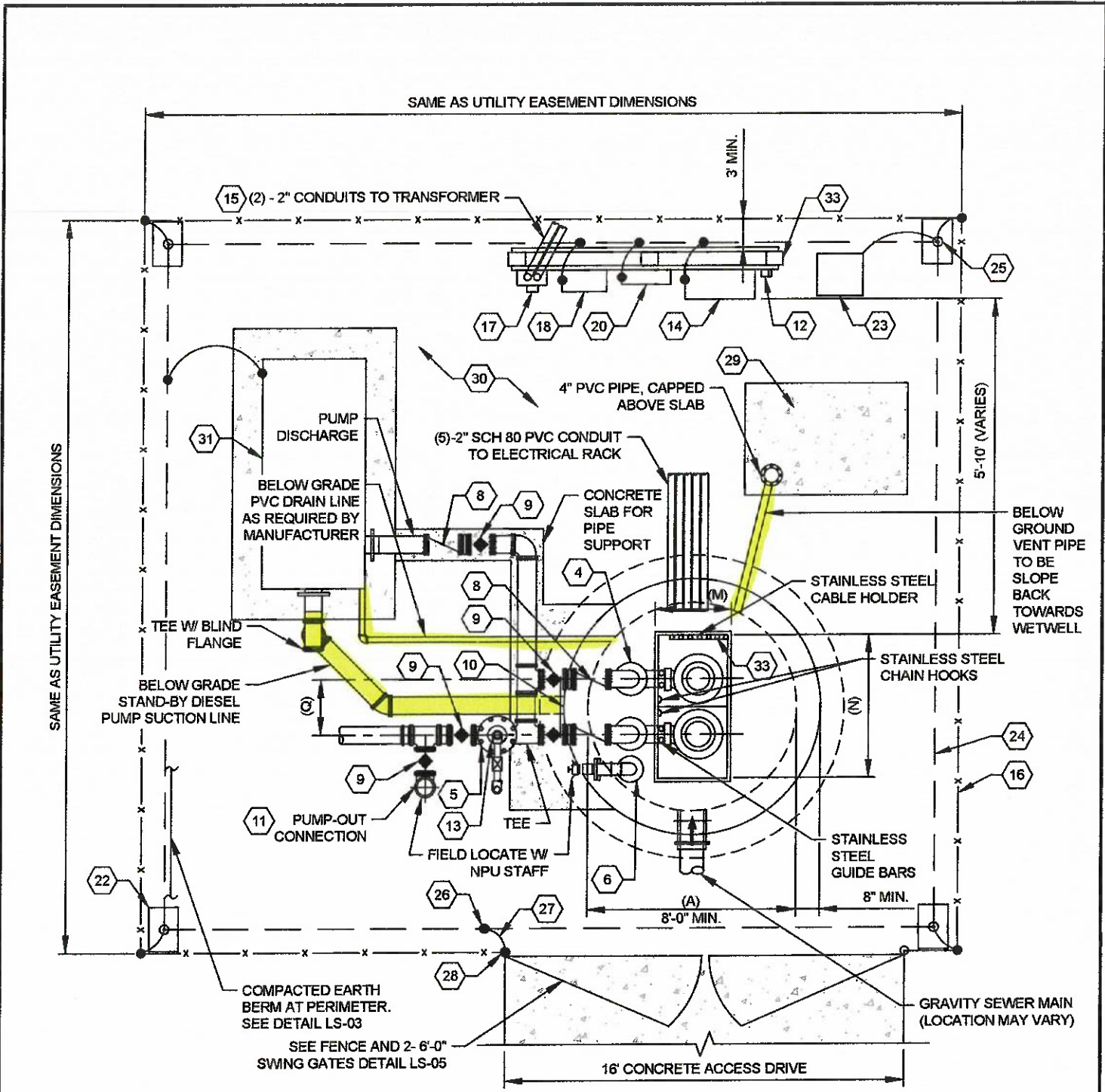

PLAN

DIMENSION TABLE

(A)	WETWELL INSIDE DIAMETER	
(M)	WETWELL HATCH OPENING	
(N)	WETWELL HATCH OPENING	
(Q)	SEPARATION OF DISCHARGE RISER PIPING	

NOTES:

1. ORIENTATION AND LOCATION OF PUMP STATION COMPONENTS MAY VARY, FIELD ADJUSTMENTS MAY BE REQUIRED.
2. SEE DETAIL LS-02 FOR SECTION VIEW.
3. CONTROL PANEL SIZE AND LOCATION MAY VARY, DEPENDING UPON STATION REQUIREMENTS. SEE SHEETS LS-06 AND LS-07.
4. ANTENNA SHALL BE ADJACENT TO CONTROL PANEL AND 3' MIN. FROM FENCE.

lift station details rev 10-2021.dwg Apr-2022



# TYPICAL LIFT STATION WITH DIESEL PUMP - PLAN

DETAIL  
**LS-01**  
SHEET 1 OF 2

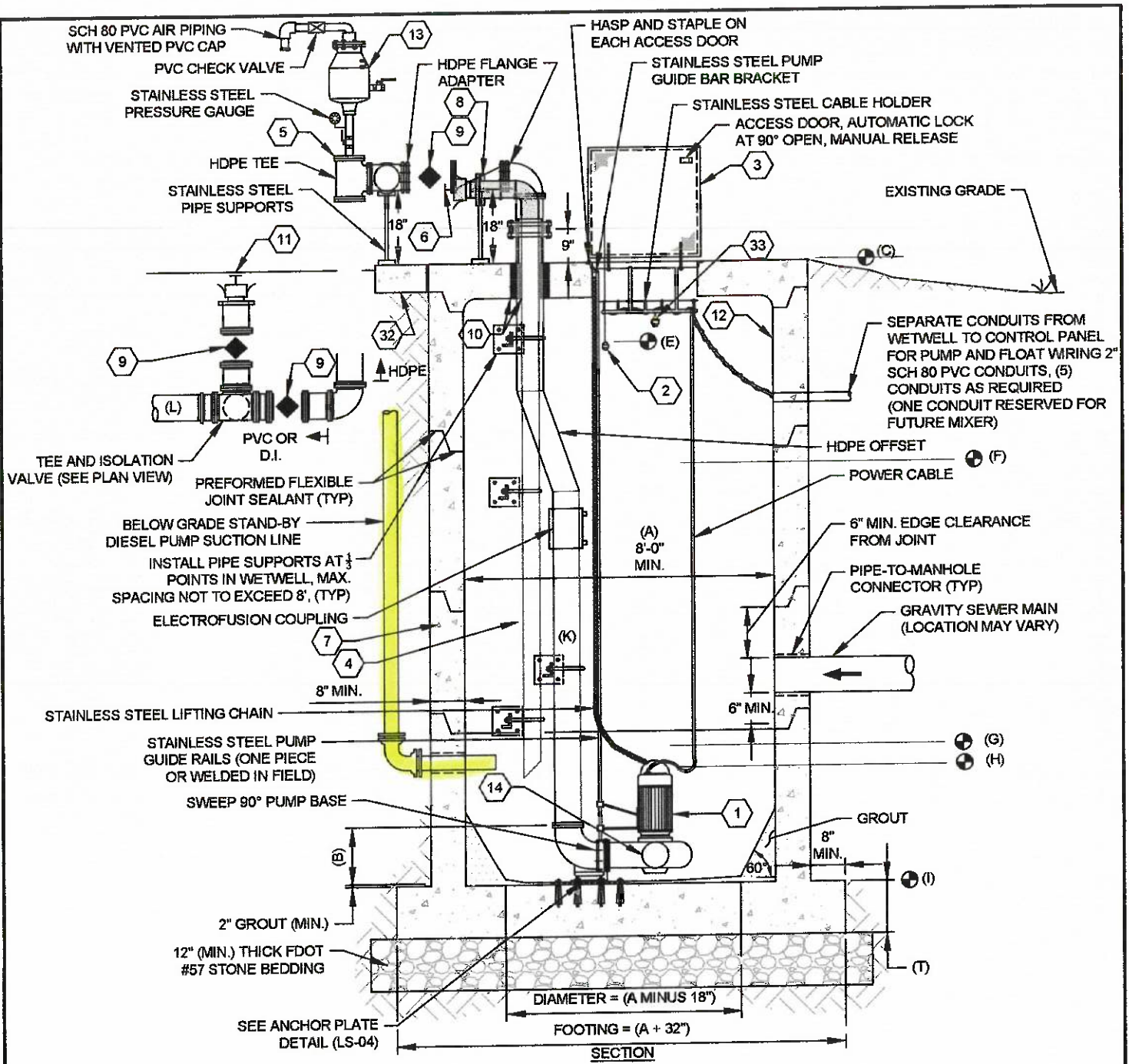

DIMENSION TABLE

(A)	WETWELL INSIDE DIAMETER	
(B)	DISTANCE FROM WETWELL FLOOR AND TOP OF DISCH. CONNECTION	
(C)	TOP OF WETWELL ELEVATION (SEE NOTE 1)	
(D)	INFLUENT PIPE INVERT ELEVATION	
(E)	HIGH WATER ALARM ELEVATION	
(F)	LAG PUMP ON ELEVATION (SEE NOTE 4)	
(G)	LEAD PUMP ON ELEVATION (SEE NOTE 4)	
(H)	ALL PUMPS OFF ELEVATION (SEE NOTE 2 & 4)	
(I)	TOP OF WETWELL FOOTING	
(K)	DIAMETER OF DISCHARGE RISER	
(L)	DIAMETER OF DISCHARGE FORCE MAIN	
(T)	THICKNESS OF FOOTING (MINIMUM 12")	

NOTES:

1. TOP OF WETWELL SHALL BE ABOVE THE FEMA 1-PERCENT-ANNUAL-CHANCE FLOOD ELEVATION.
2. SET ELEVATION H SO THAT THE MINIMUM SUBMERGENCE OF THE PUMPS IS 18", OR THE DEPTH RECOMMENDED BY THE MANUFACTURER, WHICHEVER IS GREATER.
3. ALL CONDUITS SHALL BE SEALED WITH DUCT SEAL PUTTY.
4. CONTROLLED BY RADAR LEVEL TRANSMITTER.

lift station details rev. 10-2021, dwg. Nov-2021



# TYPICAL LIFT STATION - SECTION

DETAIL

## LS-02

SHEET 1 OF 2

"General Decision Number: FL20220133 07/01/2022

Superseded General Decision Number: FL20210133

State: Florida

Construction Type: Heavy

County: Sarasota County in Florida.

HEAVY CONSTRUCTION PROJECTS (Including Sewer and Water Lines)

Note: Contracts subject to the Davis-Bacon Act are generally required to pay at least the applicable minimum wage rate required under Executive Order 14026 or Executive Order 13658. Please note that these Executive Orders apply to covered contracts entered into by the federal government that are subject to the Davis-Bacon Act itself, but do not apply to contracts subject only to the Davis-Bacon Related Acts, including those set forth at 29 CFR 5.1(a)(2)-(60).

If the contract is entered into on or after January 30, 2022, or the contract is renewed or extended (e.g., an option is exercised) on or after January 30, 2022:	. Executive Order 14026 generally applies to the contract. . The contractor must pay all covered workers at least \$15.00 per hour (or the applicable wage rate listed on this wage determination, if it is higher) for all hours spent performing on the contract in 2022.
If the contract was awarded on or between January 1, 2015 and January 29, 2022, and the contract is not renewed or extended on or after January 30, 2022:	. Executive Order 13658 generally applies to the contract. . The contractor must pay all covered workers at least \$11.25 per hour (or the applicable wage rate listed on this wage determination, if it is higher) for all hours spent performing on that contract in 2022.

The applicable Executive Order minimum wage rate will be adjusted annually. If this contract is covered by one of the Executive Orders and a classification considered necessary for performance of work on the contract does not appear on this wage determination, the contractor must still submit a conformance request.

Additional information on contractor requirements and worker protections under the Executive Orders is available at <https://www.dol.gov/agencies/whd/government-contracts>.

Modification Number	Publication Date
0	01/07/2022
1	02/25/2022
2	07/01/2022

ELEC0915-003 12/01/2021

	Rates	Fringes
ELECTRICIAN.....	\$ 31.69	41%+\$0.35

-----  
ENGI0925-010 06/01/2013

	Rates	Fringes
POWER EQUIPMENT OPERATOR:		
Crawler Cranes; Truck		
Cranes; Pile Driver		
Cranes; Rough Terrain		
Cranes; and Any Crane not		
otherwise described below...	\$ 29.61	11.50
Drill.....	\$ 29.61	11.50
Hydraulic Cranes Rated 100		
Tons or Above but Less		
Than 250 Tons; and Lattice		
Boom Cranes Less Than 150		
Tons if not described below.	\$ 30.61	11.50
Lattice Boom Cranes Rated		
at 150 Tons or Above;		
Friction Cranes of Any		
Size; Mobile Tower Cranes		
or Luffing Boom Cranes of		
Any Size; Electric Tower		
Cranes; Hydraulic Cranes		
Rated at 250 Tons or		
Above; and Any Crane		
Equipped with 300 Foot or		
More of Any Boom		
Combination.....	\$ 31.61	11.50
Oiler.....	\$ 22.91	11.50

-----  
\* IRON0397-006 07/01/2022

	Rates	Fringes
IRONWORKER, STRUCTURAL.....	\$ 32.60	16.97

-----  
LABO0517-002 05/01/2020

	Rates	Fringes
LABORER: Grade Checker.....	\$ 20.51	9.39

-----  
PAIN0088-008 06/01/2021

	Rates	Fringes
PAINTER: Brush, Roller and		
Spray.....	\$ 20.21	12.38

-----  
\* SUFL2009-172 06/24/2009

	Rates	Fringes
CARPENTER.....	\$ 14.95 **	2.92
CEMENT MASON/CONCRETE FINISHER...	\$ 14.77 **	3.50
LABORER: Common or General.....	\$ 9.50 **	1.69

LABORER: Landscape.....	\$ 7.25 **	0.00
LABORER: Pipelayer.....	\$ 13.75 **	2.06
LABORER: Power Tool Operator (Hand Held Drills/Saws, Jackhammer and Power Saws Only).....	\$ 10.63 **	2.20
OPERATOR: Asphalt Paver.....	\$ 11.59 **	0.00
OPERATOR: Backhoe Loader Combo.....	\$ 16.10	2.44
OPERATOR: Backhoe/Excavator.....	\$ 15.00	0.52
OPERATOR: Bulldozer.....	\$ 17.00	0.00
OPERATOR: Grader/Blade.....	\$ 16.00	2.84
OPERATOR: Loader.....	\$ 14.75 **	0.00
OPERATOR: Mechanic.....	\$ 14.32 **	0.00
OPERATOR: Roller.....	\$ 10.76 **	0.00
OPERATOR: Scraper.....	\$ 11.00 **	1.74
OPERATOR: Trackhoe.....	\$ 20.92	5.50
OPERATOR: Tractor.....	\$ 10.54 **	0.00
TRUCK DRIVER, Includes Dump Truck.....	\$ 11.00 **	0.00
TRUCK DRIVER: Lowboy Truck.....	\$ 12.73 **	0.00
TRUCK DRIVER: Off the Road Truck.....	\$ 12.21 **	1.97

-----

WELDERS - Receive rate prescribed for craft performing operation to which welding is incidental.

=====

\*\* Workers in this classification may be entitled to a higher minimum wage under Executive Order 14026 (\$15.00) or 13658 (\$11.25). Please see the Note at the top of the wage determination for more information.

Note: Executive Order (EO) 13706, Establishing Paid Sick Leave for Federal Contractors applies to all contracts subject to the Davis-Bacon Act for which the contract is awarded (and any solicitation was issued) on or after January 1, 2017. If this contract is covered by the EO, the contractor must provide employees with 1 hour of paid sick leave for every 30 hours they work, up to 56 hours of paid sick leave each year. Employees must be permitted to use paid sick leave for their own illness, injury or other health-related needs, including preventive care; to assist a family member (or person who is like family to the employee) who is ill, injured, or has other health-related needs, including preventive care; or for reasons resulting from, or to assist a family member (or person who is



like family to the employee) who is a victim of, domestic violence, sexual assault, or stalking. Additional information on contractor requirements and worker protections under the EO is available at <https://www.dol.gov/agencies/whd/government-contracts>.

Unlisted classifications needed for work not included within the scope of the classifications listed may be added after award only as provided in the labor standards contract clauses (29CFR 5.5 (a) (1) (ii)).

-----

The body of each wage determination lists the classification and wage rates that have been found to be prevailing for the cited type(s) of construction in the area covered by the wage determination. The classifications are listed in alphabetical order of ""identifiers"" that indicate whether the particular rate is a union rate (current union negotiated rate for local), a survey rate (weighted average rate) or a union average rate (weighted union average rate).

#### Union Rate Identifiers

A four letter classification abbreviation identifier enclosed in dotted lines beginning with characters other than ""SU"" or ""UAVG"" denotes that the union classification and rate were prevailing for that classification in the survey. Example: PLUM0198-005 07/01/2014. PLUM is an abbreviation identifier of the union which prevailed in the survey for this classification, which in this example would be Plumbers. 0198 indicates the local union number or district council number where applicable, i.e., Plumbers Local 0198. The next number, 005 in the example, is an internal number used in processing the wage determination. 07/01/2014 is the effective date of the most current negotiated rate, which in this example is July 1, 2014.

Union prevailing wage rates are updated to reflect all rate changes in the collective bargaining agreement (CBA) governing this classification and rate.

#### Survey Rate Identifiers

Classifications listed under the ""SU"" identifier indicate that no one rate prevailed for this classification in the survey and the published rate is derived by computing a weighted average rate based on all the rates reported in the survey for that classification. As this weighted average rate includes all rates reported in the survey, it may include both union and non-union rates. Example: SULA2012-007 5/13/2014. SU indicates the rates are survey rates based on a weighted average calculation of rates and are not majority rates. LA indicates the State of Louisiana. 2012 is the year of survey on which these classifications and rates are based. The next number, 007 in the example, is an internal number used in producing the wage determination. 5/13/2014 indicates the survey completion date for the classifications and rates under that identifier.

Survey wage rates are not updated and remain in effect until a new survey is conducted.

#### Union Average Rate Identifiers

Classification(s) listed under the UAVG identifier indicate that no single majority rate prevailed for those classifications; however, 100% of the data reported for the classifications was union data. EXAMPLE: UAVG-OH-0010 08/29/2014. UAVG indicates that the rate is a weighted union average rate. OH indicates the state. The next number, 0010 in the example, is an internal number used in producing the wage determination. 08/29/2014 indicates the survey completion date for the classifications and rates under that identifier.

A UAVG rate will be updated once a year, usually in January of each year, to reflect a weighted average of the current negotiated/CBA rate of the union locals from which the rate is based.

-----  
WAGE DETERMINATION APPEALS PROCESS

1.) Has there been an initial decision in the matter? This can be:

- \* an existing published wage determination
- \* a survey underlying a wage determination
- \* a Wage and Hour Division letter setting forth a position on a wage determination matter
- \* a conformance (additional classification and rate) ruling

On survey related matters, initial contact, including requests for summaries of surveys, should be with the Wage and Hour National Office because National Office has responsibility for the Davis-Bacon survey program. If the response from this initial contact is not satisfactory, then the process described in 2.) and 3.) should be followed.

With regard to any other matter not yet ripe for the formal process described here, initial contact should be with the Branch of Construction Wage Determinations. Write to:

Branch of Construction Wage Determinations  
Wage and Hour Division  
U.S. Department of Labor  
200 Constitution Avenue, N.W.  
Washington, DC 20210

2.) If the answer to the question in 1.) is yes, then an interested party (those affected by the action) can request review and reconsideration from the Wage and Hour Administrator (See 29 CFR Part 1.8 and 29 CFR Part 7). Write to:

Wage and Hour Administrator  
U.S. Department of Labor  
200 Constitution Avenue, N.W.  
Washington, DC 20210

The request should be accompanied by a full statement of the interested party's position and by any information (wage payment data, project description, area practice material, etc.) that the requestor considers relevant to the issue.

3.) If the decision of the Administrator is not favorable, an interested party may appeal directly to the Administrative

Review Board (formerly the Wage Appeals Board). Write to:

Administrative Review Board  
U.S. Department of Labor  
200 Constitution Avenue, N.W.  
Washington, DC 20210

4.) All decisions by the Administrative Review Board are final.

=====

END OF GENERAL DECISIO"